

# Internet of Things Based Process Model for Smart Parking System

Amjaad Alsalamah, Liyakathunsia Syed

**Abstract**—Transportation is an essential need for many people to go to their work, school, and home. In particular, the main common method inside many cities is to drive the car. Driving a car can be an easy job to reach the destination and load all stuff in a reasonable time. However, deciding to find a parking lot for a car can take a long time using the traditional system that can issue a paper ticket for each customer. The old system cannot guarantee a parking lot for all customers. Also, payment methods are not always available, and many customers struggled to find their car among a numerous number of cars. As a result, this research focuses on providing an online smart parking system in order to save time and budget. This system provides a flexible management system for both parking owner and customers by receiving all request via the online system and it gets an accurate result for all available parking and its location.

**Keywords**—Smart parking system, IoT, tracking system, process model, cost, time.

## I. INTRODUCTION

FINDING a spot in crowded places such as malls or near from the school or university can be a tough job. However, many people around the world argue that parking system should be resolved either practically or technically to save time and cost at the same time. In fact, the issue is raised globally because during the rush hour drivers always waste their times just to check the available parking space as in cases that might take them more than an hour in busy cities like New York, Paris, and London. Therefore, using Internet of Things (IoT) mechanisms and network techniques can be an ideal method to make an effective system that can reduce traffic and get the benefit of each space without disturbing other drivers or losing money [5].

### A. Problem Identification

Although some countries followed the traditional way of taking the paper ticket from the driver, there are still drawbacks for this practice.

In particular, when the driver got his/her ticket in multilevel parking slots especially in malls, he/she might not find any empty slot or he/she needs to turn many times just to check if he/she misses slot. In fact, as a personal experience particularly in Bahrain, we tried to park our car during weekend day and each level had an electronic sign showing the available number of slots, so this helped us to reach the least crowded level. This example illustrates the need for

smart parking system in order to know the exact number of available parking slots and control the traffic at the same time. On the other hand, issuing a ticket cannot guarantee the security to the car owner as there are some cases when thieves exploited the ticket system and stole the car without any identification or authorization [6]. Therefore, smart parking system can be beneficial for the car owner to find an empty slot, save the time, and eliminate car thief. In addition, it will help management in parking system to track all cars and identify any suspicious activity. Also, this system can provide electronic transactions like online payment and email notification.

## II. LITERATURE REVIEW

There are many approaches to implement smart parking system, and in this paper, we will review some ideas and related techniques. In particular, each technique can maintain similar methodologies such as finding parking lots to the driver, amending parking status, paying the parking fee, and saving whole data in the central database. However, the main difference between those systems is the type of technology and mechanism [1].

According to Souissi [4], the smart parking system can be achieved using wireless network. In fact, he supported his solution by suggesting that we can use sensor nodes in each parking slot and advised that the communication in the system can be received and forwarded through the Wireless Network. For example, if one slot becomes available, it will directly update its status and pass the information to the neighbor node and keep spreading the updated status until reach the main system [2]. The system will accept the status which comes as a binary result either 0 or 1 in order to update slots database [4].

Hartono and Hutabarat [3] proposed another solution by implementing smart parking system using E-commerce Solutions to Parking Space Optimization (ESPSO) along with Bluetooth. For instance, when the car enters parking zone, the system will scan the vehicle's license plate image and save into the central data and link all drivers' information with their cars. Moreover, they suggested utilization of the Bluetooth service by sending updates parking messages through mobile devices and they use it as the payment method at the same time [3].

These are some proposed solutions to apply smart parking system and in order to choose the perfect approach, we should decide the budget, system requirement, system policies and the infrastructure plan before initiating any project.

Amjaad Alsalamah (student) is with the Department of Computer Science, Prince Sultan University, Riyadh (e-mail: amjaad.alsalamah@gmail.com).

Liyakathunsia Syed, Assistant Professor, is with the Prince Sultan University, Riyadh (e-mail:lsyed@psu.edu.sa).

### III. BPM LIFE CYCLE

The BPM life cycle is clarifying all BPM phases in order to accomplish the project by linking all related procedures of smart parking system as following phases:

1. Design
2. Modeling
3. Execution
4. Monitoring
5. Optimization

In the first phase, the identification of all problems should be established by collecting inputs and define all potential requirements such as estimated time and cost. Furthermore, we need to begin the modeling phase with an enhanced parking system to simulate all required features. This allows us to study the project scope in a safe environment and to observe all expected output and eliminate any errors before releasing to the production. Consequently, after discovering all possibilities in modeling, the execution phase starts with determining all required resources including hardware, software, and human interaction. In particular, the smart parking system will enable to work remotely and run all services as an online platform. In addition, monitoring the system is required to maintain all functionalities. Measuring the performance should be checked repeatedly by confirming that the result is accurate, e.g. checking the number of the available parking lot. Finally, we need to review all functions and identify any weaknesses in the optimizing phase. This helps to improve the system and its features and it should be an ongoing process.

### IV. REQUIREMENT COLLECTION

The survey was created for data collection purpose to study and analyze the important requirement. The conducted questions were mainly focused on how users find the functionality of the current parking system in Saudi Arabia. The result was showing that 60% of participants think that the mechanism is time-consuming. Also, 65% of people spend more than 30 minutes to find an available parking spot. In addition, 70% responses said that there is no control to tell if the parking is full or not. In addition, the survey asked about payment method, and the results were varying from cash or credit card bit, but there is no response for online payment. All these feedbacks about the current parking system help to find all required functions in order to improve the service with a new smart parking system.

#### A. Functional Requirements

To use IOT for smart parking system, we can use cloud-based service to sync all data directly into the cloud. Thus, we need to choose one of cloud service providers to save all data related to smart parking system including slots number and area. Furthermore, the centralized server is the best approach to manage smart parking system and provide important information like the availability of parking. Also, getting information about available slot can be achieved by adding sensors to track all available slots. In addition, all these data should be transported through secured network, and

encryption should be provided to eliminate any unauthorized access or leakage of data. This smart parking should also obtain an access to databases that store information about available parking slots. Also, the camera is needed to capture images for the parking area and connect it to the network. Moreover, the navigation system is essential to navigate the user to parking slots. Also, both the administrator and user need to have devices such as smartphones with valid authentication to connect to the system and get all data [5].

The scope of functional requirements in this study as following:

- Request parking spot through online application
- Connect all requests to smart parking system database
- Select the potentially available parking to reserve
- Get estimated time for the nearest available parking spot
- Book parking spot through the online system
- Make payment using different methods including cash and online payment
- Check payment and get the validation result
- Show an error message if the payment is failed
- Confirm booking for parking spot with details

#### B. Non-Functional Requirements

On the other hand, smart parking system should make sure that the system is secured and only authenticated user will be able to access. Also, for confidentiality, all credential information including username, password, payment method should be protected. Moreover, for recoverability and availability the system should be available all time and whenever the system is down, the backup should be ready to serve all users with the same capabilities. In addition, maintenance should be provided in the case of any software or hardware failures. Therefore, it is important to keep the performance stable all time and get real-time data to display the result of parking slots. Meanwhile, the system should ensure the integrity of payment information by using a suitable hashing method to avoid any data leakage. Likewise, these payment data should be encrypted to protect the privacy and eliminate any unauthorized access.

### V. PERFORMANCE MEASURE

In our proposed approach for smart parking system, enhanced functions provide quality service compared to the old system including different fields such as time and cost. The proposed system works as online service to become available all time and remote. As a result, this system decreases the time that each customer spends to find an available parking slot. In addition, the system will lower the traffic by guiding all customers to the potential spot without waste any time. In fact, the system will send all parking details including location and direction. This saves a huge amount of time from hours to minutes. The proposed system will provide all payment options to speed up the process and reduce the waiting time to pay cash manually. The system will get a confirmation message once the payment is received and verified. The smart parking system will manage all parking on time and diminish the cost in general (see Fig. 2).

VI. PROPOSED SMART CAR PARKING SYSTEM

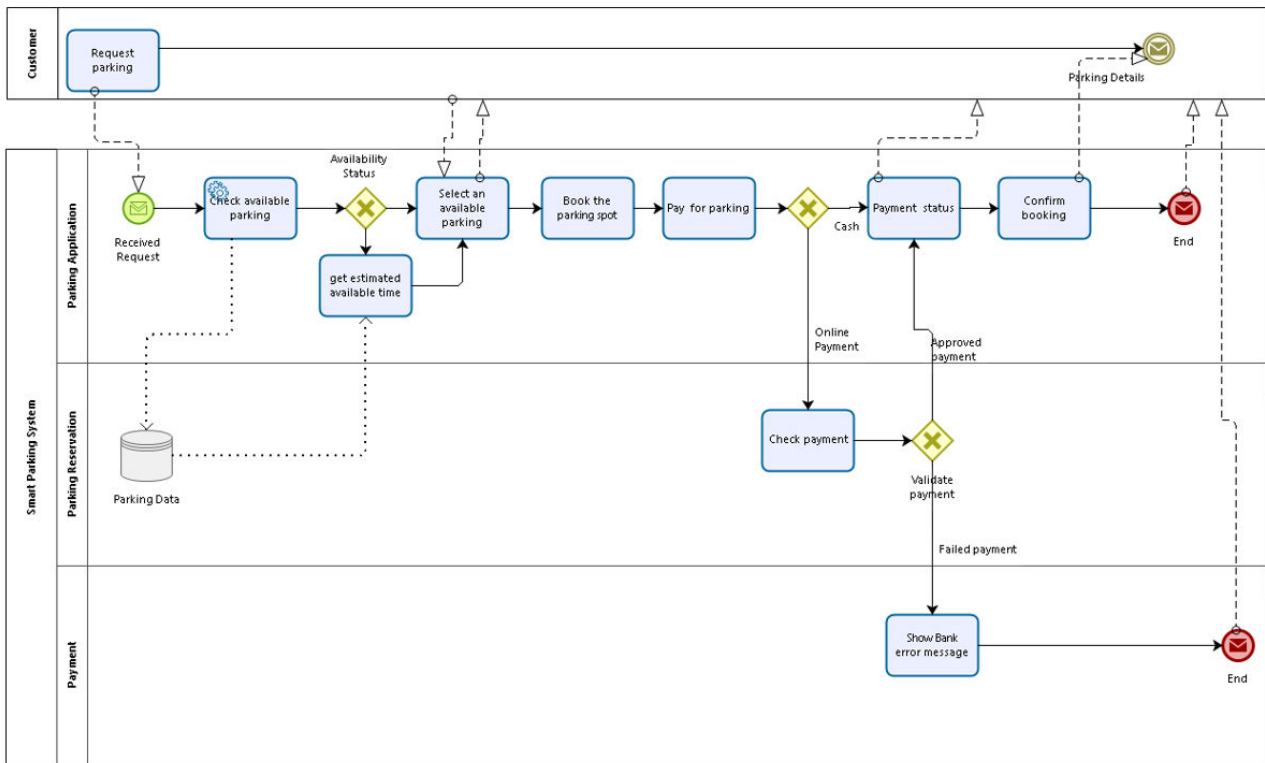

Fig. 1 Process model for smart car parking system

A	B	C	D	E	F	G	H	I	J	K	L	M	N
Name	Type	Instances completed	Instances started	Min. time (m)	Max. time (m)	Avg. time (m)	Total time (m)	Mi n.	Max. time	Avg. time	Standard deviation	Total time	Total fixed cost
Check available parking	Task	87	92	5	5	5	435	0	0	0	0	0	920
get estimated available time	Task	44	46	5	5	5	220	0	0	0	0	0	460
Select an available parking	Task	82	85	2	2	2	164	0	0	0	0	0	850
Book the parking spot	Task	79	82	5	5	5	395	0	0	0	0	0	2050
Pay for parking	Task	72	79	5	5	5	360	0	0	0	0	0	1975
Check payment	Task	25	27	5	5	5	125	0	0	0	0	0	1350
Payment status	Task	53	56	5	5	5	265	0	0	0	0	0	1400
Confirm booking	Task	48	53	5	5	5	240	0	0	0	0	0	2650
Show Bank error message	Task	14	14	5	5	5	70	0	0	0	0	0	350
Smart Parking System	Process	62	92	27	37	30.5483871	2274					0	12005
Received Request	Start event	92											
Availability Status	Gateway	87	87										
ExclusiveGateway	Gateway	72	72										
Validate payment	Gateway	25	25										
End	End event	48											
End	End event	14											

Fig. 2 Simulation results for smart car parking system

VII. CONCLUSION

This study highlights the current parking system weaknesses and collects the feedback from the current user. The results were showing a lack of capabilities to handle the traffic and control parking system. Moreover, the flexibility was not much present in the system as only limited payment

methods were available. In fact, the online payment was rarely used. In addition, all complaints were mainly about the difficulty of finding an available parking spot in a limited period of time. As a result, the new smart parking system is designed to provide an accurate result to find the available parking spot through the online application. In fact, the whole

process can be done remotely by checking and selecting the parking spot. Furthermore, any customer can choose any type of payment methods to pay and reserve the parking spot.

In fact, the system allows the user to enter the online payment details and verify it through banking gateway in order to get the payment approval. Therefore, this application provides the flexibility, on time update and online process to control all parking spots effectively and manage all traffic within a reasonable time. This application always has scope for improvement based on the feedback and customer interaction. The model can further be enhanced to the service accordingly.

#### REFERENCES

- [1] A. Amit. "Review on Automatic Car Parking Indicator System." *International Journal on Recent and Innovation Trends in Computing and Communication IJRITCC* 3, no. 4 (2015): 2158-161. doi:10.17762/ijritcc2321-8169.150485.
- [2] Asín, Alicia, and David Gascón. "Smart Parking Sensor Platform Enables City Motorists save Time and Fuel." May 27, 2011. [http://www.libelium.com/smart\\_parking/](http://www.libelium.com/smart_parking/). Accessed on 24/12/2016.
- [3] Hartono, R. W. Tri, and Mervin T. Hutabarat. "Product Service System: Design of E-commerce Solutions to Parking Space Optimization Using Bluetooth Technology." *Proceedings of the 2011 International Conference on Electrical Engineering and Informatics*, 2011. doi:10.1109/iceei.2011.6021727.
- [4] Souissi, Rachid, Omar Cheikhrouhou, Ines Kammoun, and Mohamed Abid. "A Parking Management System Using Wireless Sensor Networks." *ICM 2011 Proceeding*, 2011. doi:10.1109/icm.2011.6177403.
- [5] S R. Basavaraju. "Automatic Smart Parking System Using Internet O F Things (IOT)." *International Journal of Scientific and Research Publications* 5, no. 12 (2015).
- [6] Wang, Hongwei, and Wenbo He. "A Reservation-based Smart Parking System." *2011 IEEE Conference on Computer Communications Workshops (INFOCOM WKSHPS)*, 2011. doi:10.1109/infcomw.2011.5928901.