

Solar Tracking System Using a Refrigerant as Working Medium for Solar Energy Conversion

S. Sendhil Kumar, S. N. Vijayan

Abstract—Utilization of solar energy can be found in various domestic and industrial applications. The performance of any solar collector is largely affected by various parameters such as glazing, absorber plate, top covers, and heating pipes. Technology improvements have brought us another method for conversion of solar energy to direct electricity using solar photovoltaic system. Utilization and extraction of solar energy is the biggest problem in these conversion methods. This paper aims to overcome these problems and take the advantages of available energy from solar by maximizing the utilization through solar tracking system using a refrigerant as a working medium. The use of this tracking system can help increase the efficiency of conversion devices by maximum utilization of solar energy. The dual axis tracking system gives maximum energy output compared to single axis tracking system.

Keywords—Refrigerant, solar collector, solar energy, solar panel, solar tracking.

I. INTRODUCTION

CURRENTLY, 80% of the world energy is produced from the fossil fuels imposing a real threat to the environment, apparent mainly through global warming and acidification of water cycle [3], [25]. The distribution of fossil fuels around the world is uneven. Most of the energy is extracted from the middle-east oil reserves. Increase in usage of energy occurs due to enhancement of their standard of living thereby increasing the risks. These results in the reduction of energy storage which needs to find an alternative solution. Because of the maximum energy requirement, consequently there is increase in the rate of combustion of oil and coal. Location of alternatives is absolutely necessary considering these facts, as the available oil is running out fast.

Renewable energy is one of the most promising alternative solutions to the above problems. Renewable energy sources are even larger than the traditional fossil fuels and in theory, can easily supply the world's energy needs. The solar power which falls on the earth is around 89%. While it is not possible to capture all or even most of this energy, capturing even less than 0.02% would be enough to meet the current energy needs. [24]

II. LITERATURE REVIEW

Solar collectors are commonly used for active conversion of solar energy to heat. In the recent years, solar energy is directly converted into electrical energy using solar

photovoltaic system. In order to overcome the drawback of conventional solar collectors in winter, that is, its unavailability due to low water temperature or even freezing, a new design of solar collectors is presented. This is based on combination of a novel compound curved surface concentrator and an aluminum concentric solar receiver contained in a double-skin glass evacuated tube. The average ambient temperature is below 0 °C, the water temperature can be heated up to 80 °C with a daily average efficiency of about 50% [1]. The efficiency of a flat plate collector is found to increase with increase in ambient temperature with a single glass cover [2]. Performance of coated solar flat plate collector has been analyzed by introducing a new heating system at a low cost. Copper, stainless steel and aluminium were used as header and riser tubes for fabricating the equipment to analyse the performance. The output illustrates that copper, aluminium and stainless exhibit the same performance although cost of stainless tube with epoxy-polyether and aluminium with copper oxide is lesser than that of the copper tube [3]. Investigations have been carried out on the cost minimization of solar flat plate collector using ceramic coated panel, insulation, maintenance, durability and its life considerations [4]. The effect of glass thickness of flat plate solar collectors for fruits drying has been determined using a different glass thickness with minimum of 4 mm thickness. This shows the change in glass thickness resulting in variation of collector efficiency with 4 mm glass thick giving the best efficiency of 35.4% compared to 27.8% for 6 mm glass thick [5].

Thermal efficiency of the flat plate solar air heater has been analyzed in single and double pass smooth plate solar air collectors with and without porous media [6]. The performance of the variations of top loss heat transfer coefficient with absorber plate emission and air gap spacing between the absorber plate and the cover plate has been evaluated [7]. Productivity of the flat plate solar collector system has been estimated by using the present methods of average monthly and annual productivity [8]. The performance of the flat plate collector with different geometric absorber configurations has been analyzed. Variations in efficiency were found in the given collectors with their given parameters, as also variation in cost, area, and storage outlet temperature. A considerable scope was also found to reduce to the collector area, cost and minimizing the number of tubes and its result at same outlet temperature by changing the geometric shape of flat plate collector [9]. Performance characteristic of the solar flat plate collector with three different selective surface coatings was analyzed. The performance of solar thermal absorber can be improved by

Sendhil Kumar S. is with the INFO Institute of Engineering, Coimbatore, India (e-mail: ssk333c@yahoo.co.in).

Vijayan S.N is with the Karpagam Institute of Technology, Coimbatore, India (e-mail: s.n.vijayan@gmail.com).

change of absorber materials and coating thickness [10]. The efficiency and performance of flat plate collector can be improved by increasing the transmissivity of the glazing using highly transmissive polymer films or low iron glass [11].

An efficient and a low power programmable system on chip based sun tracker device has been designed [12]. Solar energy based street lights with auto tracking system to increase the conversion efficiency of the solar power generation was analyzed [13]. Design and implementation of energy efficient continuous solar tracking system from a normal mechanical single axis to a hybrid dual axis was discussed [14]. A dual-axis solar tracking controller for increasing the performance of the solar panel has been fabricated and installed [15]. An automatic solar-tracking mechanism using an embedded system design with minimum cost and reliable structure has been designed and implemented [16]. The solar cell array system with the sun tracking system has been analyzed to get maximum output from the available solar energy [17]. The efficiencies of single-axis tracking system and dual-axis tracking system are compared with fixed mount solar system [18]. The performance of a solar tracking system driven by PIC 18F452 micro controller has been analyzed [19]. A micro controller based solar panel tracking system has been developed for increasing the volume of power generated by the solar panel as the sun traverses across the sky with 8051 micro controller to control the movement of the solar panel [20]. Three dimensional hemispherical rotations for tracking the sun's movement and for improving the overall electricity generation with the help of Atmel 8051 micro controller has been performed [21]. A prototype of micro controller based automatic solar tracking system have been constructed with Light dependent resistors for tracking the sun under both normal and bad weather conditions [22]. A single axis solar tracker system for PV conversion panels have been designed for proper orienting of the PV panel in accordance with the real position of the sun for maximize the output of solar energy produced by the PV panel for sufficient values of light signal intensity [23].

III. PROBLEM IDENTIFICATION

Electricity plays a key role in our day to day lives. But the energy sources of electric power have been used literally and hence researchers were compelled to find an alternate source of power which leads to utilization of the heat energy from solar. Solar energy is unlimited, pollutant free and can be converted into electricity using employing an alternative energy conversion device. These panels and solar collectors are utilized in an solar tracking system. Efficiency can be increased if the solar panel is made to rotate instead of fixed one. In a single axis system, the panel is moved in an east to west direction with respect to the sun and has better efficiency than panels in the fixed direction. The efficiency can be improved still if the tracking is in the dual axis mode.

IV. NEED FOR A SOLUTION

This study intends in tracking the solar panel or solar collector along the direction of the sun for increasing the maximum utilization of solar energy. The unique feature of this system is that, instead of taking the earth as its reference, it takes the sun as the guiding source. Sunlight has two components, viz., the "direct beam" that carries about 90% of the solar energy, and the "diffuse sunlight" that carries the remainder. As the majority of the energy is in the direct beam, maximizing collection requires the sunlight to fall straight onto the panels or collectors as long as possible hence the need of tracker is necessary. The solar panel is tracked by using a refrigerant. Currently, tracking is primarily done by using electric motor, sensors, micro controllers, PLC and manually by many other methods where some input is given to it. In this paper, an approach is taken for using a refrigerant like R744 (CO₂), FREON 12, Ammonia, FREON 22, and FREON 135 as a source. Based on the pressure variation of the refrigerants, an automatic mechanism is designed and fabricated. It can achieve the maximum solar power utilization by increasing the efficiency of the device.

V. FLAT PLATE COLLECTOR

A typical flat-plate collector made up of an absorber placed in an insulated box together covered with transparent sheets is shown in Fig. 1. The absorber is usually made up of a metal sheet of high thermal conductivity such as copper or aluminum, with integrated or attached tubes. Its surface is coated with a special selective material for receiving highest radiant energy absorption and minimizing the release of radiant energy. The purpose of insulation for the box is to reduce heat losses in the collector.



Fig. 1 Flat Plate Collector

The main components associated with flat plate collector, namely, absorber plate, top covers, heating pipes, heat insulating backing and heat-transport fluid are shown in Fig. 2. The absorber plate is selectively coated for ensuring high absorptive capability. It receives heat by solar radiation and the heat is transferred by conduction to the flowing liquid through the heating pipes. The fluid flow through the collector pipes is by natural or by forced circulation. Usually, absorbers of all flat plate collectors are fabricated using straight copper

or aluminum sheets to prevent the heat collection surface transfer area.

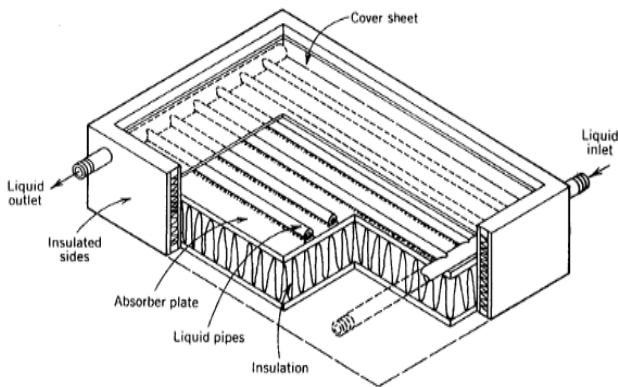

Fig. 2 Cross-section of a typical liquid flat plate collector

VI. SOLAR PANEL

A solar cell, or photovoltaic cell, is an electrical device that converts light energy directly into electricity by the photovoltaic effect. Solar modules use light energy (photons) from the sun to generate electricity through the photovoltaic effect. The majority of modules use water-based crystalline silicon cells or thin-film cells based on cadmium telluride or silicon. The structural (load carrying) member of a module can either be the top layer or the back layer. Cells must be protected from mechanical damage and moisture. Most solar modules are rigid, but semi-flexible ones are available, based on thin-film cells.

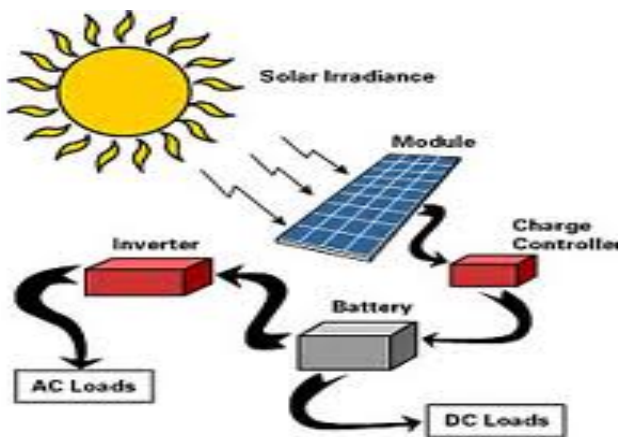

Fig. 3 Direct solar energy conversion

TABLE I
COMPARISON OF POSSIBLE SOLUTIONS

Type of Tracking	Microcontroller and stepper motor	PLC unit	Refrigerant
Material	Microcontroller, Drive trackers	PLC unit, sensors	Freon
Man power	Less	Less	Not needed
Cost	High	High	Less
Pollution	No	No	No
Production process	Need continuous checking	Need continuous changes	Easy

Fig. 3 explains the conversion technology of solar energy into direct electricity with the help of the solar photovoltaic device. The components of PV systems are solar module, battery and inverter.

VII. TYPES OF TRACKING SYSTEM

A. Using Microcontroller and Stepper Motor

This tracker is designed with solar panels, LDR, ADC, Microcontroller, Stepper Motor and its driving circuit. LDRs are fixed in the solar panel at two different locations. The variation of resistance due to the fall of sunlight is converted to digital signal. Converted digital signal is given as the input to the microcontroller, which receives the two digital signals from the ADC and compares them. When there is a difference in the LDR voltage levels, the microcontroller program drives the stepper motor towards normal incidence of sunlight. Stepper motors are used for driving the Solar Tracker to the best angle.

B. Using PLC

PLC (Programmable Logic Controller) is used as a device for controlling the output of the motor. When the sun is not visible during a short period due to cloudy weather, the PLC is set with a program which can stop the rotation of motor. Once the sensor detects the availability of the sun, the motor gets reactivated to continue its next cycle. The tracking is done by a programmed Time-Delayed movement of the panel throughout the day. The delay is set in the PLC and the step-by-step movement is achieved by a proximity sensor thereby providing the feedback to the PLC. The output of the panel which is DC Voltage is measured with a multi meter.

C. Using Refrigerant as Working Medium

The main components are a solar panel, refrigerant holders, copper tubes and a double acting cylinder. The solar panel is mounted on the shaft fitted in two columns with bearings. The lever is connected to the piston of the double acting cylinder and one end of the shaft. The holders are filled with a liquid refrigerant and the tubes are connected to the double acting cylinder. When the radiation or sun ray on one side is greater than other side, a difference in pressure is created in the double acting cylinder through the vaporization of the liquid refrigerant (latent heat). This pressure moves the piston of the double acting cylinder, which rotates the solar panel along the direction of the sun with the help of a link. This automatic mechanism helps achieving maximum solar power utilization.

VIII. CONSTRAINTS AND RESTRICTIONS ON THE SOLUTION

Comparison of all the above possible solutions of the tracking system has been made based on literature survey dealing with the performance over the tracking system with parameters such as material, manpower used, cost, pollution and production processes which is tabulated in Table I. Based on the constraints and restrictions on the various type of solution cited in Table I, tracking is found to be better through the solar panel tracking using refrigerant as working medium.

As the tracking focusses on solar intensity, tracking of solar panel will be an energy efficient one.

IX. COMPONENTS USED

The various components needed for the solar tracking system using a refrigerant as working medium are solar panel, double acting cylinder, refrigerants, refrigerant holders, bearings, copper tubes and shaft used for supporting the panel and the collector.

X.CONSTRUCTION

Two columns are provided along with the fixed base. These columns are placed with some space between them. The shaft is placed in the columns along with the bearings which provide easy movement along the required direction for the shaft. The solar panel is clamped along with the shaft with the help of clamps and bolts in such a way that the panel must rotate along with the shaft. A double acting cylinder which is mounted towards one end of the shaft is provided with a link. The link connects the shaft along with the double acting cylinder. As the piston slides upwards, solar panel turns towards west direction. When the piston moves downwards, the panel rotates towards east direction. Refrigerant holders are placed on the opposite sides of the panel along the east and west direction. Shades are provided across it on one side such that it stops the sun's rays falling on it when the sun is in the opposite direction. Copper tubes are used here to connect the double acting cylinder and the refrigerant holders acting as a passage for the movement of the expanded refrigerant from the holders to the cylinder. The expansion which occurs in the refrigerants causes up and down movements. The layout and model of this system is shown in Figs. 4 and 5.

XI. WORKING PRINCIPLE

A. Position: 1

The intensity of the sun's rays is more in the east in the mornings. The holder on the east side has a liquid refrigerant which gets heated up due to the sun's rays. The expansion of the refrigerant is therefore more in the east side of the cylinder than in the west side. The pressure in the bottom position of the double acting cylinder is more and the piston attached to the cylinder tends to move upwards, the eccentric arm tilts the panel along the east side. The intensity of the sun's rays fall perpendicular to the solar panel which is shown in Fig. 6.

B. Position: 2

The sun's position is at the center at noon, due to which there will be equal intensity of sun's rays on both the holders. This causes equal expansion of the refrigerant on both sides in the cylinder. At this moment, the panel remains horizontally so that the intensity of sun's rays falls directly on it. This position is shown in Fig. 7. This is the time when larger power can be generated since the intensity is high and the distance between the sun and the panel is also high. So, the output can reach peak value in the noon time.

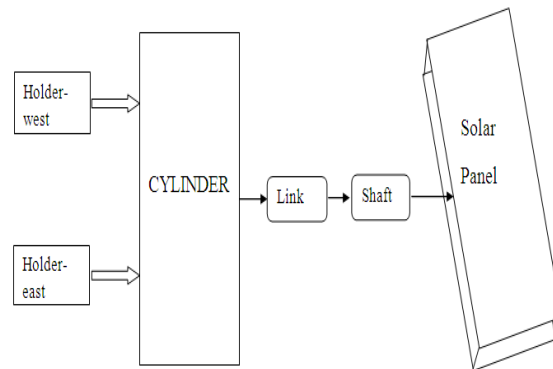

Fig. 4 Schematic layout of Solar tracking system

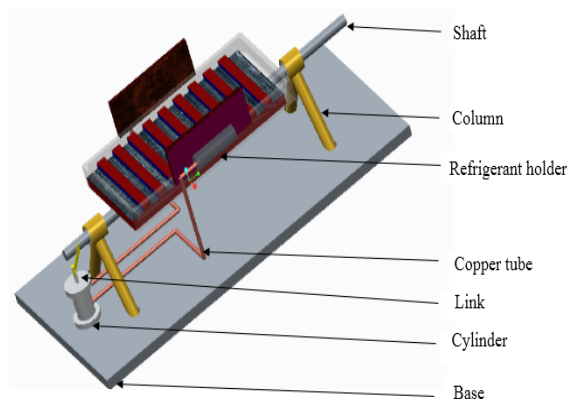

Fig. 5 Model of Solar Tracking System with Refrigerant

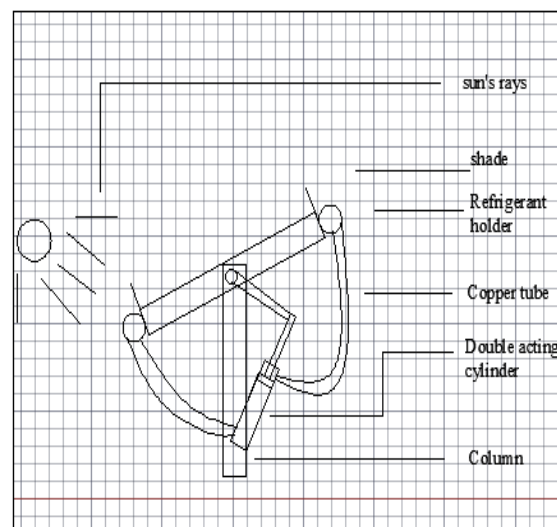

Fig. 6 Position 1

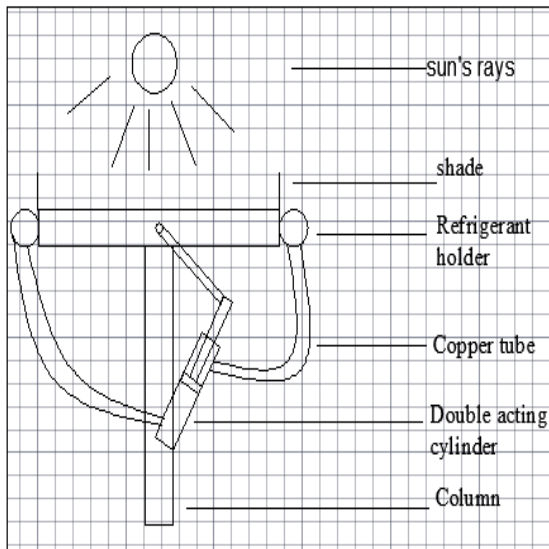

Fig. 7 Position 2

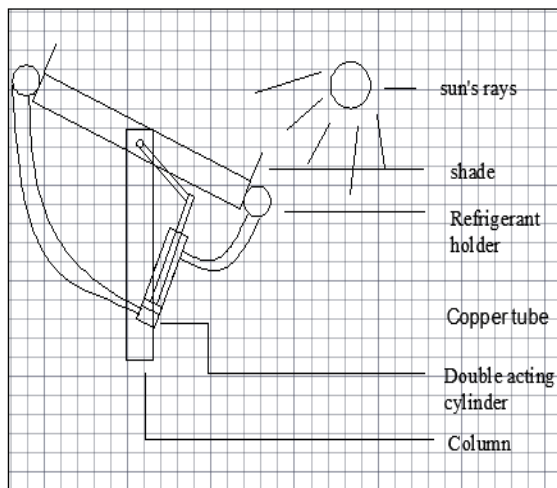

Fig. 8 Position 3

C. Position: 3

The intensity of the sun's rays is more on the west side during the evening. The holder on the west side having a liquid refrigerant gets heated up causing more expansion on the west side of the cylinder. So, the pressure in the top position of the double acting cylinder causes a downward movement in the piston attached to the cylinder. The eccentric arm of the cylinder tilts the shaft towards the west. The sun's rays fall perpendicular to the solar panel this position is shown in Fig. 8.

XII. DISCUSSION

The solar tracking system with a refrigerant as the working medium can be used for maximizing the extraction and conversion efficiency of the devices. The intensity of the light energy changes during the day. In the first position of the cylinder, the liquid refrigerant gets heated up on the eastern

side more than on the western side. This triggers expansion of the refrigerant more on the eastern side, the pressure in the bottom position gets larger and the piston attached to the cylinder moves upwards. In the second position, the sun's position is at the centre, above our heads. So, the intensity of heat of the sun's rays is equal on both the holders, with equal expansion on both sides. The extraction of the light energy is very high in this position and produced power will be substantial. In the third position, the intensity of the sun's rays is more on the western side. The holder on the west with the liquid refrigerant gets heated up on the west more than in the east with the expansion too being more.

XIII. CONCLUSION

The conclusion from the study is that the performance of solar energy conversion system such as solar collector and solar PV system varies with respect to the direction of sunlight falling on its absorbing area. Without tracking the movements of sun, the utilization and conversion efficiency of conversion devices are very minimum in a fixed position due to continuous movement. The need to track the sun's movement for extracting the solar energy and maximize the utilization also increases the conversion efficiency of the devices. In this study the tracking system is used with a refrigerant as the working medium to rotate the device with respect to sun's rotation. Energy production of output power increases as a result of the continuous extraction and minimum utilization of light. While the conversion efficiency increases simultaneously. Use of double axis solar tracking system in the place of a single system can increase the overall efficiency.

REFERENCES

- [1] Hongfei Zheng, GangWu, Jing Dai, and YanyanMa, "Design and Testing of a Shell-Encapsulated Solar Collector with the Compound Surface Concentrators", International Journal of Photoenergy, Article ID 130187.
- [2] Eklabya Gupta, Shailendra kumar bohida, Prakash kumar sen, "Study on a Flat Plate Solar Collector", International Journal of Advance Research in Science and Engineering, Vol. No.4, Special Issue (01), March 2015.
- [3] S. Rajasekaran, M. Chandrasekar, T. Senthil Kumar, "Performance Analysis of Coated Solar Flat Plate Collector", International Conference on Energy Efficient Technologies for Automobiles, JCHPS Special Issue 6: March 2015, PP. 240 – 243.
- [4] Ayyappan Rajagopal, Vijayan Gopalsamy, R.Karunakaran, Naveen Kumar Rajendran, Muniraj Gowran, "Experimental Investigation of Solar Flat Plate Collector Using Ceramic Coated Panel", IOSR Journal of Mechanical and Civil Engineering, PP 75-79.
- [5] Ramadhani B, Rwaichi. J.A Minja and Karoli N. Njau, "Effect of Glass Thickness on Performance of Flat Plate Solar Collectors for Fruits Drying", Journal of Energy, Volume 2014, Article ID 247287.
- [6] Dr. Bhupendra Gupta, Jitendra Kumar Waiker, Gopal Prasad Manikpuri, Brahman Singh Bhalavi, "Experimental Analysis of Single and Double Pass Smooth Plate Solar Air Collector with and without Porous Media", American Journal of Engineering Research, Volume-02, Issue 12, pp-144-149.
- [7] Dara J.E/Miaeng, Ikebuda K.O/Miaeng, Ubani N.O/Miaeng, Chinwuko C.E/Miaeng, Ubachukwu O. A/Miaeng, "Evaluation of a Passive Flat-Plate Solar Collector", International Journal of Advancements in Research & Technology, Volume 2, Issue 1, January-2013.
- [8] F.F. Mammadov, "Estimation of Flat Plate Solar Collector Productivity", International Journal on "Technical and Physical Problems of Engineering, Volume 4, Number 1, Issue 10, Pages 35-40, March 2012.

- [9] Sunil. K. Amrutkar, Satyshree Ghodke, Dr. K. N. Patil, "Solar Flat Plate Collector Analysis", IOSR Journal of Engineering, Vol. 2 Issue 2, Feb.2012, pp.207-213.
- [10] Madhukeshwara. N, E. S. Prakash, "An investigation on the performance characteristics of solar flat plate collector with different selective surface coatings", international journal of Energy and environment, Volume 3, Issue 1, 2012 pp.99-108.
- [11] Pravin N. Gajbhiye, Rupesh S. Shelke, "Solar energy concentration techniques in flat plate Collector", International Journal of Mechanical Engineering and Technology, Volume 3, Issue 3, Sep- Dec 2012.
- [12] Bhavesh Pandey, Bhavesh Pandey, "Automatic Sun Tracking System Using PSoC", International Journal of Innovative Research in Science, Engineering and Technology, Vol. 1, Issue 1, November 2012.
- [13] C. Bhuvaneswari, R. Rajeswari, C. Kalaiarasan, "Analysis of Solar Energy Based Street Light with Auto Tracking System", International Journal of Advanced Research in Electrical, Electronics and Instrumentation Engineering, Vol. 2, Issue 7, July 2013
- [14] Rashid Ahammed Ferdaus, Mahir Asif Mohammed, Sanzidur Rahman, Sayedus Salehin, and Mohammad AbdulMannan, "Energy Efficient Hybrid Dual Axis Solar Tracking System", Journal of Renewable Energy, Volume 2014.
- [15] Nader Barsoum, "Fabrication of Dual-Axis Solar Tracking Controller Project", Intelligent Control and Automation, May 2011, 2, 57-68.
- [16] Meghana Sharma, "An Efficient Low Cost Solar Tracker Using Microcontroller", IOSR Journal of Electrical and Electronics Engineering, Volume 9, Issue 4 Ver. V (Jul – Aug. 2014), PP 37-40.
- [17] Sanjay Sharma, "Automatic sun-tracking solar cell array system", International Journal of Advanced Engineering Research and Studies, Vol. I, Issue II, January-March, 2012, pp:162-166.
- [18] Deepthi. S, Ponni. A, Ranjitha. R, R Dhanabal, "Comparison of Efficiencies of Single-Axis Tracking System and Dual-Axis Tracking System with Fixed Mount", International Journal of Engineering Science and Innovative Technology, Volume 2, Issue 2, March 2013.
- [19] Mostefa Ghassoul, "Design of an Automatic Solar Tracking System to Maximize Energy Extraction", International Journal of Emerging Technology and Advanced Engineering, Volume 3, Issue 5, May 2013.
- [20] Soumen Ghosh, Nilotpal Haldar, "Solar Tracking System using AT89C51 Microcontroller and LDR", International Journal of Emerging Technology and Advanced Engineering, Volume 4, Issue 12, December 2014.
- [21] Pooja K. Chhatwani, Jayashree S. Somani, "Intelligent Solar Tracker System Implemented on 8051 Microcontroller", International Journal of Engineering Trends and Technology, Volume 4 Issue 9-Sep 2013.
- [22] Md. Tanvir Arafat Khan, S.M. Shahrear Tanzil, Rifat Rahman, S M Shaful Alam, "Design and Construction of an Automatic Solar Tracking System", 6th International Conference on Electrical and Computer Engineering ICECE 2010, 18-20 December 2010, Dhaka, Bangladesh.
- [23] Tiberiu Tudorache, Liviu Kreindler, "Design of a Solar Tracker System for PV Power Plants", Acta Polytechnica Hungarica Vol. 7, No. 1, 2010.
- [24] K.K. Goyal, "Renewable Energy" ISBN: 978-81-8377-243-3, 2005.
- [25] Noor H Jabarullah, "The controversy of biofuel versus fossil fuel, International Journal of Advanced and Applied Sciences, 3(2) 2016, pp:11-14.