

# Intelligent Irrigation Control System Using Wireless Sensors and Android Application

Rajeshwari Madli, Santhosh Hebbar, Vishwanath Heddoori, G. V. Prasad

**Abstract**—Agriculture is the major occupation in India and forms the backbone of Indian economy in which irrigation plays a crucial role for increasing the quality and quantity of crop yield. In spite of many revolutionary advancements in agriculture, there has not been a dramatic increase in agricultural performance. Lack of irrigation infrastructure and agricultural knowledge are the critical factors influencing agricultural performance. However, by using advanced agricultural equipment, the effect of these factors can be curtailed. The presented system aims at increasing the yield of crops by using an intelligent irrigation controller that makes use of wireless sensors. Sensors are used to monitor primary parameters such as soil moisture, soil pH, temperature and humidity. Irrigation decisions are taken based on the sensed data and the type of crop being grown. The system provides a mobile application in which farmers can remotely monitor and control the irrigation system. Also, the water pump is protected against damages due to voltage variations and dry running.

**Keywords**—Android application, Bluetooth, humidity, irrigation, soil moisture, soil pH, temperature, wireless sensors.

## I. INTRODUCTION

INDIA is the seventh largest country in the World, where Agriculture forms the source of livelihood for more than 70% of Indians. Despite rapid industrialization, agriculture remains a dominant sector of Indian economy in terms of both Gross Domestic Product (GDP) and source of employment. Indian agricultural sector contributes about 18% to GDP and employs nearly 50% of the country's population [1]. According to the New York Times edition published in 2008 [2], with the use of appropriate technology and right policies, India cannot only feed itself but the entire world.

Ancient agriculture in India was largely dependent on monsoons. As monsoon rainfall occurs only for four to five months in a year, it was impossible for the farmers to cultivate their farms throughout the year, and this was leading to low crop yield and financial crisis. With the green revolution that took place in late 1960's, the irrigation infrastructure was expanded to modern equipment such as electric motor pumps for supplying water to crops. However, this modern equipment requires physical presence of farmers in the field in order to monitor their working status and avoid water and electricity wastage. Also, crops have different water requirements at different stages of their growth, which need to be addressed during irrigation. Soil and environment parameters such as soil moisture, temperature, humidity and soil PH play a crucial

role in determining the water requirement of crops. Most of the irrigation systems currently used in India do not consider these factors and this problem needs to be addressed in order to increase crop yield. Fig. 1 shows irrigation systems that are currently used by most farmers in India. Water from reservoirs such as canals or bore well is lifted by water pumps and supplied to farms.



Fig. 1 A typical irrigation system [15]

The presented system makes use of wireless sensors to control the irrigation process based on the water and nutrition requirements of the crop being grown. This in turn helps to reduce wastage of water and electricity.

## II. RELATED WORK

Wireless Sensor Networks (WSNs) have brought a paradigm shift in agricultural practices, which have inspired many researchers to work in this area. This section briefly describes some of the works that make use of WSNs to aid agricultural processes.

Abbas et al. [3] proposed a smart irrigation system for gardens that makes use of wireless sensors. It uses moisture sensors that not only detect the moisture content in soil, but also help in identifying various soil characteristics such as water holding capacity. The research aims at identifying the time taken by sensors to get activated based on which they can determine the duration of irrigation. The fact that different plants consume different amounts of water in different seasons is considered in this system. Sensor nodes communicate with the wireless base station using ZigBee. The application in the base station logs data sent by sensor nodes and controls irrigation valves based on sensor inputs and the duration configured. However, the system does not take into account other factors such as soil pH, which play an important role in irrigating the plants. Ahmed et al. [4] have designed an automatic irrigation control system that makes use of an

Rajeshwari Madli, Santhosh Hebbar, Vishwanath Heddoori, and G.V. Prasad are with the Department of Computer Science and Engineering B.M.S College of Engineering, Bangalore 560019, India (e-mail: m.rajeshwari1626@gmail.com, santhoshhebbar@gmail.com, vishwanathheddoori@gmail.com, drvaraprasad@gmail.com).

adaptive irrigation algorithm to prevent plants from being over flooded. The system consists of four major parts namely, water level control, wireless messaging, security system and central control unit. The water level controller is responsible for detecting water level in the farm and signaling the microcontroller. Based on the output of water sensors, the microcontroller decides to turn on or turn off the pumps. If the fields are flooded, then the controller turns on a pump that removes excess water from the farm. Pumps and the control unit are prevented from unauthorized access with the help of password protection in the security system. The central control system sends wireless messages to the owner regarding security breach, pump condition and rains.

Gutiérrez et al. [5] developed a photovoltaic powered irrigation system to optimize water consumption using soil moisture sensors and temperature sensors. The system consists of two units, namely, Wireless Sensors Unit (WSU) and Wireless Information Unit (WIU). The WSU consists of several sensors to detect soil moisture and temperature and microcontroller unit receives sensed data. The data are then sent to the WIU using ZigBee. The WIU receives the data and compares moisture and temperature of soil to threshold values. If values are below threshold, then water motors are turned on. The system allows scheduled irrigation driven by setting date and time as well as manual operation by using a push button. The server contains a web application that allows remote monitoring and programming of the irrigation system. Since, the system allows remote monitoring through a web application, the user has to be connected to the internet for operating it. Peng and Liu [6] have proposed a fuzzy logic controlled intelligent irrigation system using wireless sensors. This work aims to optimize water consumption, by using sensors to detect soil humidity and air temperature. Sensor nodes measure soil humidity and air temperature and transfer to the coordinator node. The coordinator node consists of a fuzzy controller that makes decision about the duration of water flow based on soil humidity and temperature.

Dubey et al. [7] proposed a remote irrigation control system using wireless sensors and Dual Tone Multiple Frequency (DTMF) dialing. The system functions in two modes. A pre-programmed mode in which, the system controls irrigation pumps and valves based on the signals it receives from soil moisture sensors deployed in the farm. The second mode is program mode in which, the farmer can specify which sectors of farm to irrigate. In both modes, the system allows farmers to control irrigation (ON/OFF) using landline or mobile phone by dialing specific DTMF codes over GSM network. Although the system provides remote control facility, using DTMF is less user friendly and also offers lesser control options. Rajeev et al. [8] have proposed an irrigation system that functions with the help of SMS sent from a mobile phone. The system continuously monitors the electric motor and sends an SMS to the farmer's mobile phone indicating the availability of power supply to the motor. The farmer decides to turn on or turn off the motor by sending SMS to the system present at the farm and the system acts according the command received in the SMS. The farmer can also set a timer to turn off the motor

automatically. Apart from indicating availability of power supply, the system also indicates the voltage level available such as 1 phase and 3 phase. This system not only eliminates the need for the farmer to be physically present in the farm for operating the motor, but also saves water and electricity by scheduled motor turn off. However, it does not take into account the soil and atmospheric conditions before irrigating the land.

Zhao et al. [9] designed a middleware for agricultural appliances using WSNs that makes agricultural environment ubiquitous. The middleware collects agricultural data using wireless sensors, analyses it and offers intelligent diagnosis service. A web-based login allows users to refer to the agricultural parameters and their associated diagnosis. Users can also remotely access historic and current agricultural data as well as expert diagnosis. The data collected by sensors such as light, humidity, moisture and temperature are stored in a database. Here, authors have tried to bridge the gap between the sensed data and intelligent diagnosis. However, the system does not provide any control over irrigation process. Ahmad et al. [10] developed a smart water meter to measure canal water flow than can improve the equity of water distribution in the canals. Here, authors have focused on automating hourly measurements that helps concerned authorities to conduct region assessment and planning, resolve conflicts and ensure transparency. Ultrasonic sensors are used to measure the water level in the canal, which is time stamped and sent to the central server using GSM. The server calibrates the values and makes them user readable and stores in the database. Users can then login to the server to access the various parameters such as water level and discharge per unit area. Farmers can make use of this information for irrigating their farms. However, the system does not provide any automation assistance to control the irrigation system.

Kannan and Thilagavathi [11] proposed an online farming system based on WSNs that helps farmers to remotely monitor and control the agricultural processes in their farms through the website. The system is made up of three modules. The front end module consists of various sensors for collecting parameters such as temperature, soil moisture, water level and fertility. Wireless IP cameras are installed to capture the live conditions of the farm. All this information is transmitted to management module using ZigBee. The collected data are compared to standard values from the database and necessary actions such as controlling the irrigation valve are performed. It also responds to the commands received from the remote monitoring module. The remote monitoring module is the farming website that allows users to monitor and control various parameters of their farms. The authors here have focused on implementing remote farming using which agricultural processes can be controlled from any part of the world. Divya et al. [12] proposed a context aware wireless irrigation system that automates sprinkler irrigation based on various agricultural contexts. This work concentrates on important factors related to hydrology, soil, crops and other environmental factors for designing the irrigation system. They also propose a design for horizontal angle adjustment for

sprinkler nozzle with the help of stepper motor. With this design, it is possible to reduce consumption of water in sprinkler irrigation due to various problems related to water supply. But, the system does not provide any remote irrigation control features.

Baviskar et al. [13] designed an interactive voice response system for controlling irrigation process using an authorized GSM mobile phone. The system consists of two units; Pump Control Unit (PCU) and Farm Control Unit (FCU). FCU monitors the soil moisture and controls irrigation valves and PCU controls the working of pump depending on the water level available in the tank. Both are driven by voice command received from user's mobile phone and soil moisture and water level details collected. The use of cellular communication however increases the communication delay and hence reduces the operational efficiency.

### III. ARCHITECTURE OF PRESENTED SYSTEM

Fig. 2 shows the architecture of the proposed system. It consists of four major components- monitoring unit installed in the farm, control unit installed in the pump house, server mobile placed close to the control unit and a remote client mobile. Monitoring unit, which is placed in the field, monitors important agricultural parameters such as soil moisture, soil pH, temperature and humidity, and transfers the data to the server mobile. The server mobile, which is placed in the pump house close to the control unit, processes the sensed information and makes appropriate irrigation decisions. It also serves remote client requests coming from the client mobile. The server mobile sends commands to the control unit for controlling the irrigation process, based on inputs given by monitoring unit and client mobile. The control unit controls the working of water motor and solenoid valves accordingly.

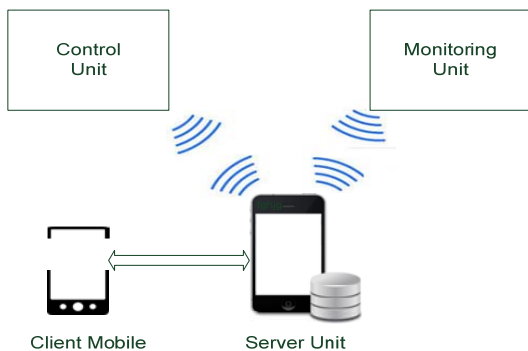

Fig. 2 System architecture

### IV. IMPLEMENTATION

Implementation of the proposed system is divided into four modules; monitoring unit, control unit, server application, and client application.

#### A. Monitoring Unit

The block diagram for implementing monitoring unit is shown in Fig. 3. It contains a microcontroller, a soil moisture

sensor, a soil pH sensor, temperature sensor, and a humidity sensor.

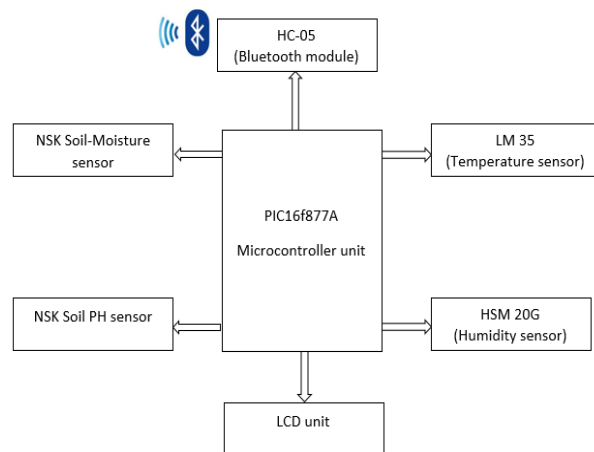

Fig. 3 Block diagram of monitoring unit

The main function of monitoring unit is to monitor the field parameters; soil moisture, soil pH, atmospheric temperature and humidity. The microcontroller unit is realized by using PIC16f877A, which is responsible for collecting the parameters sensed by sensors, and transfer to the server mobile phone for processing via the Bluetooth interface using HC-05 Bluetooth module. Soil moisture and pH sensors are inserted in the soil, whereas temperature and humidity sensors measure the atmospheric temperature and humidity. These sensors act in semi-passive mode as they are powered by battery [14]. The monitoring unit is placed in the field to monitor the agricultural parameters.

#### B. Control Unit

Fig. 4 shows a detailed block diagram of the control unit, which consists of a microcontroller, Bluetooth module, voltage measuring unit and water pressure switch. The control unit operates the water pump and solenoid valves using a relay circuit.

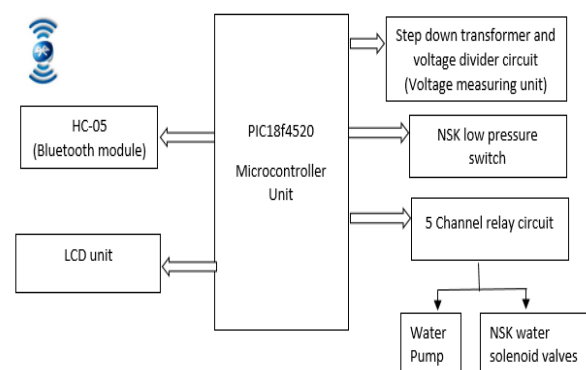

Fig. 4 Block diagram of control unit

The main function of control unit is to operate the water pump and solenoid valves based on the commands sent by the

server mobile phone. It makes use of HC-05 Bluetooth module to communicate with the server unit. Another important function of control unit is to protect the motor against damages due to voltage variation and low water pressure. It monitors the input voltage with the help of step down transformers and voltage divider network, and turns it off in the absence of 3 phase voltage. It also monitors the water pressure in the reservoir using a low pressure switch, and turns off the motor if there is no sufficient water pressure, thus preventing dry running of motor.

The work flow of control unit is shown in Fig. 5. Control unit starts by reading input phase voltage values and checks if there is enough voltage to run the water pump. If 3 phase voltage is not available, then it immediately stops the motor to avoid its damage. The control unit then starts listening to Bluetooth serial port for incoming commands sent by server unit and operates accordingly to control the water pump and solenoid valves.

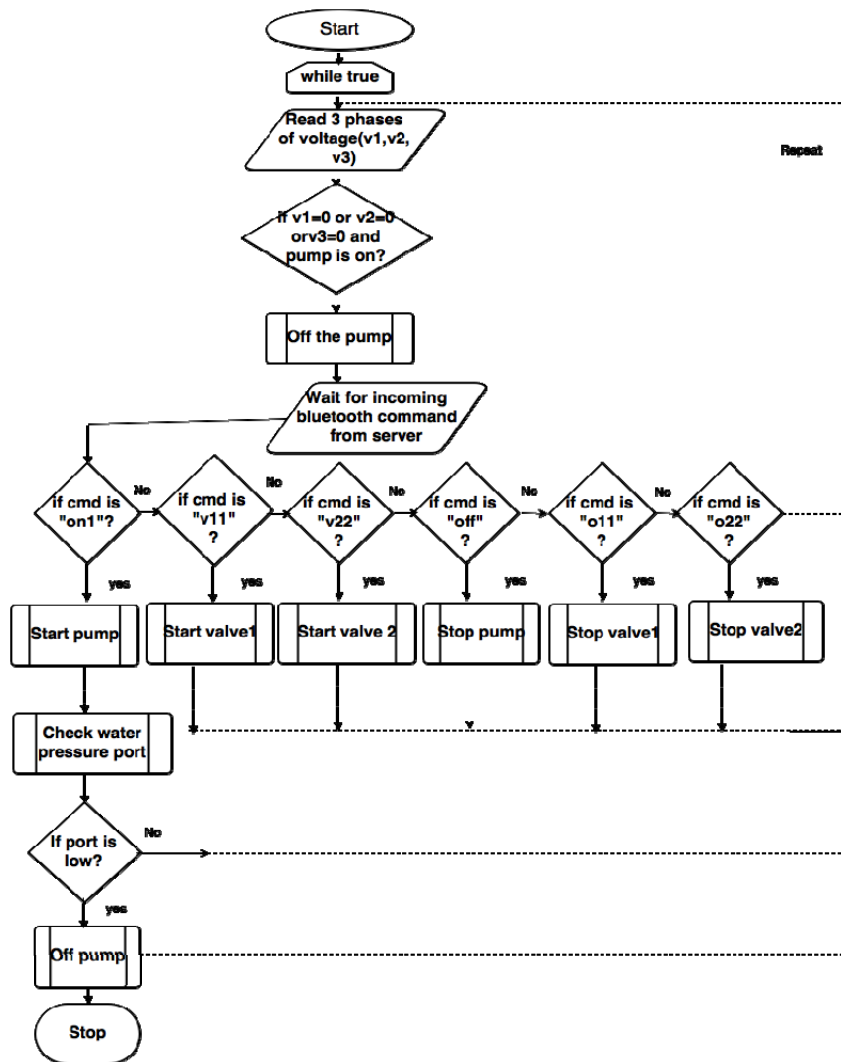

Fig. 5 Work flow of control unit

### C. Client Application

Client application is an android application that runs on user's mobile phone and performs five functions to help users to remotely monitor and control the irrigation process. Fig. 6 shows the home page of client application.

The following are the functions of client application.

#### 1. On/Off

This function allows users to remotely control the working of water pump. If user clicks "ON" or "OFF", then the application encodes the command into an SMS and sends to the server mobile, placed in the pump house. This SMS is encoded as "on1" for ON and "off" for OFF functions.



Fig. 6 Main page of client application

## 2. Set Time

This feature allows user to select the solenoid valves and duration in minutes for which they should be turned on. This information is encoded into a string and sent to server mobile. The SMS is encoded as “*set,x,a,b,c,d*”, where *x* is duration in minutes, *a,b,c,d* correspond to valves selected by user. After the specified duration is lapsed, the valves are turned off.

## 3. Schedule

This feature allows user to schedule irrigation process from a remote place. The user selects date, time, solenoid valves and duration in minutes to schedule the process. This information is encoded into a string and sent to the server. The message is encoded as “*sch,p,q,r,x,y,z,a,b,c,d*”, where *p, q, r* correspond to a particular date, *x* and *y* are hour and minute at which irrigation should be scheduled and *a,b,c,d* correspond to valves selected by user. Some crops need to be watered on a daily basis and some on a bi-weekly basis. The “Schedule” feature is of great help to farmers, using which, they can simply schedule the process and forget about it.

## 4. Get Irrigation Status

This feature allows user to find out the status of irrigation system installed in the farm. When user clicks on “Get Irrigation Status”, “*gis*” message is sent to server. The server sends information such as motor status, valves’ status and the current parameter values sensed by sensors. The server response is decoded and displayed on the mobile screen in a suitable form.

## 5. Get Information

This feature displays a table of standard values of soil moisture, temperature, humidity and soil PH values for different types of crops. Using this as a reference, users can make use of above mentioned functionalities and take right irrigation decisions.

### D. Server Application

Server application runs in the background of server mobile phone, placed in proximity of the control unit. This unit is a crucial part of the irrigation system as it handles all the data processing and decision making. It acts as an intermediate

system between control unit and outside World. It interacts with monitoring unit, client application and the external database. Fig. 7 shows the flowchart of server application.

On start, the server unit connects with the control unit and the monitoring unit via Bluetooth interface. It receives sensed parameters values from monitoring unit and processes them. It also checks these values against the threshold values (Ex: Temperature = 40 °C, moisture = 100%). If any variation is identified, then it makes necessary irrigation decisions such as switching on solenoid valves when moisture goes below 100 and sends a command to the control unit. The server application asynchronously listens to incoming SMS from the remote client and serves the requests by sending appropriate commands to control unit as follows:

- If user SMS contains “*on*” or “*off*”, then it sends “*on1*” or “*off*” command to control the water pump.
- If user SMS contains “*set,x,a,b,c,d*” (*x* is duration in minutes and *a,b,c,d* correspond to the valves selected by the user), then it sends a command as “*v11,v22,v33,v44*” indicating to turn on all the valves. After “*x*” minutes, it sends a command as “*o11, o22, o33, o44*” to turn off all the valves.
- If user SMS contains “*sch,p,q,r,x,y,z,a,b,c,d*” (*p, q, r* correspond to date. *x* and *y* correspond to hour and minute at which irrigation has to be scheduled, *z* is duration in minutes, *a,b,c,d* are valves selected by the user), then it starts the irrigation process at the scheduled time by sending a command as “*v11,v22,v33,v44*” indicating to turn on all the valves. After *x* hours, *y* minutes, it sends a command as “*o11, o22, o33, o44*” to turn off all the valves.
- If user SMS contains “*gis*” (get irrigation status), then it collects the current irrigation status such as motor status, voltage status and other sensor values and sends to the user mobile.

## V. EXPERIMENTAL RESULTS

This section gives the snapshots of the proposed system and describes some sample results. Fig. 8 (a) shows the working model of monitoring unit, and 8b shows the working model of control unit and server mobile phone. The proposed system was tested in an artificial agricultural environment consisting of vegetable plants grown in plastic pots. Various tests were conducted with all possible combination of inputs and the results were satisfying.

Table I shows the parameter values sensed by sensors deployed in the pots. The values were recorded at different points of time during the day. Here, soil moisture is lesser at 9:00 a.m., making the soil slightly acidic, which is indicated by soil pH value, 06. It was found that after irrigating the plant, soil moisture and pH values raised.

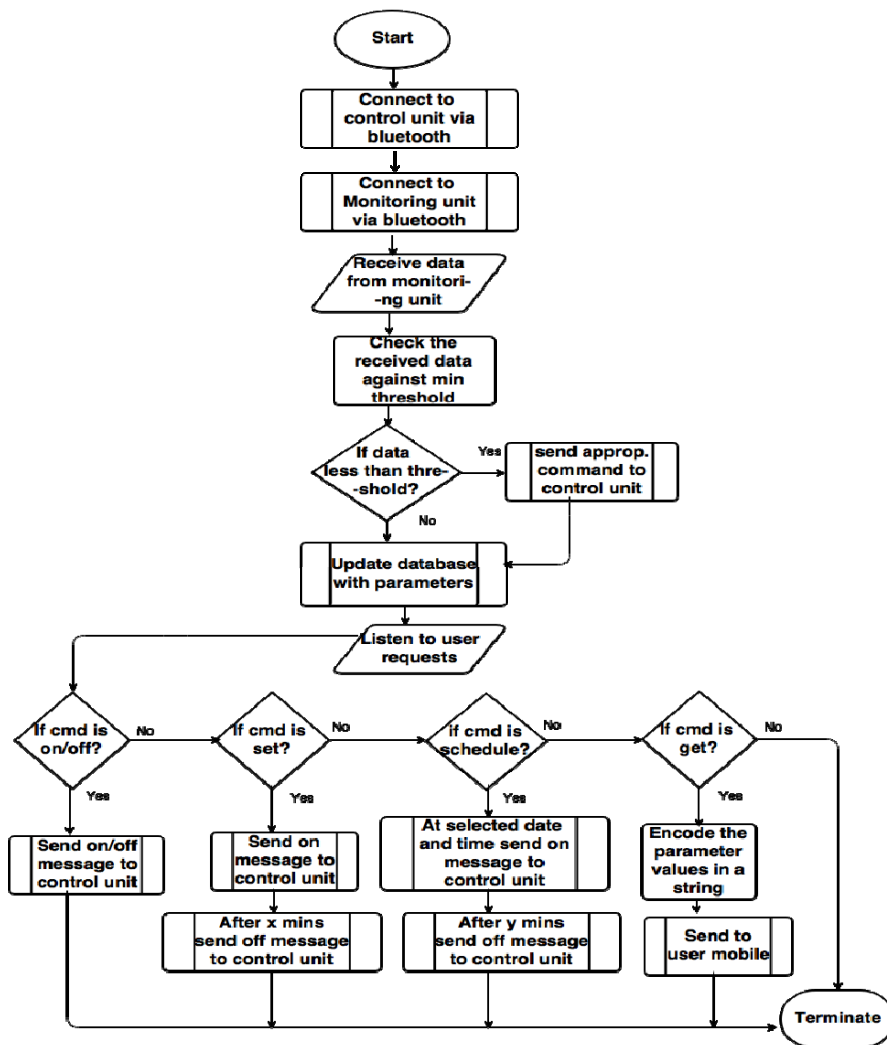

Fig. 7 Flowchart of server application

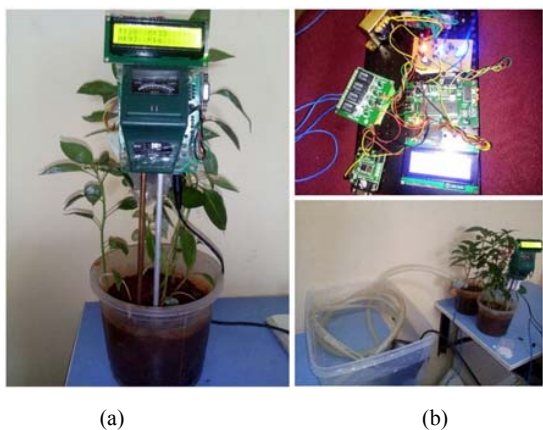

Fig. 8 (a) Working model of monitoring unit, (b) Working model control unit

voltage indicating values for 3 phases. The second line shows the status of power supply and phase. The third and fourth lines show the status of water pump and solenoid valves.

TABLE I  
PARAMETER VALUES SENSED BY SENSORS

Time	Soil Moisture (%)	Soil pH	Temperature (°C)	Humidity (%)
09:00am	95	06	28	89
11:00am	100	07	29	85
1:00pm	98	07	31	83
3:00pm	98	06	31	84
5:00pm	96	06	30	86
7:00pm	95	07	28	89

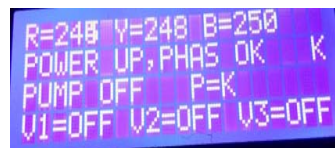

Fig. 9 Initial status of control unit

Fig. 9 shows the initial status of control unit displayed on the LCD screen attached to it. The first line shows the input

Fig. 10 shows irrigation status with water pump and all solenoid valves switched on. The second line on the LCD shows the command received by control unit from the server mobile phone. On a similar basis, the working of the irrigation system was tested by sending commands with all possible combinations from server unit.

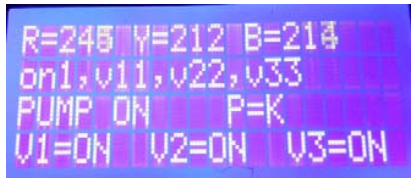

Fig. 10 Sample status of irrigation system

#### VI. CONCLUSION AND FUTURE SCOPE

The intelligent irrigation controller, proposed in this paper, automates the irrigation process by sensing primary agricultural parameters such as soil moisture, soil PH, temperature and humidity. Also, the system allows farm owners to remotely monitor and control the irrigation system with the help of a user friendly mobile application, making the entire system ubiquitous. The proposed solution protects the water pump against damages by monitoring input voltage and water pressure. Use of mobile phone as a server and Bluetooth module for communication, reduces the cost involved in processing and communication. Thus, the system offers a cost effective solution for controlling the irrigation process and boosting the crop yield.

Although, the proposed system stores field parameters into the database periodically, it does not make use of these data for further processing. These data can be further used by irrigation experts for analytical studies and improving irrigation decisions to enhance agricultural yield. The system can be further enhanced by using RF chips and repeaters to enable long range communication and eliminate the use of GSM altogether.

#### REFERENCES

- [1] "Key Economic Sectors: Agriculture", Available online: [http://indiainbusiness.nic.in/newdesign/index.php?param=economy\\_land ing/213/2](http://indiainbusiness.nic.in/newdesign/index.php?param=economy_land ing/213/2), Accessed: 03/06/2015.
- [2] "In Fertile India, Growth Outstrips Agriculture", Available online: [http://www.nytimes.com/2008/06/22/business/22indiafood.html?pagewanted=all&\\_r=0](http://www.nytimes.com/2008/06/22/business/22indiafood.html?pagewanted=all&_r=0), Accessed: 10/04/2015.
- [3] Ahmed Hussein Abbas, Maya Medhat Mohammed, "Smart Watering System for Gardens using Wireless Sensor Networks", *In Proceedings of International Conference on Engineering and Technology*, pp.1-5, 2014.
- [4] Md. Mobasher Ahmed, Ezaz Ahmed, Kazi Tanvir Ahmed, "Automated Irrigation Control and Security System with Wireless Messaging", *In Proceedings of International Conference on Informatics, Electronics and Vision*, pp.1-5, 2013.
- [5] Joaquín Gutiérrez, Juan Francisco Villa-Medina, Alejandra Nieto-Garibay, Miguel Ángel Porta-Gándara, "Automated Irrigation System Using a Wireless Sensor Network and GPRS Module", *IEEE Transactions on Instrumentation and Measurement*, Vol. 63, No. 1, pp.166-176, 2013.
- [6] Xiaohong Peng, Guodong Liu, "Intelligent Water-Saving Irrigation System Based on Fuzzy Control and Wireless Sensor Network", *In Proceedings of International Conference on Digital Home*, pp 252-256, 2012.
- [7] Vandana Dubey, Nilesh Dubey, Shailesh Singh Chouhan, "Wireless Sensor Network based Remote Irrigation Control System and Automation using DTMF code", *In Proceedings of International Conference on Communication Systems and Network Technologies*, pp.34-37, 2011.
- [8] Rajeev G. Vishwakarma, Vijay Choudhary, "Wireless Solution for Irrigation in Agriculture", *In proceedings of International Conference on Signal Processing, Communication, Computing and Networking Technologies*, pp.61-63, 2011.
- [9] Liang Zhao, Liyuan He, Xing Jin, Wenjun Yu, "Design of Wireless Sensor Network Middleware for Agricultural Applications" In: Daoliang Li, Yingyi Chen eds. *Computer and Computing Technologies in Agriculture IV*, Springer Berlin Heidelberg, pp 270-279, 2012.
- [10] Zahoor Ahmad, Ehsan U. Asad, Abubakr Muhammad, Waqas Ahmad, Arif Anwar, "Development of a Low-Power Smart Water Meter for Discharges in Indus Basin Irrigation Networks", In: Faisal Karim Shaikh, Bhawani Shankar Chowdhry, Habib M. Ammari, Muhammad Aslam Uqaili, Assadullah Shah eds. *Wireless Sensor Networks for Developing Countries*, Springer Berlin Heidelberg, pp.1-13, 2013.
- [11] Sathish Kannan K., Thilagavathi G., "Online Farming Based on Embedded Systems and Wireless Sensor Networks", *In Proceedings of International Conference on Computation of Power, Energy, Information and Communication*, pp.71-74,2013.
- [12] Divya P., Surbhi Sonkiya, Preeti Das, Manjusha V. V, Maneesha V. Ramesh, "CAWIS: Context Aware Wireless Irrigation System", *In Proceedings of International Conference on Computer, Communications, and Control Technology (I4CT)*, pp 310-314, 2014.
- [13] Baviskar, J.J. , Mulla, A.Y. , Baviskar, A.J. , Dsouza, K. , Khan M., "Designing of Mobile Controlled Automatic Interactive Voice Response Irrigation System", *In Proceedings of International Conference on Recent Advances and Innovations in Engineering*, pp.1-6,2014.
- [14] Shuang-Ming Yu, Peng Feng, Nan-Jian Wu, "Passive and Semi-Passive Wireless Temperature and Humidity Sensors Based on EPC Generation-2 UHF Protocol", *IEEE Sensors Journal*, Vol.15, No.4, pp.2403-2411, 2014.
- [15] "Pumps, Modern", Available online: <http://www.waterencyclopedia.com/Po-Re/Pumps-Modern.html>, Accessed: 15/04/2015.