

Maximum Power Point Tracking Based on Estimated Power for PV Energy Conversion System

Zainab Almkhtar, Adel Merabet

Abstract—In this paper, a method for maximum power point tracking of a photovoltaic energy conversion system is presented. This method is based on using the difference between the power from the solar panel and an estimated power value to control the DC-DC converter of the photovoltaic system. The difference is continuously compared with a preset error permitted value. If the power difference is more than the error, the estimated power is multiplied by a factor and the operation is repeated until the difference is less or equal to the threshold error. The difference in power will be used to trigger a DC-DC boost converter in order to raise the voltage to where the maximum power point is achieved. The proposed method was experimentally verified through a PV energy conversion system driven by the OPAL-RT real time controller. The method was tested on varying radiation conditions and load requirements, and the Photovoltaic Panel was operated at its maximum power in different conditions of irradiation.

Keywords—Control system, power error, solar panel, MPPT.

I. INTRODUCTION

THE demand on energy is rapidly increasing. Statistic indicates that the worldwide increase is 2% yearly while the increase in developing countries like India and China is 6% and 4% yearly, respectively. The main source of energy until today is fossil fuel which is crude oil and natural gas, and is estimated to make 80% of the whole energy use. Other energy sources like coal and nuclear have concerns about the cost and safety. Therefore, renewable energy sources, such as wind and solar, represent a valuable option for electricity production as they are clean.

The large consumption of fossil fuel has caused serious issues like global warming and pollution due to the raising of the atmospheric concentration of CO₂ and greenhouse gases. The other concern is that fossil fuel is prone to run out in about 50 years [1], [2]. In order to face those growing challenges, clean and renewable energy sources, such as solar and wind, can satisfy the raising demand of energy. It is needed to diversify the energy uses with a gradual transformation to the use of renewable energy. For this reason, it is important to conduct more research and development in harnessing energy from the sun and the wind.

In order to extract the maximum power from the solar photovoltaic (PV) source, it is required to operate at a current-voltage value that achieves the maximum power. The process

is called Maximum Power Point Tracking (MPPT) [3]. Different techniques are used to determine the point that provides the maximum power. Several maximum point tracking techniques, both traditional and intelligent as well as hybrid, have been studied. These techniques include fractional open-circuit voltage (FOCV), look-up table, one-cycle control (OCC), feedback of power variation with current, perturbation and observation (P&O), hill-climbing, incremental conductance (Inc.-Cond), forced oscillation, ripple correlation control (RCC), as well as fuzzy and neural networks techniques [4]-[7].

Classical mathematical root finding techniques have been successfully applied to power point tracking. These techniques include Raphson method, bisection method, and regula-falsi method. MPPT methods vary in complexity of implementation, how fast they reach the maximum power point, the oscillation around the maximum power point, the ability to work under varying conditions and the accuracy, as well as the number of sensors needed and the cost [8]-[12].

Although short-circuit current and open-circuit voltage methods involve no differentiation and are simpler to implement, they have some drawbacks such as the requirement of updating voltage and current values at every instant in consecutive time intervals, which results in loss of power, and the estimated values can be far from the real ones and only gives approximate results [9].

II. PV ENERGY SYSTEM

A. Modeling of Solar Cell

The electrical characteristics of the solar cell are nonlinear and can be modeled by the following equivalent circuit [13].

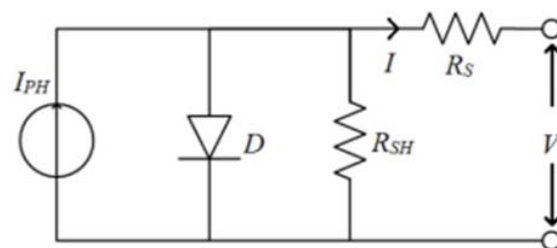

Fig. 1 Characteristics of the solar cell

The current-voltage equation, from the equivalent circuit, is given by

$$I = I_{PH} - I_S \left(\exp \left(\frac{q(V + IR_S)}{NKT} \right) - 1 \right) - \frac{V + R_S I}{R_{SH}} \quad (1)$$

Z. Almkhtar is a graduate student in the Master of Technology Entrepreneurship & Innovation at Sobeys School of Business, Saint Mary's University, Halifax, NS, Canada, (e-mail: zalmukhtar@smu.ca).

A. Merabet is an Associate Professor at the Division of Engineering, Saint Mary's University, Halifax, NS, Canada (e-mail: adel.merabet@smu.ca).

where, I is the load current, I_{PH} is the photocurrent, I_S is the diode saturation current, q is the electron charge, V is the terminal voltage of the cell, N is the diode ideality factor, K is the Boltzmann constant, T is the cell temperature, R_S and R_{SH} are the series and shunt resistances, respectively.

The PV panel is made of a number of solar cells, which makes its behavior nonlinear and completely dependent on these parameters.

Fig. 2 shows the relation between the voltage, current and power from a PV cell. The black curve is the current-voltage variation, and the green curve shows the power changes with different values of voltage and current. It can be observed that there is a point of voltage and current where the power, attained from the solar cell, is the maximum. This point is called the maximum power point (MPP). The current at this point is called maximum power point current (I_{MPP}), and the voltage is the maximum power point voltage (V_{MPP}) [12]. Fig. 3 shows the current-voltage curve at different values indicating that the above statement is true in any operating condition.

At certain conditions, of temperature, radiation and load value, the solar cell would be operating at the MPP. The online tracking of the MPP of a PV system becomes essential, in which power point is continuously tracked when load conditions or other conditions that affect the solar energy would change.

B. PV Energy Conversion System

In order to make the solar panel operating at the MPP, a buck-boost or boost converter is connected to the panel and controlled to obtain the necessary voltage and current values to achieve this point. The duty cycle of the DC-DC converter is changed according to the MPPT controller and by this, the DC-DC converter will operate to produce the voltage that would achieve the maximum power as shown in Fig. 4.

In this work, a boost converter is used in order to raise the voltage from the solar panel to provide the V_{MPP} according to the resistive load requirements. The schematic of the PV energy conversion system is shown in Fig. 5.

III. MPPT BASED ON ESTIMATED MAXIMUM POWER

The proposed method depends on the power difference between an estimated maximum power (P_e) and the actual power from the PV panel (P_{pv}). If the difference is greater than a permitted error value (ϵ), the estimated value for the power will be multiplied by a factor (k), and the process will stop when the difference between the estimated and the actual power is equal or less than the error value. The value for k can be chosen 1 to 2, usually 1.5. This works to increase the estimated power in gradual steps until the error is within the permitted error value.

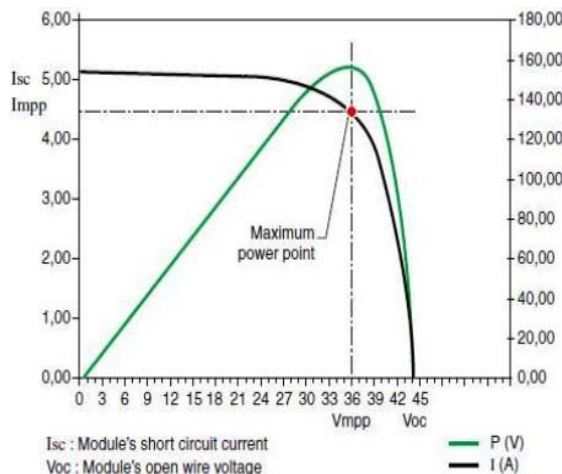

Fig. 2 I-V and P-V curves under similar operating conditions

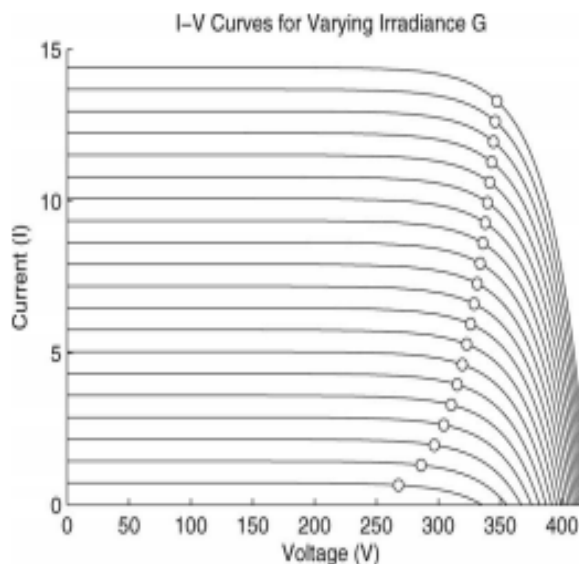

Fig. 3 I-V curves under difference operating conditions

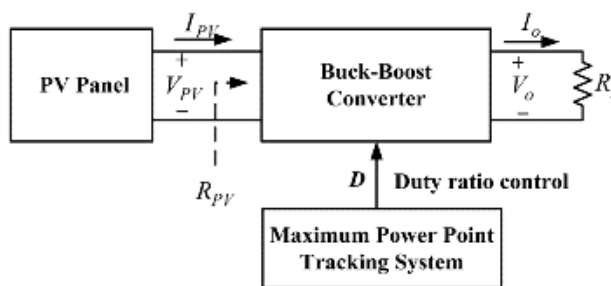

Fig. 4 PV energy conversion system and MPPT

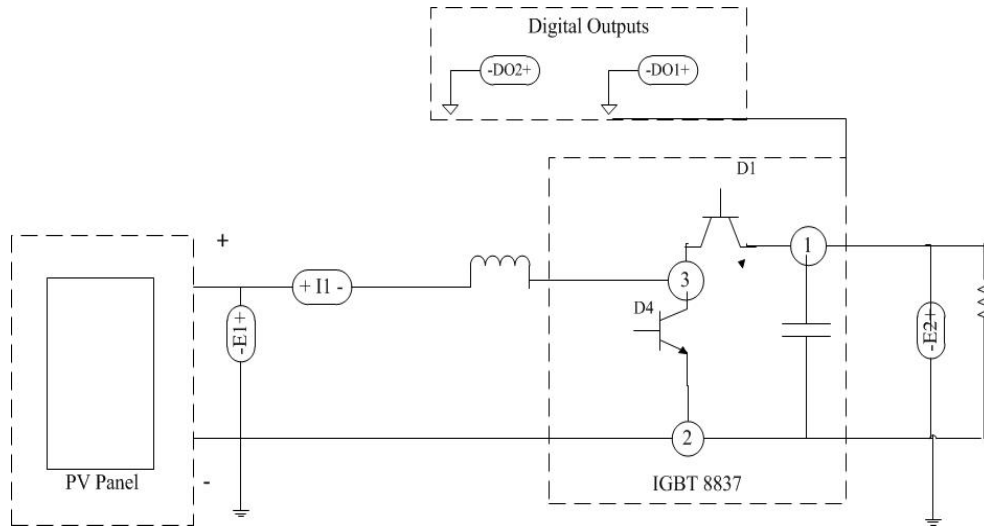

Fig. 5 Configuration of the PV energy conversion system

The power from the solar panel is given by

$$P_{pv} = V_{vp} I_{vp} \quad (2)$$

The power error E (difference between the estimated power and the actual PV power) is expressed as

$$E = P_e - P_{pv} \quad (3)$$

The estimated power is updated as

$$P_e = k P_e \quad (4)$$

In order to start the process, a random value will be assigned to the initial value of the estimated power.

The flow chart in Fig. 6 shows the proposed MPPT algorithm. The power error E will feed a PID controller, which will provide the signal to fire the gate of the boost converter that will increase the voltage to the value required for the maximum power. This method proved to be simple as no derivations for the voltage and the current values are needed which reduces the complexity of the MPPT system. It is less cumbersome in mathematical and analytical equations, which makes it easier than the smart methods like the fuzzy and the neural networks, and can be applied for general uses. This will lead to a fast convergence to the maximum power point despite the changes in radiation or atmospheric conditions.

IV. EXPERIMENTAL SETUP

The experimental setup, used to verify the proposed MPPT strategy, consists of a solar panel, a DC-DC boost converter, an inductive filter, a resistive load, OPAL-RT data acquisition interface, for voltage and current measurements, and OPAL-RT real time controller. The MPPT strategy is built in Simulink and executed in OPAL-RT real time simulator through the RT-Lab software. The overall system is depicted in Fig. 7, where the solar panel is connected to the boost

converter, which is connected to the load. The current and voltage to the circuit are measured and the signals to the converter are directed through the data acquisition panel, by the controller algorithm specified in the flow-chart (Fig. 6).

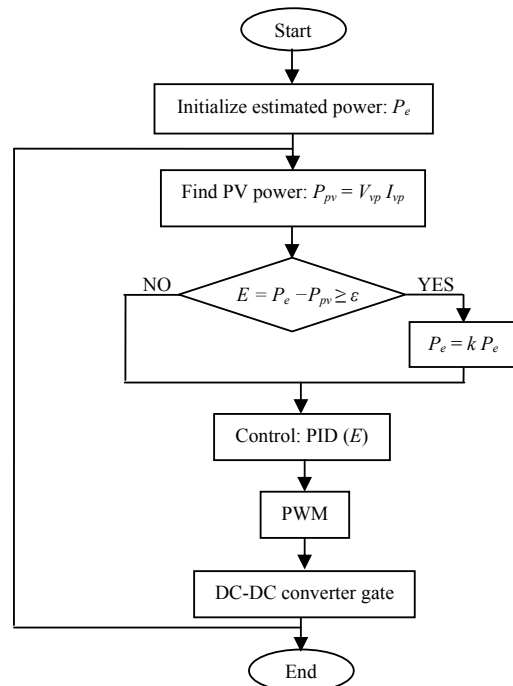

Fig. 6 Flow-chart of the proposed MPPT method

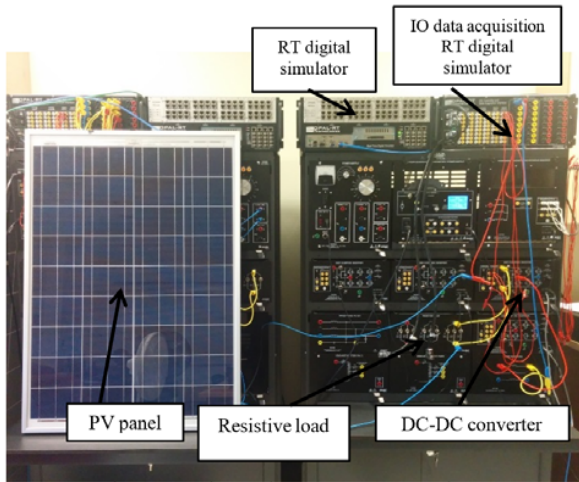

Fig. 7 Experimental PV energy conversion system

V. EXPERIMENTAL RESULTS

The system was operated at different solar radiation conditions to supply a resistive load. The irradiation was varied by turning ON/OFF different lights. Voltage and current at the panel side and voltage at the load side were measured by the data acquisition module and the pulses generated by the controller were sent to converter to fire the IGBT gates as shown in Fig. 5.

Results for various scenarios are shown in Figs. 8-10. In Fig. 8, the load voltage has been boosted to allow the system tracking the point that achieves maximum power, shown in Fig. 9, at different irradiation from $t=20s$. Other experiment result for a different voltage variation is shown in Fig. 10 and the equivalent generated power for the PV source is shown in Fig. 11. It can be observed that the PV voltage varies due to the variation of the irradiation conditions and the load voltage follows with a similar variation and is boosted for maximum power extraction.

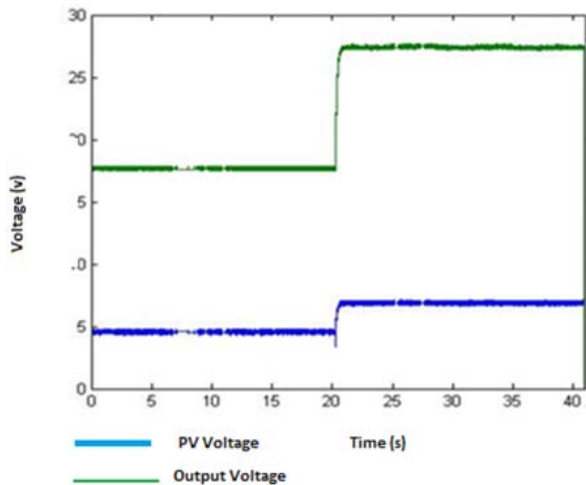

Fig. 8 Voltage variation at the solar panel and load

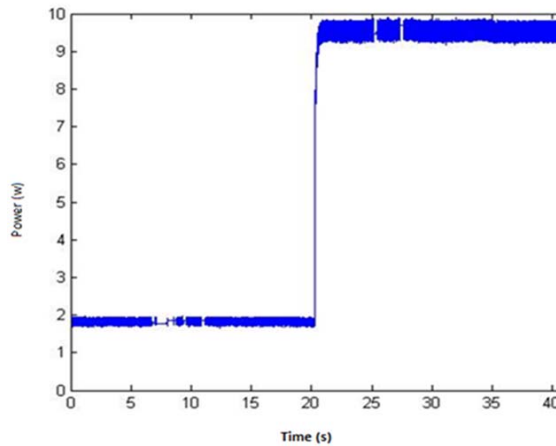

Fig. 9 Generated power by the solar panel

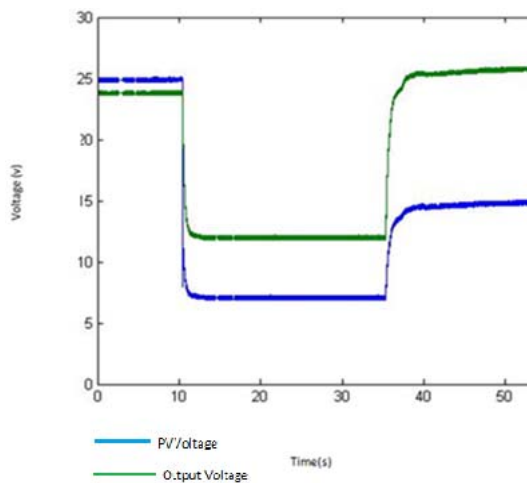

Fig. 10 Voltage variation at the solar panel and load for different irradianations

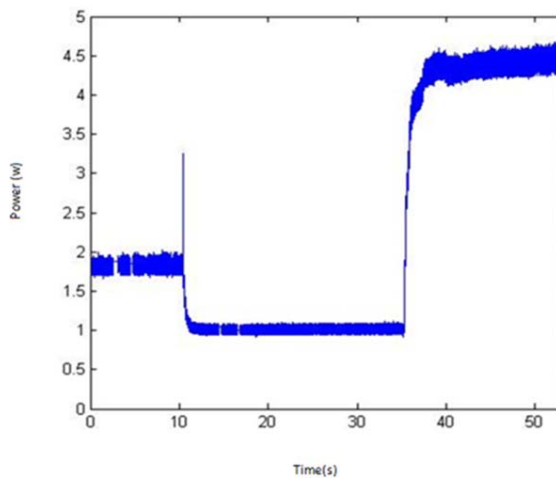

Fig. 11 Generated power by the solar panel for different irradianations

VI. CONCLUSION

In this paper, a simplified method for MPPT is presented and validated using an experimental PV energy conversion system. The method is based on comparing the power to a reference one generated by an estimation algorithm to control a converter for operation at maximum power extraction. The method has proved to be effective in operating at different irradiation conditions.

APPENDIX

TABLE I
UNITS FOR PV SYSTEM

Symbol	Quantity	Units
MPP	Maximum Power Point	Watts(w)
I_{pv}	Current from the PV Panel	Ampere(A)
V_{pv}	Voltage from the PV Pane	Volts(v)
P_{pv}	Power from PV Panel	Watt(w)
I	Load Current	Ampere (A)
P_e	Estimated Power Value	Watts (w)
E	Difference between estimated and PV power	Watts(w)

REFERENCES

- [1] R. Evans, *Fuelling our future*, UK: Cambridge Press, 2007.
- [2] P. Mobbs, *Energy beyond oil*, UK: Malador Publisher, 2005.
- [3] S. L. Brunton, C.W. Rowley, S.R. Kulkani, and C. Clarkson, "Maximum power point tracking for photovoltaic optimization using ripple-based extremum seeking control," *IEEE Trans. Power Electron.*, vol. 25, no. 10, pp. 2531–2538, Oct. 2010.
- [4] H-L. Tsai, C-S. Tu, and Y-J. Su, "Development of generalized photovoltaic model using MATLAB/SIMULINK," in *Proc. of the World Congress on Engineering and Computer Sc.*, Oct. 22–24, San Francisco, USA, 2008.
- [5] M. A. Islam, A. Merabet, R. Beguenane, and H. Ibrahim, "Power management strategy for solar stand-alone hybrid energy system," *World Academy of Science, Engineering and Technology*, vol. 8, no. 6, pp. 831–834, 2014.
- [6] Z. Zen, *Solar energy fundamentals and modeling technologies*, Springer, 2008.
- [7] V. L. Brano, A. Orioli, G. Ciulla, and A. D. Gangi, "A new five parameter module for PV Panels Application to Commercial Modules," Conf. on Thermal and Envir. Issues in Energy Syst., 16–19 May, Sorrento, Italy, 2010.
- [8] D. A. K. Seunghyun Chun, "Analysis of classical root-finding methods applied to digital maximum power point tracking for sustainable photovoltaic energy generation," *IEEE Trans. Power Electronics*, vol.26, no. 12, pp. 3730–3743, May 2011.
- [9] B. Subudhi, and R. Pradhan, "A comparative study on maximum power point tracking techniques for photovoltaic power systems," *IEEE Trans. Sustainable Energy*, vol. 4, no. 1, pp. 89–98, Jan. 2013.
- [10] N. Femia, G. Petrone, G. Spagnuolo, and M. Vitelli, "Optimization of perturb and observe maximum power point tracking methods," *IEEE Trans. Power Electron.*, vol. 20, no. 4, pp. 963-973, Jul. 2005.
- [11] M. Azeb, "A new maximum power point tracking for photovoltaic systems," *Int. J. of Elec., Comp., Energetic, Electron. and Comm. Eng.*, vol. 2, no. 8, pp. 1600-1603, 2008.
- [12] H. Kawamura, K. Naka, N. Yonekura, S. Yamanaka, H. Kawamura, H. Ohno, and K. Naito, "Simulation of I–V characteristics of a PV module with shaded PV cells," *Solar Energy Materials and Solar Cells*, vol. 75, no. 3–4, p. 613–621, 2003.
- [13] R. Gupta, G. Gupta, D. Kastwar, A. Hussain, and H. Ranjan "Modeling and design of MPPT controller for a PV module using PSCAD/EMTDC," *IEEE PES Innovative Smart Grid Technologies Conference Europe*, Oct. 11–13, Gothenburg, Sweden, pp. 1–6, 2010.