

Design of IMC-PID Controller Cascaded Filter for Simplified Decoupling Control System

Le Linh, Truong Nguyen Luan Vu, Le Hieu Giang

Abstract—In this work, the IMC-PID controller cascaded filter based on Internal Model Control (IMC) scheme is systematically proposed for the simplified decoupling control system. The simplified decoupling is firstly introduced for multivariable processes by using coefficient matching to obtain a stable, proper, and causal simplified decoupler. Accordingly, transfer functions of decoupled apparent processes can be expressed as a set of n equivalent independent processes and then derived as a ratio of the original open-loop transfer function to the diagonal element of the dynamic relative gain array. The IMC-PID controller in series with filter is then directly employed to enhance the overall performance of the decoupling control system while avoiding difficulties arising from properties inherent to simplified decoupling. Some simulation studies are considered to demonstrate the simplicity and effectiveness of the proposed method. Simulations were conducted by tuning various controllers of the multivariate processes with multiple time delays. The results indicate that the proposed method consistently performs well with fast and well-balanced closed-loop time responses.

Keywords—Coefficient matching method, internal model control scheme, PID controller cascaded filter, simplified decoupler.

I. INTRODUCTION

DYNAMIC decoupling control methodologies are available for ideal decoupling, simplified decoupling, and inverted decoupling, with the choice of decoupling method depending largely on each method's advantages and restrictions [1]–[5]. Ideal decoupling provides convenient controller design, since decoupled apparent processes are systematically obtained as a diagonal matrix of processes, but it is rarely used in practice due to its complicated decoupling elements, realizability problems, and sensitivity to modeling errors. Inverted decoupling is also known as feedforward decoupling and is rarely implemented, even though it can take into account the saturation of manipulated variables. Similar to ideal decoupling, it is sensitive to modeling errors. Simplified decoupling is most widely used in industrial practice because of its robustness and simple decoupling network (i.e., its diagonal elements are set as unity). However, the decoupled apparent processes are intricate, which hinders controller tuning. Recently, there is no concrete formulation of general simplified decoupling for $n \times n$ processes beyond a case-study that was restrictively extended to 3×3 processes using an interaction compensator as a static compensator.

This work aims to derive the PID controller tuning rules for

simplified dynamic decoupling. Accordingly, decoupled apparent processes can be exactly determined from the ratio of the original open-loop transfer functions and the diagonal elements of the dynamic relative gain arrays (DRGAs) with an essential reduction technique introduced to obtain realizable decoupler elements. An effective method of PI/PID controller design is then suggested for simplified decoupling control systems, where the controllers can be directly obtained without any approximation of the decoupled apparent processes.

The proposed method's effectiveness was demonstrated through several examples of interacting multivariable processes. Simulation results showed that the proposed method consistently performed better than other existing methods.

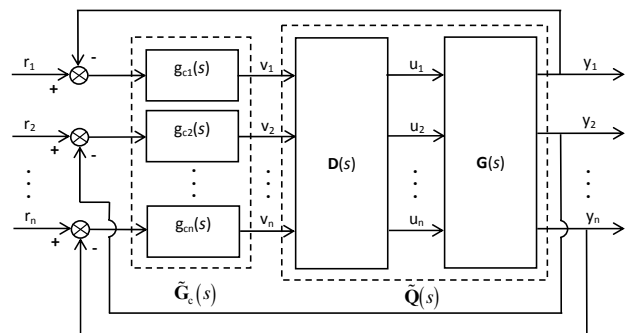

Fig. 1 Block diagram of a decoupling control system

II. PRELIMINARIES

A. Simplified Decoupling Design

Consider the block diagram of decoupling control system for a general $n \times n$ process as shown in Fig. 1, where \tilde{G}_c denotes the multi-loop controller, D represents the decoupling matrix, G and \tilde{Q} are the multivariable and decoupled apparent processes, respectively.

It is clear that the idea of decoupling is to determine a decoupling matrix D so that $GD = \tilde{Q}$ is diagonal matrix. Then, the multi-loop controller can be directly designed based on the decoupled apparent process as a set of n independent SISO processes.

$$\begin{bmatrix} g_{11} & \dots & g_{1n} \\ \vdots & \ddots & \vdots \\ g_{n1} & \dots & g_{nn} \end{bmatrix} \begin{bmatrix} d_{11} & \dots & d_{1n} \\ \vdots & \ddots & \vdots \\ d_{n1} & \dots & d_{nn} \end{bmatrix} = \begin{bmatrix} q_{11} & \dots & 0 \\ \vdots & \ddots & \vdots \\ 0 & \dots & q_{nn} \end{bmatrix} \quad (1)$$

L. Le, N.L.V. Truong and H.G. Le are with the Faculty of Mechanical Engineering, Ho Chi Minh City University of Technology and Education, Vietnam (e-mail: vuluantrn@hcmute.edu.vn, linhle@hcmute.edu.vn, gianglh@hcmute.edu.vn).

In order to design the simplified decoupling for a stable and square process with n input/outputs, all diagonal elements of decoupling matrix d_{ii} are commonly set to unity. Then, the following general form of simplified decoupler and decoupled apparent process can be respectively given by considering Truong and Lee [6]:

$$d_{ji} = \frac{C_{ij}}{C_{ii}}, \quad \forall i, j \in n; j \neq i \quad (2)$$

$$q_{ii} = \frac{g_{ii}}{\Lambda_{ii}} \quad (3)$$

where C denotes the transpose of the matrix of cofactors corresponding to the entries of \mathbf{G} , which is given as following:

$$\mathbf{C} = (\text{adj}\mathbf{G})^T = \begin{pmatrix} C_{11} & C_{21} & \cdots & C_{n1} \\ C_{12} & C_{22} & \cdots & C_{n2} \\ \vdots & \vdots & \ddots & \vdots \\ C_{1n} & C_{2n} & \cdots & C_{nn} \end{pmatrix} \quad (4)$$

Furthermore, it is evident that each diagonal element of the DRGA matrix [6]–[10] is calculated as

$$\Lambda_{ii} = \left[\mathbf{G} \otimes (\mathbf{G}^{-1})^T \right]_{ii} = g_{ii} \frac{C_{ii}}{|\mathbf{G}|} \quad (5)$$

B. Simplified Decoupling Design for the Typical Processes

Considering a TITO system as follows:

$$\mathbf{G} = \begin{bmatrix} g_{11} & g_{12} \\ g_{21} & g_{22} \end{bmatrix} \quad (6)$$

By using (2), the decoupler matrix is obtained by:

$$\mathbf{D} = \begin{bmatrix} 1 & \frac{C_{21}}{C_{22}} \\ \frac{C_{12}}{C_{11}} & 1 \end{bmatrix} \quad (7)$$

The cofactor of \mathbf{G} is easily given by

$$\mathbf{C} = (\text{adj}\mathbf{G})^T = \begin{bmatrix} C_{11} & C_{12} \\ C_{21} & C_{22} \end{bmatrix} = \begin{bmatrix} g_{22} & -g_{21} \\ -g_{12} & g_{11} \end{bmatrix} \quad (8)$$

Then, the decoupler elements can be found as:

$$d_{21} = \frac{C_{12}}{C_{11}} = -\frac{g_{21}}{g_{22}} \quad (9)$$

$$d_{12} = \frac{C_{21}}{C_{22}} = -\frac{g_{12}}{g_{11}} \quad (10)$$

According to (3), the decoupled apparent process is found as:

$$q_{11} = \frac{g_{11}}{\Lambda_{11}} = g_{11} - \frac{g_{12}g_{21}}{g_{22}} \quad (11)$$

$$q_{22} = \frac{g_{22}}{\Lambda_{22}} = g_{22} - \frac{g_{12}g_{21}}{g_{11}} \quad (12)$$

These results are exactly same with those of most approaches in the literature regarding simplified decoupling for TITO processes.

III. PID CONTROLLER DESIGN FOR THE SIMPLIFIED DECOUPLING

A. Design of Ideal Controller

For the simplified control system, diagonal PI/PID controllers $\tilde{\mathbf{G}}_c(s)$ are implemented for the decoupled apparent process, $\tilde{\mathbf{Q}}(s)$. From the standard block diagram of the decoupling control as shown in Fig. 1, the closed-loop transfer function matrix between the set points and outputs can be given as:

$$\tilde{\mathbf{H}}(s) = (\mathbf{I} + \tilde{\mathbf{Q}}(s)\tilde{\mathbf{G}}_c(s))^{-1} \tilde{\mathbf{Q}}(s)\tilde{\mathbf{G}}_c(s) = (\tilde{\mathbf{Q}}^{-1}(s)\tilde{\mathbf{G}}_c^{-1}(s) + \mathbf{I})^{-1} \quad (13)$$

Then, the resulting controller can be written by

$$\tilde{\mathbf{G}}_c(s) = \tilde{\mathbf{Q}}^{-1}(s)(\tilde{\mathbf{H}}^{-1}(s) - \mathbf{I})^{-1} \quad (14)$$

Note that the controller given by (14) is not a standard PI/PID form and it consists of two parts. i.e., $\tilde{\mathbf{Q}}^{-1}(s)$ and $(\tilde{\mathbf{H}}^{-1}(s) - \mathbf{I})^{-1}$. According to (21), the first part, $\tilde{\mathbf{Q}}^{-1}(s)$, can be written as

$$\tilde{\mathbf{Q}}^{-1}(s) = \text{diag} \left\{ \frac{\Lambda_{ii}(s)}{g_{ii}(s)} \right\} \quad (15)$$

Furthermore, $[\tilde{\mathbf{H}}^{-1}(s) - \mathbf{I}]^{-1}$ can be expressed as

$$[\tilde{\mathbf{H}}^{-1}(s) - \mathbf{I}]^{-1} = \text{diag} \left\{ \frac{h_{ii}(s)}{1 - h_{ii}(s)} \right\} \quad (16)$$

where h_{ii} is the diagonal element of $\tilde{\mathbf{H}}(s)$ that corresponds to the desired closed-loop transfer function of each loop.

Substituting (15) and (16) into (14) and rearranging it, the resulting controller is rewritten as:

$$\tilde{\mathbf{G}}_c(s) = \text{diag} \{ g_{ci}(s) \} = \text{diag} \left\{ \Lambda_{ii}(s) g_{ii}^{-1}(s) \left(\frac{h_{ii}(s)}{1 - h_{ii}(s)} \right) \right\} \quad (17)$$

According to the IMC theory [11], under the assumption of stable and causal $\Lambda_{ii}(s)$, the desired closed-loop transfer function $h_{ii}(s)$ of the i th loop is chosen as

$$h_{ii}(s) = \frac{e^{-\theta_{ii}s}}{(\lambda_i s + 1)^{m_i}} \prod_{k=1}^{q_i} \frac{z_k - s}{z_k^* + s} \quad (18)$$

where θ_{ii} , z_k , and z_k^* denote the time delay, the RHP zeros, and the corresponding complex conjugate of RHP zeros of the i th diagonal element of the process transfer function matrix, respectively. q_i is the number of the RHP zeros. The IMC filter time constant, λ_i , which is also equivalent to the closed-loop time constant, is an adjustable parameter controlling the tradeoff between the performance and robustness. m_i is the relative order of the numerator and denominator in $g_{ii}(s)$.

Substituting (18) into (17), the controller of the i th loop can be expressed by:

$$g_{ci}(s) = \Lambda_{ii}(s) g_{ii}^{-1}(s) \left(\frac{e^{-\theta_{ii}s} \prod_{k=1}^{q_i} \frac{z_k - s}{z_k^* + s}}{(\lambda_i s + 1)^{m_i} - e^{-\theta_{ii}s} \prod_{k=1}^{q_i} \frac{z_k - s}{z_k^* + s}} \right) \quad (19)$$

From (19), it is clear that the non-minimum portion of $g_{ii}(s)$ is cancelled out by the time delay and RHP zero z_k in the numerator, and thus the controller has neither causality nor stability problems.

The resulting controller obtained by (19) is not a standard PI/PID controller form. Therefore, the following Padé series expansion is utilized to obtain the PI/PID controller:

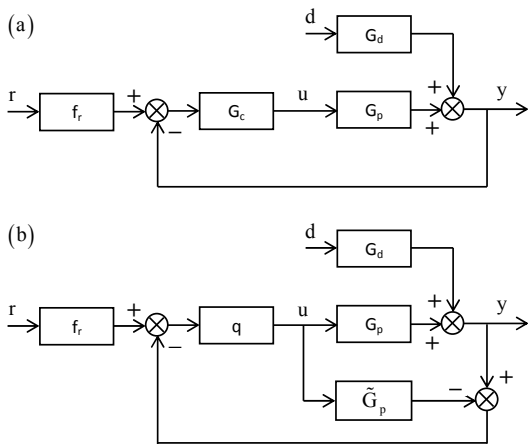

Fig. 2 Block diagram of feedback control strategies (a) Classical feedback control (b) IMC

B. Design of IMC-PID Cascaded with Filter

According to the standard block diagram of the feedback control system as shown in Fig. 1, where $G_p(s)$, $\tilde{G}_p(s)$,

$G_c(s)$, $q(s)$, and $f_r(s)$ denote the process, the process model, the equivalent feedback controller, the IMC controller, and the set-point filter, respectively. Assume that $y(s)$, $r(s)$, $d(s)$, and $u(s)$ correspond to the controlled output, set-point input, disturbance input, and the manipulated variables. If there is no model error (i.e., $G_p(s) = \tilde{G}_p(s)$), then the set-point and disturbance responses in the IMC control structure can be simplified as:

$$y(s) = G_p(s)q(s)f_r(s)r(s) + [1 - \tilde{G}_p(s)q(s)]G_d(s)d(s) \quad (20)$$

In accordance with the IMC parameterization [11], the process model $\tilde{G}_p(s)$ is factored into two parts:

$$\tilde{G}_p(s) = p_m(s)p_A(s) \quad (21)$$

where $p_m(s)$ is the portion of the model inverted by the controller (minimum phase), $p_A(s)$ is the portion of the model not inverted by the controller (it is the non-minimum phase that may be included the dead time and/or right half plane zeros and chosen to be all-pass), and the requirement that $p_A(0) = 1$ is necessary for the controlled variable to track its set-point.

The IMC controller $q(s)$ can be designed as:

$$q(s) = p_m^{-1}(s)f(s) \quad (22)$$

For the 2DOF control structure, the IMC filter $f(s)$ is chosen for enhanced performance as:

$$f(s) = \frac{\sum_{i=1}^m \beta_i s^i + 1}{(\lambda s + 1)^n} \quad (23)$$

where λ is an adjustable parameter, which can be utilized for the tradeoffs between the performance and robustness. The integer n is selected to be large enough for the IMC controller proper. The parameter β_i is determined to cancel the poles near zero in $G_d(s)$.

$$\left. \frac{1 - G_p(s)q(s)}{1 - \frac{p_A(s)(\sum_{i=1}^m \beta_i s^i + 1)}{(\lambda s + 1)^n}} \right|_{s=z_{d1}, z_{d2}, \dots, z_{dm}} = 0 \quad (24)$$

Substituting (23) into (22), the IMC controller is obtained by

$$q(s) = p_m^{-1}(s) \frac{(\sum_{i=1}^m \beta_i s^i + 1)}{(\lambda s + 1)^n} \quad (25)$$

Substituting (25) into (20), the closed-loop transfer functions for the desired set-point and disturbance responses are respectively simplified as:

$$\frac{y(s)}{r(s)} = \frac{p_A(s) (\sum_{i=1}^m \beta_i s^i + 1)}{(\lambda s + 1)^n} \quad (26)$$

$$\frac{y(s)}{d(s)} = \left[1 - \frac{p_A(s) (\sum_{i=1}^m \beta_i s^i + 1)}{(\lambda s + 1)^n} \right] G_d(s) \quad (27)$$

The ideal feedback controller $G_c(s)$ that yields the desired loop responses given by (26) and (27) can be constituted by

$$G_c(s) = \frac{q(s)}{1 - \tilde{G}_p(s)q(s)} \quad (28)$$

Therefore, the ideal feedback controller for achieving the desired loop response can be easily obtained by

$$G_c(s) = \frac{p_m^{-1}(s) (\sum_{i=1}^m \beta_i s^i + 1)}{(\lambda s + 1)^n - p_A(s) (\sum_{i=1}^m \beta_i s^i + 1)} \quad (29)$$

It is indicated from (29) that the numerator expression $(\sum_{i=1}^m \beta_i s^i + 1)$ may cause an unreasonable overshoot in the servo response. To overcome this problem, we can design the suitable set-point filter. Moreover, the resulting controller given by (29) does not have the standard PID form despite that it is physically realizable. Consequently, it is necessary to convert it into the PID form more closely by using some clever approximation techniques, such as the expression of time-delay part with the low-order Padé approximation used by a number of authors [11], [12]. In this paper, we also utilize the low-order Padé approximation in the different manner with previous design methods in terms of the most closely controller approximates the equivalent feedback controller.

C. IMC-PID Tuning Rules

The FOPDT process model is one of the most widely used models in the process industries, which is usually considered to design the PID controller. The process transfer function is given as:

$$G_p(s) = \frac{K e^{-\theta s}}{\tau s + 1} \quad (30)$$

where K , τ , and θ represent the process gain, the time constant, and the time delay, respectively.

For the 2DOF control structure, the IMC filter is reasonable to design as following form:

$$f(s) = \frac{\beta s + 1}{(\lambda s + 1)^2} \quad (31)$$

Accordingly, the ideal feedback controller is found as

$$G_c(s) = \frac{(\tau s + 1)(\beta s + 1)}{K \left[(\lambda s + 1)^2 - e^{-\theta s} (\beta s + 1) \right]} \quad (32)$$

Noted that the approximation of the dead-time term $e^{-\theta s}$ in the denominator by a 3/2 Padé expansion. By comparing the resulting controller obtained by (32) and the PID controller in cascaded with the filter that is given by (33).

$$G_c(s) = K_c \left(1 + \frac{1}{\tau_I s} + \tau_D s \right) \left(\frac{1 + cs + ds^2}{1 + as + bs^2} \right) \quad (33)$$

Finally, the analytical tuning rules of the proportional, integral, and derivative terms of the proposed PID controller can be compactly obtained as

$$K_c = \frac{\left(\frac{2\theta}{5} \right)}{K(2\lambda + \theta - \beta)} \quad (34)$$

$$\tau_I = \frac{2\theta}{5} \quad (35)$$

$$\tau_D = \frac{\theta}{8} \quad (36)$$

The value of the extra degree of freedom β is determined for neglecting the open-loop pole at $s = -1/\tau$. According to (5), the value of β can be found as

$$\beta = \tau \left[1 - \left(1 - \frac{\lambda}{\tau} \right)^2 e^{-\theta/\tau} \right] \quad (37)$$

The filter parameters in (33) can be easily found as

$$a = \frac{\left(\frac{3\theta\beta}{5} - \frac{\theta^2}{10} + \frac{4\lambda\theta}{5} + \lambda^2 \right)}{(2\lambda + \theta - \beta)} - \tau \quad (38)$$

$$b = \frac{\left(-\frac{3\theta^2\beta}{20} + \frac{\theta^3}{60} + \frac{\lambda\theta^2}{10} + \frac{2\lambda^2\theta}{5} \right)}{(2\lambda + \theta - \beta)} - a\tau \quad (39)$$

$$c = \beta \quad (40)$$

$$d = 0 \quad (41)$$

As mentioned from (29), the lead term $(\beta s + 1)$ can cause excessive overshoot in the set-point response, which can be eradicated by adding the set-point filter f_r as:

$$f_r(s) = \frac{\gamma\beta s + 1}{\beta s + 1} \quad (42)$$

where $0 \leq \gamma \leq 1$.

Some important remarks can be described as:

- $\gamma = 0$. For this extreme case, there is no lead term in the set-point filter, which can cause a slow servo response.
- $\gamma = 1$. For this case, there is no set-point filter.
- $0 < \gamma < 1$. That means we adjust γ online to obtain the desired speed of the set-point response.

IV. SIMULATION STUDY

In this section, two examples are considered to demonstrate the advanced performance of the proposed method. To guarantee a fair comparison, the performance and robustness of the decoupling control system are measured by the following evaluation criteria.

A. Integral Absolute Error Index

To evaluate the closed-loop performance, the integral absolute error (IAE) criterion is considered, which is defined as [13]:

$$IAE = \int_0^T |e(t)| dt \quad (43)$$

where $e(t) = r(t) - y(t)$. T is a finite time which is chosen for the integral approach steady-state value.

B. Total Variation (TV)

To evaluate the magnitude of the manipulated input usage, the total up and down movement of the control signal is considered as [13]:

$$TV = \sum_{k=1}^T |u(k+1) - u(k)| \quad (44)$$

TV is a good measure of the smoothness of controller output and should be small.

C. Case Study

In this work, the Wood and Berry (WB) column [14], a pilot-scale distillation column consisting of an eight-tray plus re-boiler separating methanol and water, is considered. The open-loop transfer function matrix is given by

$$\mathbf{G}(s) = \begin{bmatrix} \frac{12.8e^{-s}}{16.7s + 1} & \frac{-18.9e^{-3s}}{21s + 1} \\ \frac{6.6e^{-7s}}{10.9s + 1} & \frac{-19.4e^{-3s}}{14.4s + 1} \end{bmatrix} \quad (45)$$

By using (7), the simplified decoupling matrix is obtained by

$$\mathbf{D}(s) = \begin{bmatrix} 1 & \frac{1.477(16.70s + 1)e^{-2s}}{21s + 1} \\ \frac{0.34(14.4s + 1)e^{-4s}}{10.9s + 1} & 1 \end{bmatrix} \quad (46)$$

The SAT [15] and BLT [16] design methods are employed here for the comparison.

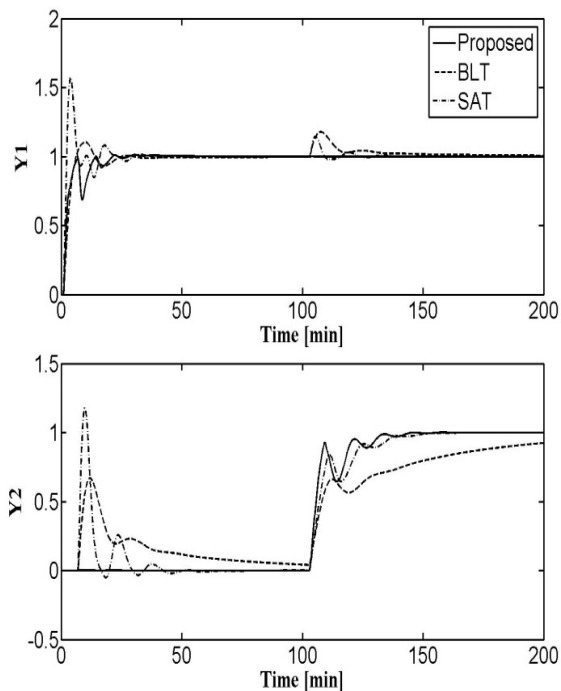

Fig. 3 Closed-loop responses to the sequential step changes in the set-point for the WB column

For the proposed method, a set of the adjustable parameters λ_i are suggested to achieve a desirable specification of robust stability and performance by increasing them monotonously. Therefore, the closed-loop time constant values λ_i are obtained as 5.26 and 8.00 for loops 1 and 2, respectively.

The resulting controller parameters and performance indices calculated using the above-mentioned methods are also listed in Table I. Fig. 3 compares the closed-loop time responses by the proposed method and the above-mentioned design methods, where the unit step changes in the set-point are sequentially made at $t = 0$ and $t = 80$ to the 1st and 2nd loops, respectively. It is clear from Fig. 3 that the proposed design

method provides a good performance with fast and well-balanced responses in comparison with those of the existing methods. Besides, the effectiveness of the proposed design method is also confirmed by its smallest IAE value in Table I.

TABLE I
CONTROLLER PARAMETERS AND RESULTING PERFORMANCE INDICES FOR THE
WB COLUMN

Controller parameters	Proposed	BLT	SAT
K_c	0.035, -0.015	0.38, -0.075	0.87, -0.09
τ_i	0.653, 1.200	8.29, 23.60	3.25, 10.40
τ_d	0.204, 0.375	-	-
a	0.369, 0.702	-	-
b	0.103, 0.351	-	-
c	9.194, 10.67	-	-
d	0, 0	-	-
γ	0.900, 0.80	-	-
λ	5.260, 8.00	-	-
TV	2.55	6.22	4.24
IAE	11.15	57.99	22.6

V. CONCLUSION

A generalized approach of the simplified decoupling technique is effectively for improving the overall performance of a multivariable control system. Since it is proved that the simplified decoupler element is compactly formulated as a ratio of the cofactor of open-loop transfer function matrix of multivariable process to its diagonal element. Moreover, the decoupled apparent process is also easily found as a ratio of the diagonal original open-loop transfer function to the diagonal element of DRGA. Therefore, the proposed IMC-PID controller cascaded with filter PI/PID can be directly utilized for the simplified decoupling system.

The simulations were conducted by tuning various controllers for the multivariable processes with multiple time delays. The results indicate that the proposed method consistently affords a good performance with a fast and well-balanced closed-loop time response.

ACKNOWLEDGMENT

This work was supported by the HCM City University of Technology and Education (HCMUTE), Vietnam.

REFERENCES

- [1] E. Gagnon, A. Pomerleau, and A. Desbiens, "Simplified, ideal or inverted decoupling," *ISA Trans.*, vol. 37, no. 1, pp. 265-276, 1998.
- [2] K. Weischedel, T.J. McAvoy, "Feasibility of decoupling in conventional controlled distillation column," *I&EC Fundam.*, vol. 19, no. 4, pp. 379-384, 1980.
- [3] T. J. McAvoy, *Interaction Analysis: Principles and Applications*. NC, USA: Instrument Society of America, Research Triangle Park, 1983.
- [4] F. G. Shinskey, *Process Control system: Application, Design and Adjustment*. NY, USA: McGraw-Hill, 1988.
- [5] D. E. Seborg, T. F. Edgar, and D. A. Mellichamp, *Process Dynamics and Control*. NY, USA: John Wiley & Sons, 1989.
- [6] N. L. V. Truong and M. Lee, "Independent design of multi-loop PI/PID controllers for interacting multivariable processes," *J. Process Control*, vol. 20, pp. 922-933, 2010.
- [7] M. F. Witcher and T. J. McAvoy, "Interacting control systems: steady-state and dynamic measurement of interaction," *ISA Trans.*, vol. 16, pp. 35-41, 1977.
- [8] E. H. Bristol, "Recent results on interactions in multivariable process control," in *Proceedings of the 71st Annual AIChE Meeting*, Houston, TX, USA, 1979.
- [9] L. S. Tung and T. F. Edgar, "Analysis of control-output interaction in dynamic systems," *AIChE J.*, vol. 27, pp. 690-693, 1981.
- [10] S. Skogestad and I. Poslethwaite, *Multivariable Feedback Control*. NY, USA: John Wiley and Sons, 1996.
- [11] M. Morari and E. Zafiriou, *Robust Process Control*. NJ, USA: Englewood Cliffs, Prentice Hall, 1989.
- [12] T. H. Owen and C. S. Orville, *Computation Methods in Chemical Engineering*. NJ, USA: Prentice Hall PTR, 1996.
- [13] S.L. William, *Control System Fundamentals*. London, UK: CRC Press, 1999.
- [14] R. K. Wood and M.W. Berry, "Terminal composition control of binary distillation column," *Chem. Eng. Sci.*, vol. 28, pp. 1707-1717, 1973.
- [15] A. P. Loh, C. C. Hang, C. K. Quek, and V. N. Vasnani, "Autotuning of multivariable proportional-integral controllers using relay feedback," *Ind. Eng. Chem. Res.*, vol. 32, pp. 1002-1007, 1993.
- [16] W. L. Luyben, "Simple method for tuning SISO controllers in multivariable systems," *Ind. Eng. Chem. Process Des. Dev.*, vol. 25, pp. 654-660, 1986.