

3-D Visualization and Optimization for SISO Linear Systems Using Parametrization of Two-Stage Compensator Design

Kazuyoshi Mori, Keisuke Hashimoto

Abstract—In this paper, we consider the two-stage compensator designs of SISO plants. As an investigation of the characteristics of the two-stage compensator designs, which is not well investigated yet, of SISO plants, we implement three dimensional visualization systems of output signals and optimization system for SISO plants by the parametrization of stabilizing controllers based on the two-stage compensator design. The system runs on Mathematica by using “Three Dimensional Surface Plots,” so that the visualization can be interactively manipulated by users. In this paper, we use the discrete-time LTI system model. Even so, our approach is the factorization approach, so that the result can be applied to many linear models.

Keywords—Linear systems, visualization, optimization, two-Stage compensator design, Mathematica.

I. INTRODUCTION

IN this paper, we consider the two-stage compensator designs of SISO plants in the framework of the factorization approach. In the design, during the first stage, a new closed loop system selects stabilizing compensator for the plant. In the second stage, a stabilizing controller is selected for the new closed-loop system that also achieves some other design objectives such as decoupling and sensitive minimization.

Recently, we have given a parametrization of stabilizing controllers of the two stage compensator design based only on the factorization approach, which is in the form of the Youla-Kučera-parametrization [1], [12]-[14].

The factorization approach to control systems has the advantage that embraces, within a single framework, numerous linear systems such as continuous-time as well as discrete-time systems, lumped as well as distributed systems, one-dimensional as well as multidimensional systems, etc [1]-[3]. Hence, the result given in this paper will be able to a number of models in addition to the multidimensional systems. In the factorization approach, when problems such as feedback stabilization are studied, one can focus on the key aspects of the problem under study rather than be distracted by the special features of a particular class of linear systems. This approach leads to conceptually simple and computationally tractable solutions to many important and interesting problems [4]. A transfer matrix of this approach is considered as the ratio of two stable causal transfer matrices.

K. Mori is School of Computer Science and Engineering, The University of Aizu, Aizu-Wakamatsu 965-8580, Japan (e-mail: kazuyoshi.mori@ieee.org).

K. Hashimoto is School of Computer Science and Engineering, The University of Aizu, Aizu-Wakamatsu 965-8580, Japan.



Fig. 1 Earthquake-Resistant Dumpers for Building

In some design problems, one uses a so-called *two-stage compensator design* for selecting an appropriate stabilizing compensator. One of examples of two-stage compensator design is earthquake-resistant dumpers for a building shown in Fig. 1. Another example of two-stage compensator design is earthquake-resistant dumpers for a bridge shown in Fig. 2. By attaching resistant dumpers to these building and bridge, these building and bridge become strong against earthquake.

The problem of the two-stage compensator design is that the relationship between inputs and outputs are not theoretically clarified yet. Thus, we consider to make a software to present the relationship. Thus, the objective of this paper is to make systems to visualize the input-output relationship based on the two-stage compensator design. The systems are implemented on Mathematica [9]-[11], one of the most common computer algebra systems. By using visualization technique and Golden Section Method [15], we also consider the optimization of the system based on

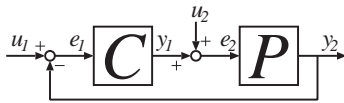

Fig. 2 Earthquake-Resistant Dumpers for Bridge

 Fig. 3 Feedback System Σ .

the two-stage compensator design. To achieve this, we have implemented visualization systems of the parametrization of stabilizing controllers based on the two-stage compensator designs [16]-[18] and also implemented system, which present norms of output signals and optimize the system based on the two-stage compensator design. We call these system Visualization system and Optimization system, respectively.

In Visualization system, output signals can be visualized as 3D graphs. Because we use Mathematica, we can overlook output signal with all parameter by using some implemented functions of 3D graph system such as we can rotate 3D graph by dragging the mouse inside the graphic. In Optimization systems, norms of output signals can be visualized 3D graphs and minimum norm of output signals can be found by Golden Section Method [15].

In this paper, we consider the SISO discrete-time LTI systems as a model of the factorization approach.

II. PRELIMINARY

The stabilization problem considered in this paper follows the papers [6], [7], in which the feedback system Σ [4] is as in Fig. 3. For further details the reader is referred to the literature [4], [6]-[8].

We consider that the set of stable causal transfer functions is an integral domain, denoted by \mathcal{A} . The total ring of fractions of \mathcal{A} is denoted by \mathcal{F} ; that is, $\mathcal{F} = \{n/d \mid n, d \in \mathcal{A}, d \neq 0\}$. This \mathcal{F} is considered as the set of all possible transfer functions, which is given as ratio of two stable causal transfer functions. Matrices over \mathcal{F} are transfer matrices. Let \mathcal{Z} be a prime ideal of \mathcal{A} with $\mathcal{Z} \neq \mathcal{A}$. From these we construct the set \mathcal{P} of proper transfer functions, the set \mathcal{P}_s of strictly proper functions. The reader can be found their definition in [5].

In this paper, we consider the discrete-time LTI system, then

$$\mathcal{A} = \left\{ \frac{u}{v} \mid u, v \in \mathbb{R}[d], \text{ all roots } r \text{ of } v \text{ are with } |r| > 1 \right\},$$

$$\mathcal{Z} = (d),$$

d is the unit delay operator.

Throughout the paper, we consider principally single-input single-output plants, and its transfer function, which is also called a *plant* itself simply. Even so, we will investigate multi-input multi-output plants as possible as we can. The plant is denoted by P and belongs to $\mathcal{P}^{n \times m}$, which means that the plant has m inputs and n outputs. We can always represent P in the form of a fraction $P = ND^{-1}$, where $N \in \mathcal{A}^{n \times m}$ and $D \in \mathcal{A}^{m \times m}$ with nonsingular.

The reader can found the notion of stabilization of P by C in [5]. In [5], a transfer matrix $H(P, C) \in \mathcal{F}^{(m+n) \times (m+n)}$ is defined as follows:

$$H(P, C) := \begin{bmatrix} (I_n + PC)^{-1} & -P(I_m + PC)^{-1} \\ C(I_n + PC)^{-1} & (I_m + PC)^{-1} \end{bmatrix} \quad (1)$$

provided that $I_n + PC$ is a nonzero of \mathcal{A} . This $H(P, C)$ is the transfer matrix from $[u_1^t \ u_2^t]^t$ to $[e_1^t \ e_2^t]^t$ of the feedback system Σ . For the notions of “*stabilizable*” and “*stabilizing controller*”, the reader should refer to [5]. We will denote by $\mathcal{S}(P)$ the set of stabilizing controllers of P .

The following is well known Youla-Kučera-parametrization (Theorem 1) to provide the set of all stabilizing controllers.

Theorem 1: ([1], [12]-[14]) Let P denote a causal plant of $\mathcal{P}^{n \times m}$. Let $P = ND^{-1} = \tilde{D}^{-1}\tilde{N}$. Select \tilde{X}, \tilde{Y}, X and Y such that

$$\tilde{Y}N + \tilde{X}D = I_m, \quad \tilde{N}Y + \tilde{D}X = I_n. \quad (2)$$

Then the $\mathcal{S}(P)$ is given by

$$\mathcal{S}(P) = \{(\tilde{X} - R\tilde{N})^{-1}(\tilde{Y} + R\tilde{D}) \mid R \in \mathcal{A}^{m \times n}, |\tilde{X} - R\tilde{N}| \neq 0\}$$

$$= \{(Y + RD)(X - NR)^{-1} \mid R \in \mathcal{A}^{m \times n}, |X - NR| \neq 0\},$$

where R is a parameter matrix.

III. TWO-STAGE COMPENSATOR DESIGN

The two-stage compensator design is for selecting an appropriate stabilizing compensator [4]. Given a plant P , the first stage consists of selecting a stabilizing compensator for P . Let $C_0 \in \mathcal{S}(P)$ denote a compensator of P (that is, an arbitrary but fixed compensator of P) and define $P_1 = P(I_m + C_0P)^{-1}$. The second stage consists of selecting a stabilizing controller for P_1 that also achieves some other design objectives such as decoupling, sensitivity minimization,

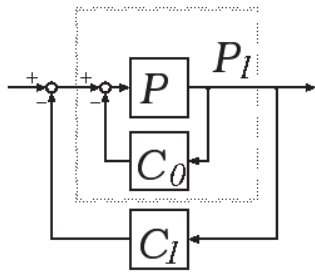

Fig. 4 Two-Stage Compensator Design (y_2 to u_2)

etc. The resulting configuration with its inner and outer loops is shown in Fig. 4.

Theorem 2 is same as Theorem 5.3.10 of [4]. Theorem 3 is a generalized version of Theorem 2 with coprime factorizability. We will employ following theorems and corollary to achieve two stage compensator design.

Theorem 2: ([5]) Let P denote a causal plant of $\mathcal{P}^{m \times n}$ and C_0 a causal stabilizing controller of P ($C_0 \in \mathcal{P}^{m \times n}$). Further let P_1 be $P(I_m + C_0P)^{-1}$. Denote by $C_0 + \mathcal{S}(P_1)$ the following set:

$$\{C_0 + C_1 \mid C_1 \in \mathcal{S}(P_1)\}.$$

Then

$$C_0 + \mathcal{S}(P_1) \subset \mathcal{S}(P), \quad (3)$$

with equality holding if and only if $C_0 \in \mathcal{A}^{m \times n}$.

Fig. 4 cannot implement all controllers as the stabilizing controllers in general.

Theorem 3: ([5]) Let P, C_0, P_1 be as in Theorem 2.

Let $N, D, \tilde{N}, \tilde{D}, Y, X, \tilde{Y}, \tilde{X}$ be matrices over A such that

$$\begin{cases} P = ND^{-1} = \tilde{D}^{-1}\tilde{N}, & C_0 = YX^{-1} = \tilde{X}^{-1}\tilde{Y}, \\ \tilde{Y}N + \tilde{X}D = I_m, & \tilde{N}Y + \tilde{D}X = I_n. \end{cases}$$

Then,

$$\begin{aligned} C_0 + \mathcal{S}(P_1) &= \{(\tilde{X} - R\tilde{N})^{-1}(\tilde{Y} + R\tilde{D}) \mid R = \tilde{X}R_1X, R_1 \in \mathcal{A}^{m \times n}\} \\ &= \{(Y + RD)(X - NR)^{-1} \mid R = \tilde{X}R_1X, R_1 \in \mathcal{A}^{m \times n}\}. \end{aligned}$$

We can obtain Theorem 3 by replacing parameter R of Theorem 1 with $\tilde{X}R_1X$.

The stabilizing controller C_0 is originally a stabilizing controller of P . As well from Theorem 2, whose original is appeared in [4], the sum of C_0 and a stabilizing controller of P_1 . Letting C_1 be a stabilizing controller of P , then $C_0 + C_1$, which is parallelly allocated as in Fig. 5, is still a stabilizing controller.

The theorems were based on the feedback from y_2 to u_2 (cf. Figs. 3 and 4). Even so, we note that, from Fig. 3, we have two inputs u_1 and u_2 and two outputs y_1 and y_2 . Thus we can consider alternative two-stage compensator design based on other input(s) and other output(s). Let us consider the two-stage compensator design based on the feedback from y_1 to u_1 . In this case, the feedback system is as in Fig. 6.

The configuration is as in Fig. 7. Based on this feedback, the following result has also been given in [5].

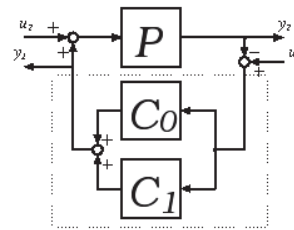

Fig. 5 Composite Stabilized Feedback with c_0 and c_1

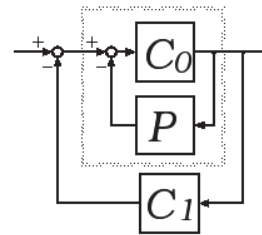

Fig. 6 Feedback from y_1 to u_1

Corollary 1: ([5]) Let P, C_0, P_1 be as in Theorem 2. Let $N, D, \tilde{N}, \tilde{D}, Y, X, \tilde{Y}, \tilde{X}$ be as in Theorem 3.

Then we have,

$$\begin{aligned} C_0 + \mathcal{S}(P_1) &= \{(\tilde{X} - R\tilde{N})^{-1}(\tilde{Y} + R\tilde{D}) \mid \\ &R = -\tilde{Y}R_2Y, R_2 \in \mathcal{A}^{n \times m}, |\tilde{X} - R\tilde{N}| \neq 0\} \\ &= \{(Y + RD)(X - NR)^{-1} \mid \\ &R = -\tilde{Y}R_2Y, R_2 \in \mathcal{A}^{n \times m}, |X - NR| \neq 0\}. \end{aligned}$$

We can obtain Corollary 1 by replacing parameter R of Theorem 1 with $\tilde{Y}R_2Y$ where R_2 of Corollary 1 is equal to R of Theorem 1.

IV. DEMONSTRATION

As an example, we consider P as:

$$P = \frac{d^2 + 1}{3d^2 - 2d + 1},$$

and the inputs u_1 and u_2 be 0 and 1, respectively, where d denotes the delay operator. In this case, the coprime

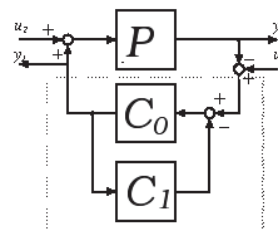

Fig. 7 Composite Stabilized Feedback with c_0 and c_1 based on Feedback from y_1 to u_1

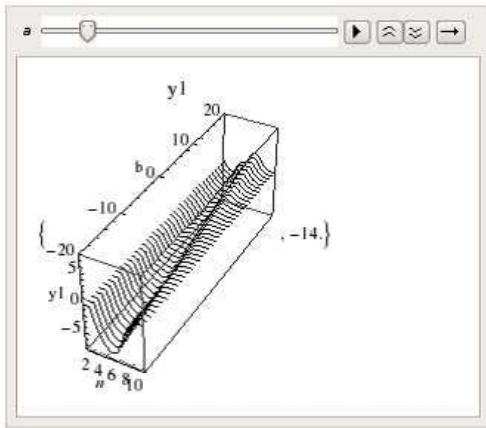

Fig. 8 3D Graph Animation of Output Signal y_1 based on Theorem 3. R_1 form is $a + bd$. a and b range are $-20 \leq a, b \leq 20$

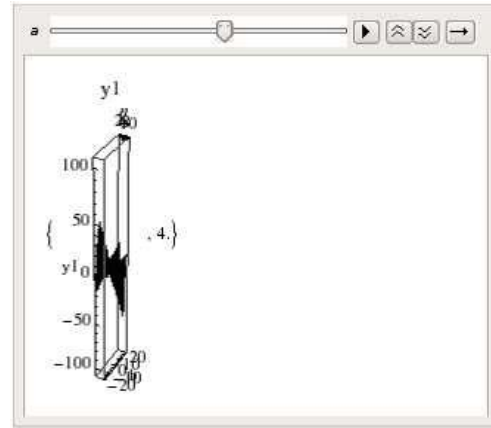

Fig. 10 3D Graph Animation of Output Signal y_1 based on Corollary 1. R_2 form is $a + bd$. a and b range are $-20 \leq a, b \leq 20$

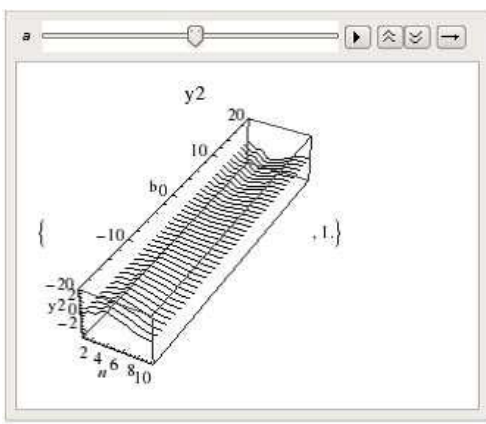

Fig. 9 3D Graph Animation of Output Signal y_2 based on Theorem 3. R_1 form is $a + bd$. a and b range are $-20 \leq a, b \leq 20$

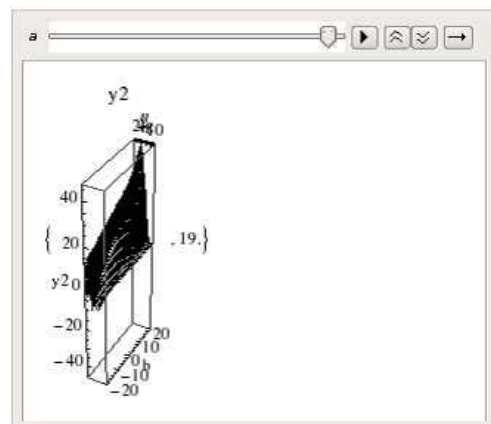

Fig. 11 3D Graph Animation of Output Signal y_2 based on Corollary 1. R_2 form is $a + bd$. a and b range are $-20 \leq a, b \leq 20$

factorization is given as

$$N = \tilde{N} = \frac{1}{5}(d^2 + 1), \quad D = \tilde{D} = -\frac{1}{5}(2 + 1)(3d - 1),$$

$$Y = \tilde{Y} = 4 + \frac{3d}{2}, \quad X = \tilde{X} = -\frac{2 + d}{2}.$$

We consider two constants a and b and the form $a + bd$ as a parameter. The visualization is based on “Three Dimensional Surface Plots” of Mathematica [10], [11].

Let $-20 \leq a, b \leq 20$, $R_1 = a + bd$, $u_1 = 0$, and $u_2 = 1$. Then outputs y_1 and y_2 based on Theorem 3 are visualized as Figs. 8 and 9, respectively. Also outputs y_1 and y_2 based on Corollary 1 are visualized as Figs. 10 and 11, respectively. In this visualization, the constant a is implemented by Slider Function of Mathematica. On the other hand, the constant b is one of three axes. Thus the figure changed by time (the value of the constant a), so that they are animations on Mathematica.

Next, we consider l_2 -norms of signals. Again let $-20 \leq a, b \leq 20$, $R_1 = a + bd$, $u_1 = 0$, and $u_2 = 1$. Then the norms of y_1 and y_2 based on Theorem 3 are visualized as Figs. 12 and 13, respectively. Also the norms of y_1 and y_2 based on Corollary 1 are visualized as Figs. 14 and 15, respectively.

Minimum norms based on Golden Section Method [15] are shown in Table I.

V. CONCLUSION AND FUTURE WORKS

In this paper, we have visualized the output signals for discrete-time LTI systems using parametrization of two-stage compensator design. Our approach is the factorization approach, so that the result can be also applied to many other linear models. We also visualize the norms of the outputs and obtained the optimization by using the golden section method.

The optimization by golden section method is to obtain the minimal or maximal values numerically, which is not theoretical. We will investigate alternative methods to obtain the optimal values by theoretical methods.

TABLE I
MINIMUM NORM OF FIGS. 12 - 15

Figure	Minimum norm
Fig. 12	1.08397
Fig. 13	0.122474
Fig. 14	1.2083
Fig. 15	0.316228

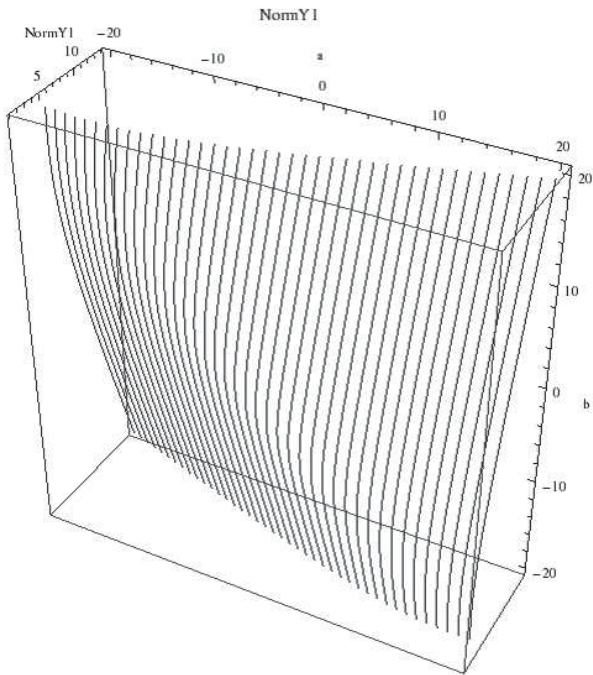

Fig. 12 Norms of Output Signal y_1 based on Theorem 3. R_1 form is $a + bd$. a and b range are $-20 \leq a, b \leq 20$

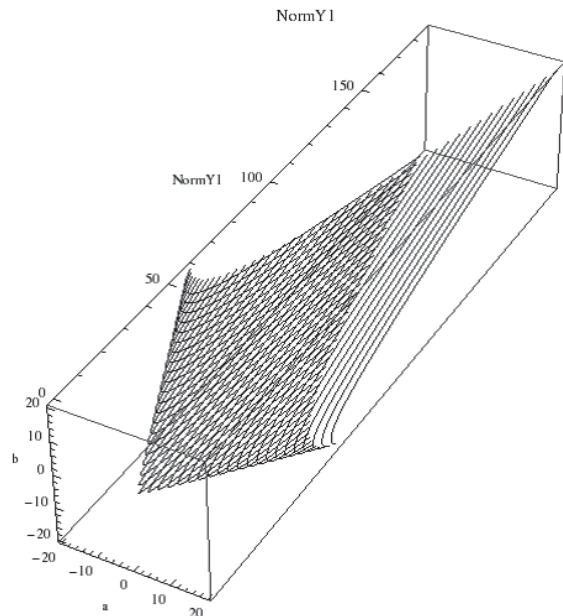

Fig. 14 Norms of Output Signal y_1 based on Corollary 1. R_2 form is $a + bd$. a and b range are $-20 \leq a, b \leq 20$

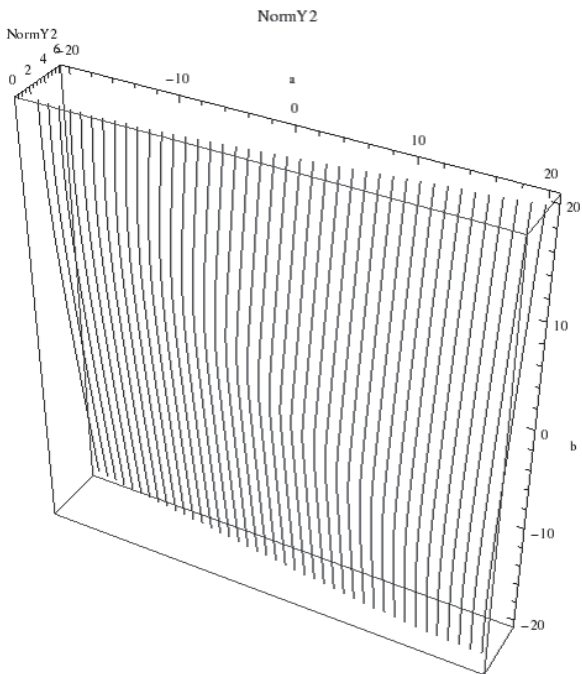

Fig. 13 Norms of Output Signal y_2 based on Theorem 3. R_1 form is $a + bd$. a and b range are $-20 \leq a, b \leq 20$

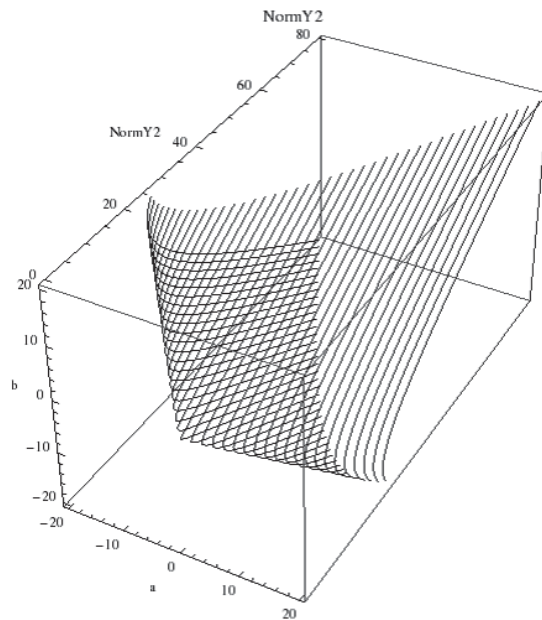

Fig. 15 Norms of Output Signal y_2 based on Corollary 1. R_2 form is $a + bd$. a and b range are $-20 \leq a, b \leq 20$

REFERENCES

- [1] C. A. Desoer, R. W. Liu, J. Murray, and R. Saeks, "Feedback system design: The fractional representation approach to analysis and synthesis," *IEEE Trans. Automat. Contr.*, vol. AC-25, pp. 399-412, 1980.
- [2] M. Vidyasagar, H. Schneider, and B. A. Francis, "Algebraic and topological aspects of feedback stabilization," *IEEE Trans. Automat. Contr.*, vol. AC-27, pp. 880-894, 1982.
- [3] K. Mori, "Parametrization of all strictly causal stabilizing controllers," *IEEE Trans. Automat. Contr.*, vol. AC-54, pp.2211-2215, 2009.
- [4] M. Vidyasagar, *Control System Synthesis: A Factorization Approach*, Cambridge, MA:MIT Press, 1985.
- [5] K. Mori, "Multi-stage compensator design -a factorization approach-," in *Proceedings of The 8th Asian Control Conference(ASCC 2011)*, 2011, 1012-1017.
- [6] V. R .Sule, "Feedback stabilization over commutative rings: The matrix case," *SIAM J. Control and Optim.*, vol. 32, no. 6, pp. 1675-1695, 1994.
- [7] K. Mori and K. Abe, "Feedback stabilization over commutative rings: Further study of coordinate-free approach," *SIAM J. Control and Optim.*, vol. 39, no. 6, pp. 1952-1973, 2001.
- [8] S. Shankar and V. R.Sule, "Algebraic geometric aspects of feedback stabilization," *SIAM J. Control and Optim.*, vol. 30, no. 1, pp. 11-30, 1992.
- [9] P. Wellin, *Programming with Mathematica:An Introduction*, Cambridge University Press, 2013.
- [10] ThreeDimensionalSurfacePlots: URL: <http://reference.wolfram.com/mathematica/tutorial/ThreeDimensionalSurfacePlots.en.html>
- [11] S. Wolfram, "The Mathematica Book Forth Edition,"*Wolfram Research, Inc.*
- [12] F. A. Aliev and V. B. Schneider, "Comments on Optimizing Simultaneously Over the Numerator and Denominator Polynomials in the Youla-Kucera Parameterization" *IEEE Trans. Automat. Contr.*, vol. 52, no. 4 pp. 763, 2007.
- [13] D. C. Youla, H. A. Jabr. and J. J. Bongiorno, "Modern Wiener-Hopf design of optimal controllers Part II: The multivariable case," *IEEE Trans. Automat. Contr.*, vol. AC-21, no. 3 pp. 319-338, Jun. 1976.
- [14] V. Kučela, "Stability of discrete linear control systems," *Preprints 6th IFAC World Congr.*, Boston, MA, 1975.
- [15] W. H. Press, S. A. Teukolsky, W. T. Vetterling and B. P. Flannery, "Numerical Recipes Third Edition: Golden Section Search in One Dimension," *Cambridge university*, pp. 492-495, 2007.
- [16] K. Hashimoto and K. Mori, "Visualization Input-Output Relation with Parametrization of Two Stage Compensator Design", *The Society of Instrument and Control Engineers Tohoku Chapter.*, Japan, Fukushima, no. 284-7, Nov. 2013.
- [17] K. Hashimoto and K. Mori, "Visualization of The Input-Output Relation of Multi-Input Multi-Output System Using Parametrization of Two-Stage Compensator Design", *Tohoku-Section Joint Convention of Institutes of Electrical and information Engineers.*, Japan, Yamagata, no. 2F01, Aug. 2013.
- [18] K. Hashimoto and K. Mori, "Visualization Of The Input-output Relation Of Single-input Single-output System And Multi-input Multi-output System Using Parametrization Of Two-stage Compensator Design", *34th International Association of Science and Technology for Development Conference on Modelling, Identification and Control MIC 2015*, Austria, Innsbruck, no. 826-032, Feb. 2015.