

Effect of Soil Corrosion in Failures of Buried Gas Pipelines

Saima Ali, Pathamanathan Rajeev, Imteaz A. Monzur

Abstract—In this paper, a brief review of the corrosion mechanism in buried pipe and modes of failure is provided together with the available corrosion models. Moreover, the sensitivity analysis is performed to understand the influence of corrosion model parameters on the remaining life estimation. Further, the probabilistic analysis is performed to propagate the uncertainty in the corrosion model on the estimation of the remaining life of the pipe. Finally, the comparison among the corrosion models on the basis of the remaining life estimation will be provided to improve the renewal plan.

Keywords—Corrosion, pit depth, sensitivity analysis, exposure period.

I. INTRODUCTION

SOIL corrosion initiates in buried cast iron pipe as it remains in contact with the surrounding soil. The soil corrosivity is influenced by several factors like level of “aeration”, “water retention”, “dissolved salt content”, “soil resistivity”, “acidity” and “presence of ionic species”. Aeration decreases the probability of corrosion by maintaining the environment dry whereas water retention in the soil accelerates soil corrosion. Similarly, dissolved salt content increases soil corrosion due to the higher conductivity of the dissolved soil. On the other hand, soil resistivity reduces soil corrosion rate by resisting current flow through the soil. In acidic environment soil corrosivity is increases and in the same way presence of ionic species also increases the rate of soil corrosion.

Over the last few years, several failures in the transmission and distribution gas pipelines have been reported around the world. Soil corrosion has a significant contribution in the failure of buried cast iron gas pipe. Beavers and Thompson [1] stated that in natural gas transmission pipelines around 36% accidents are occurred due to external corrosion and 63% accidents are occurred due to internal corrosion while in natural gas distribution pipelines only 4% accidents are occurred due to corrosion (external corrosion). Most of the cases, failure in buried gas pipe occurs due to the formation of “Graphitisation”. When iron oxide combined with graphite in

the exterior wall of the pipe, the resulting substance is known as graphitization. This is the product developed due to corrosion and it is familiar as corrosion pit. This is the “unique” property of cast iron pipe [2]. The presence of corrosion pit appears as a normal layer on the pipe surface.

The failure of buried gas pipeline is control by number of factors such as pipe material, soil corrosion, internal and external loading, and third party etc. Among all these factors, the soil corrosion has been identified as a factor having significant contribution towards failures both small and large diameter pipes. However, a limited numbers of studies have been reported in literature to understand the effects of soil corrosion on the failure mode and mechanism of buried pipes. The soil corrosion is normally modeled analytically with time-varying parameters, which determine the rate of corrosion and corrosion pit depth at a particular time interval. Number of corrosion models is developed over the years; however, the applicability of the model predominantly depends on the type of soil and the soil moisture change over the time at the pipe depth. The remaining life of the pipe is estimated on the basis of the pipe corrosion and applied loads, which determines the stresses in the pipe segment. The failure will occur when the pipe stress exceeds the capacity, which reduces with time due to several factors such the reduction in wall thickness due corrosion, creep effect and fatigue etc. The estimation of remaining life of the pipe can show significant variability due to the selection of the corrosion model and consequently effect the pipe renewal and rehabilitation plans that finally have economic impacts. Therefore, it is important for the pipeline authorities to understand the effect of corrosion models in the remaining life calculation.

II. BACKGROUND

Different techniques were adopted by several researchers to predict the corrosion level in buried pipelines. Kumer et al. [3] developed a corrosion status index (CSI) to understand the condition of cast iron gas pipe. Dolaec et al. [4] propose a power function to correlate “pit depth” with the age of pipe. Randall-Smith et al. [5] concluded that corrosion pit grow at a constant rate and expressed a linear model to determine the remaining life of the buried pipe. To control corrosion in buried cast iron cement lined pipe, [2] proposed a “diffusion process” by dispersing ferrous ion from graphitization zone and concluded that corrosion is a function of “soil moisture content”, “soil density” and “soil water quality”, “microbiological activity” and “temperature”. For instance, case study for failure analysis of high pressure natural gas was conducted by [6] and [7] and concluded corrosion as the major

Saima Ali is with the Queensland University of Technology, Brisbane, QLD 4000, Australia. She is a PhD student in the School of Civil Engineering and Built Environment (corresponding author to provide phone: 0420553415; e-mail: shoma2011@gmail.com).

Pathamanathan Rajeev is with the Swinburne University of Technology, Melbourne, VIC 3122, Australia. He is Senior Lecturer in the Department of Civil and Construction Engineering (e-mail: prajeev@swin.edu.au).

Imteaz A. Monzur is with the Swinburne University of Technology, Melbourne, VIC 3122, Australia. He is Assistant Professor in the Department of Civil and Construction Engineering (e-mail: mimteaz@swin.edu.au).

factor to occur failure of buried gas pipe. Cooke et al. [8] conducted probability analysis in occurring failures in gas pipelines and also considered the corrosion as an important parameter. Moreover, [9] formulated “probability density function” to estimate the extent of damage in underground pipes due to corrosion and also carried out simulation to get an idea about the damage rate in a particular affected position occurred by corrosion. Besides, [10] determined failure probability in the defected locations of buried pipe on annual basis. Lee and Pyun [11] also conducted the analysis to evaluate failure probability in underground pipe considering corrosion as a significant factor.

The major common types of failures in buried cast iron pipe is blowout holes and pin holes. Blowout hole is a common type of failure in the small diameter pipe which occurs due to the combination of corrosion and the internal gas pressure through the pipe. The corrosion pit usually tends to reduce the thickness of the pipe wall. Consequently, at any particular point on the pipe wall where corrosion pit already made and so the pipe section sufficiently thinner, gas pressure blows can easily create holes resulting in such type of failure. Diameters of the holes can be varied depending on the corrosion pit as well as the gas pressure [12]. Blowout holes can be appeared near the top or bottom of the pipe. Again, pin hole in buried cast iron pipe is also occurred due to corrosion. In this type of failure, a narrow width holes and high depth pit is created on the surface of the buried cast iron pipe. Besides, circumferential failure, longitudinal cracking, and wedge splits are also accelerated because of the presence of the corrosion pit. So, considering corrosion as a crucial reason in the failure of buried cast iron pipe, analysis on some corrosion model is conducted in this study to predict the failure time of the pipes.

III. CORROSION MODEL

Rajani et al. [13] developed a corrosion model to predict the soil corrosion pit depth over exposure time period of buried cast iron pipe. The model is capable of determining the pit depth for low corrosive, medium corrosive and also high corrosive soil. The derived exponential model by Rajani et al. [13] is as follows:

$$d = a\tau + k(1 - e^{-c\tau}) \quad (1)$$

Here, a is Minimum corrosion rate (mm/ year), k and c is Corrosion parameter (mm), d is Corrosion pit depth and τ is Exposure time period for cast iron pipe. The feasible range of a , k and c is 0.0042 to 0.0336, 1.95 to 15.6 and 0.058 respectively including all types of soil of any corrosive level [13]. Again, [14] derived another corrosion model to predict the pit depth of buried cast iron pipe:

$$d = kTn \quad (2)$$

Here, d is corrosion pit depth, T is exposure time of buried cast iron pipe, k and n are constant. Figs. 1 and 2 illustrate the predicted corrosion depth following the models proposed by [13] and [14] respectively.

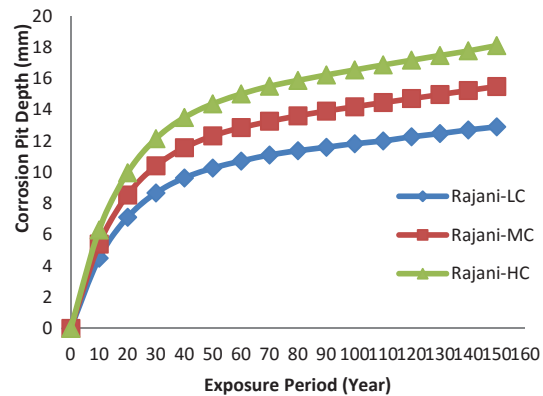

Fig. 1 Variation of Corrosion Pit Depth with Exposure Period [13]

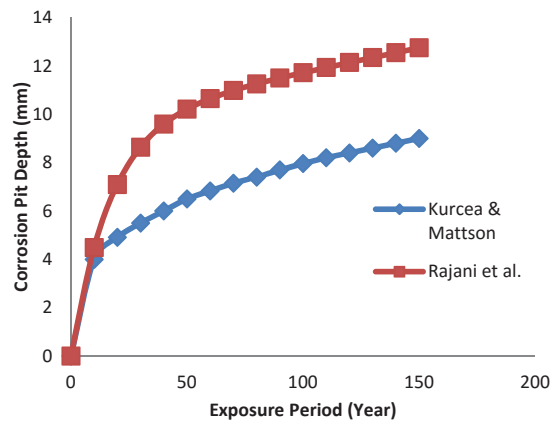

Fig. 2 Variation of Corrosion Pit Depth with Exposure Period in different models [13], [14]

IV. SENSITIVITY ANALYSIS

Sensitivity analysis is used as a helpful tool in order to identify the input constants which have more significant effects in increasing the pit depth. Sensitivity analysis is carried out for both of the corrosion models that described in the previous section. Fig. 3 illustrates the influence of the constants a and k for corrosion model of [13] over time period and Fig. 4 shows the variation of effects of k and n with exposure time of buried cast iron pipe for the model of [14].

Three different parameters are mentioned for the prediction of pit depth in buried cast iron pipe in the model of [13]. Among these, the value of one parameter is given as constant for any type of soil by [13]. So, in the sensitivity analysis, the effect of two parameters is studied. For each parameter, sensitivity analysis is conducted to the extent of 25% higher and lower amount from the median value and the summation of the values of the parameters normalized to 100%. Fig. 3 illustrates the effect of two parameters (a and k) in the variation of pit depth over a selected range of time period for the model of [13]. The figure shows that the parameter “ k ” has much significant influence (about 95%) to accelerate the pit depth in compared to parameter “ a ” and the effect is more significant at the initial stage of pipe life. However, the effect

of parameter “k” reduces gradually with the period of time. On the other hand, the effect of parameter “a” increases slightly over the time period. The combined effect of the parameters “a” and “k” are expected to be highest in developing pit depth at 50 years to 60 years of the service life of buried cast iron pipe.

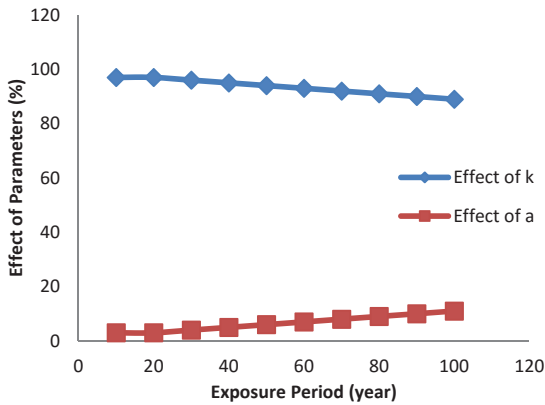

Fig. 3 Effect of a and k over time period

In the model of [14], two parameters are introduced to determine the pit depth at various time period of buried cast iron pipe. In this case, the sensitivity analysis is also carried out in the similar way as conducted for [12]. Fig. 4 demonstrates the effect of the two parameters (n and k) on the predicted pit depth throughout the service life of the buried cast iron pipe. At the initial stage of the service life of the buried pipe, the parameter “k” has a higher (about 20%) effect than the parameter “n”. However, immediately after the initial period, the effect of “n” tends to increase gradually and the effect of “k” tends to decrease slightly. At about 30 year life of the buried pipe, both the parameters contribute equally. As the pipe age increases to terminal value of the selected range, the effects of the parameters become nearly constant and the effect of “n” becomes more significant compared to that for the parameter “k”.

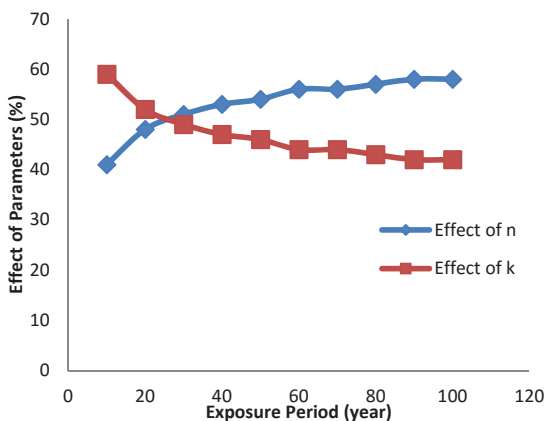

Fig. 4 Effect of n and k over time period

V.DETERMINATION OF SERVICE LIFE OF BURIED PIPE

The service life of buried cast iron pipe is determined by using both of the models proposed by [13] and [14]. To conduct this, a small diameter buried cast iron gas pipe with 300 mm diameter and 15 mm thickness is selected. The pipe is assumed to be buried at 800 mm below the ground level and surrounded by soil density of 20 KN/m³. The buried pipe experiences gas pressure of 70 kpa and ultimate strength of the pipe section is 100 MPa. In the analysis, lateral earth pressure on the pipe section is not considered and only cross-section of the pipe is considered for stress calculation instead of 3D model. The details are illustrated in Fig. 5.

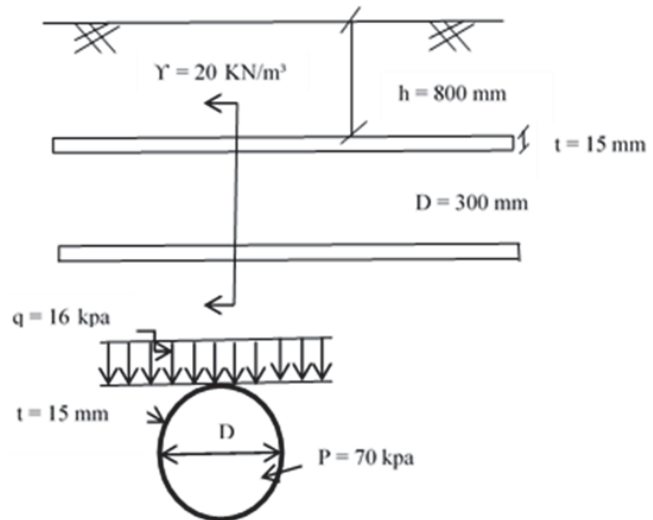

Fig. 5 Details of buried cast iron pipe

A number of combinations are formed by using the variables demonstrated by [13] and [14]. These combinations are utilized to predict the pit depth in buried cast iron pipe in several years with the models proposed by [13] and [14]. Consequently, the remaining thickness of the pipe is determined for each combination and the corresponding maximum stress and factor of safety is calculated as:

$$\sigma_{max} = pr/t + qr^2/2t \tag{3}$$

$$FS = \sigma_{ult} / \sigma_{max} \tag{4}$$

Figs. 6 and 7 show the variation of factor of safety with time period for the selected buried cast iron pipe. Figs. 6 and 7 show that for any combination, the factor of safety decreases with the increase of the exposure period of buried cast iron pipe. The life time of buried cast iron gas pipe is determined as the exposure period at which the factor of safety becomes one. With the selected combinations, in model of [13], the pipe is predicted to be break down at 80 years of service life. In the model of [14], the predicted failure time for the pipe is 90 years.

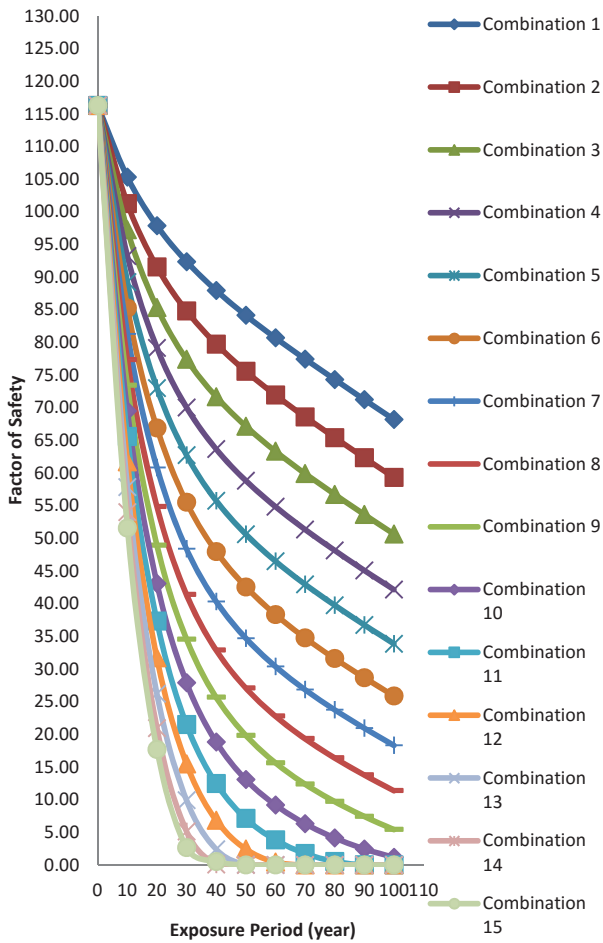

Fig. 6 Determination of service life of buried cast iron pipe (using model of [13])

VI. CONCLUSIONS

Soil corrosion has significant adverse effect in the degradation of the surface of the buried cast iron pipe and consequently developing pit. The prediction of corrosion pit depth is crucial to determine the remaining life of the cast iron pipe. In this study, a brief review is presented regarding the prediction of corrosion pit model by several researchers. Among these, the models proposed by [13] and [14] are used to conduct the sensitivity analysis for buried cast iron gas pipe. In the model developed by [14], the parameter “k” has more significant influence on producing pit depth compared to the parameter “a”. However, with the increase of exposure time, the effect of parameter “k” is decreases and the effect of parameter “a” is increases although the variation is very small. In the model of [13], the contribution of parameter “k” in developing pit depth continues to decrease and the effect of parameter “a” continues to increase moderately with time. However, at about 30 years of service life of the buried cast iron pipe, equal effect is observed from these two parameters. Moreover, using these two models, different combinations are formed to observe the variation of factor of safety with time. The remaining life of the pipe is also estimated from these

variations for models of both [13] and [14].

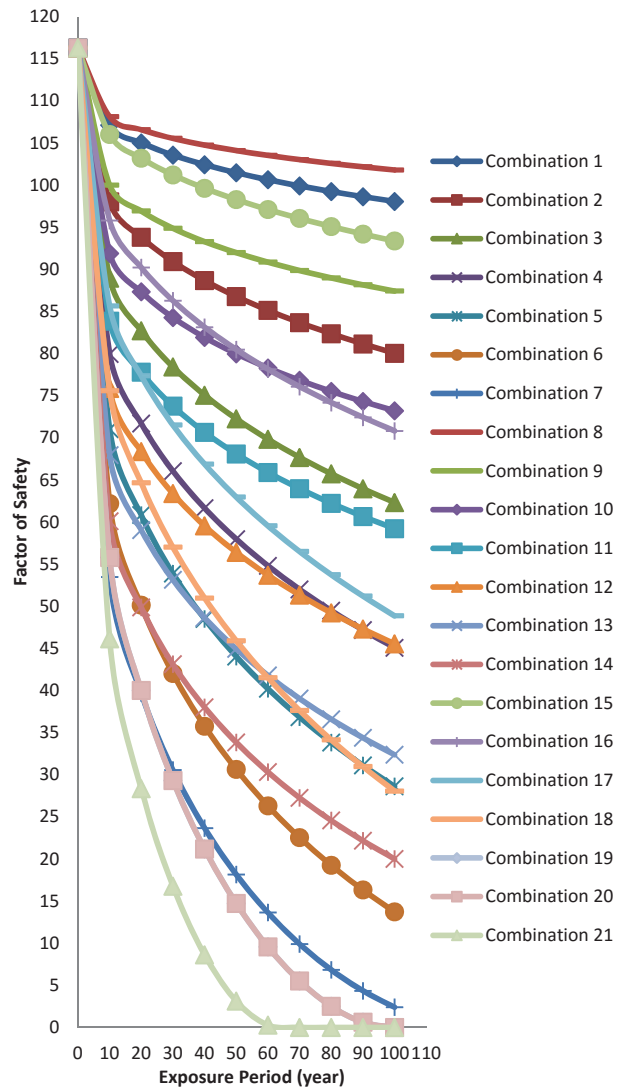

Fig. 7 Determination of service life of buried cast iron pipe (using model of [14])

REFERENCES

- [1] J.A. Beavers, and N.G. Thompson, (2006). “External Corrosion of Oil and Natural Gas Pipelines.” ASM Handbook, vol. 13C, Corrosion: Environment and Industries.
- [2] R.B. Petersen, and R.E. Melchers (2012). “Long-Term Corrosion of Cast Iron Cement Lined Pipes.” Corrosion and Prevention 2012, Paper 23.
- [3] A. Kumar, E. Meronyk, and E. Segan (1984). “Development of Concepts for Corrosion Assessment and Evaluation of Underground Pipelines.” US Army Corps of Engineers, Construction Engineering Research Laboratory, Technical Report CERL-TR-M-337, II.
- [4] M.L. Dolac, (1979). “Time-to-Failure Analysis of Cast Iron Water Mains.” Report Submitted to the City of Vancouver by CH2M HILL, BC, Canada.
- [5] M. Randall-Smith, A. Russel, and R. Oliphant (1992). “Guidance Manual for the Structural Condition Assessment of the Trunk Mains.” Water Research Centre, Swindon, UK.
- [6] F. Hassan, J. Iqbal, and F. Ahmed (2007). “Stress Corrosion Failure of High Pressure Gas Pipeline.” Engineering Failure Analysis, vol. 14, pp. 801-809.

- [7] R.M. Hemandaz, D.D. Martinez, R. Gonzalez, E.A. Perez, S.R. Mercado, and J. Rodriguez (2007). "Corrosive Wear Failure Analysis in a Natural Gas Pipeline." *Wear*, vol. 263, pp. 567-571.
- [8] R.M. Cooke, E. Jager, D. Lewandowski (2002). "Reliability model for underground gas pipelines." *Probabilistic safety assessment and management*, Elsevier, pp. 1045-1050.
- [9] J.L. Alamilla., and E. Sosa, (2008). "Stochastic modeling of corrosion damage propagation in active sites from field inspection data." *Elsevier Journal of Corrosion Science*, vol. 50, pp. 1811-1819.
- [10] M. Lechi (2011). "Evaluation of predictive assessment reliability on corroded transmission pipelines." *Elsevier Journal of Natural Gas Science and Engineering*, vol. 3, pp. 633-641.
- [11] O.S. Lee, and J.S. Pyun, (2002). "Failure probability of corrosion pipeline with varying boundary condition." *KSME International Journal*, vol. 16(7), pp. 889-895.
- [12] J.M. Marker, R. Desnoyers, and S.E. McDonald (2001). "Failure Modes and Mechanism in Gray Cast Iron Pipe." *Underground Infrastructure Research: Municipal, Industrial and Environmental Applications*, Proceedings, Kitchener, Ontario, June 10-13, 2001, pp. 1-10.
- [13] B. Rajani and S. Tesfamariam (2007). "Estimating Time to Failures of Cast Iron Water Mains". *Proceedings of the Institution of Civil Engineers, Water Management* 160, pp. 83-88.
- [14] V. Kurcea, E. Mattson (1987). "Atmospheric Corrosion". In: Mansfield F, editor. *Corrosion mechanics*. New York, NY: Merceel Dekker.