

Combined Fuzzy and Predictive Controller for Unity Power Factor Converter

Abdelhalim Kessal

Abstract—This paper treats a design of combined control of a single phase power factor correction (PFC). The strategy of the proposed control is based on two parts, the first, for the outer loop (DC output regulated voltage), and the second govern the input current of the converter in order to achieve a sinusoidal form in phase with the grid voltage. Two kinds of regulators are used, Fuzzy controller for the outer loop and predictive controller for the inner loop. The controllers are verified and discussed through simulation under MATLAB/Simulink platform. Also an experimental confirmation is applied. Results present a high dynamic performance under various parameters changes.

Keywords—Boost converter, harmonic distortion, Fuzzy, prediction, unity power factor.

I. INTRODUCTION

RECENTLY, the power converters have been employed in a wide range of industrial sectors and energy conversion. Due to increase energy demands and appear renewable energy (photovoltaic and wind), researches in power converters have become an interest topic today. Moreover, more than 60% of the utility power dissipated before it is finally consumed due to: network pollution, harmonics distortion and insufficiency of power supplies; for these reasons, many countries in the world created legalism to limit energy dissipation. One of these laws is producing an electronics appliances have a high-performance with low harmonic distortion. To fulfill these goals, power factor corrector (PFC) appears such as an enabling technology for improvement of power supplies. The main feature of latest power converters that improved the requirement of efficiency, fast operation and sophistication in performance, have achieved by a switching mode operation. This later includes two states (ON/OFF) fashion and has been developed due to new invention in semiconductor technologies [1].

In literature, there are many kinds of power converters. Among these converters, the boost converter is currently the most popular, which is used in a wide range of electronic appliances.

To ensure the converted AC/DC, usually a bridge of diodes is used, this later tends to have a non-sinusoidal current and a low power factor nearly to 0.6 due to nonlinear behavior of circuit. To solve this problem one mean possible: add PFC circuit. Moreover, the cost global of devices will be increased with 10 to 25%; on the other hand, the cost of saved energy will cover the cost of PFC.

Abdelhalim Kessal is with the Bordj Bou Arréridj University, Faculty of Sciences & Technology, Algeria (e-mail: (Abdelhalim.kessal@yahoo.fr).

Active PFC increases in recent few years in wide range of industrial power supplies. This later involves a pre-regulator between the rectifier and the load (Fig. 1) [2]. By controlling of applied switching, the current will be taken its sinusoidal drawn like source voltage, also the total harmonic distortion (THD) will be decreased. Several control strategies have been proposed for the control of boost converters, such as PI control [3], neural networks [4], predictive control [5]-[8], fuzzy logic control [9] sliding mode control [2], and other [10], [11]. Taking into account the efficiency of devices, ensuring conversion with less weight and cost. The fuzzy logic with predictive method can be a suitable solution.

Fuzzy logic is considered as solution when a high nonlinearity and ambiguity of the system have been considered. It is used in many areas such as: identification, control and diagnostic of a complex system [12]. The fuzzy logic is founded by Zadeh in 1963 [13]. Construction and understand are very easy because the controller does not need mathematical modeling; According to Zadeh concept, the system behavior is converted to linguist rules, this later is used to develop a control strategy [14]. The application of fuzzy logic for power factor corrector can give improvements [9], because it can enhance the performance of the system and offers good responses during the variation of load values or output voltage reference value. There is several works which use fuzzy logic for APFC, but these works apply high number of rules, which will exhibit an additional cost and decrease the rapidity of devices. So, in this work we try using FLC with a few rules number compared to previous works. Meanwhile, the predictive control has been introduced to current control, this later has been extended for a wide range of power converter and electric derives. This kind of control allows the system to present good robustness.

The primary task of this work is to develop a new method based on predictive control and Takagi Sugeno Fuzzy logic for single phase active power factor correction in order to supply by sinusoidal current in phase with grid voltage. The simulation under Matlab/Simulink and its implementation on real time by using dSPACE1104 are carried out for improve the efficiency and possibility of commercialization this technique in future. Also, several robustness tests have been done, by the changing load values and output voltage reference.

II. MATHEMATICAL MODELING

The basic conception of the boost converter is illustrated in Fig. 1. According to state of the switch, two function modes are founded. The first mode operation Fig. 1 (b), in this case

the switch S is turned on ($S= 1$), the current will be accumulates. Also, the energy has been saved in the inductor and the capacitor supplies the load. The second mode operation Fig. 1 (c), the switch S is turned off ($S= 0$). The

quantity of stored energy in the inductor and the source energy both will be transferred to the output (capacitor–load). Moreover, the power circuit has been changed his mode. The model of boost PFC can be represented as (1) [2], [3], [9].

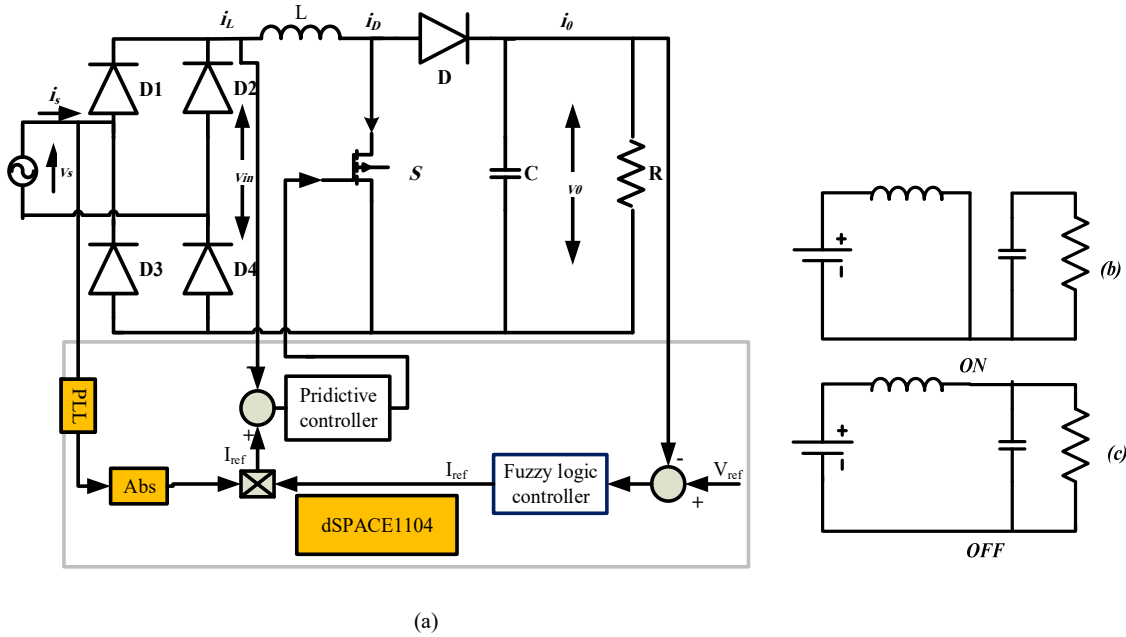

Fig. 1 PFC pre-regulator

$$\begin{cases} C \frac{dv_o}{dt} = (1 - S)i_L - i_o \\ L \frac{di_L}{dt} = v_{in} - (1 - S)v_o \end{cases} \quad (1)$$

To get a sinusoidal current in phase with the source voltage, a control law has introduced, to achieve a way that the resistive load equal to the ratio of v_{in} and i_L .

III. PREDICTIVE CURRENT CONTROL

Predictive control become increasingly popular over some decades, its application for power electronics is rather new. Due to its attractive characteristics, the predictive control changes the concept of classical controller, which unable or less its performance if it's integrated with the new power converters that use a switching mode operation. In this work predictive control has been used for control of the converter switch. Taking into account the state of the switch from the circuit shown in Fig. 1, the equations of the current of inductor $i_L(t)$ for each state can be expressed as [8]:

For switch S is turned on:

$$L \frac{di_L}{dt} = v_{in}(t) \text{ for } t(k) \leq t < t(k) + d(k).T_s \quad (2)$$

For switch S is turned off:

$$L \frac{di_L}{dt} = v_{in}(t) - v_o(t) \text{ for } t(k) + d(k).T_s \leq t < t(k+1) \quad (3)$$

where $t(k)$ and $t(k+1)$ are the started time of the k^{th} and $(k+1)^{th}$ switching cycle respectively, $d(k)$ and T_s are the duty cycle and switching period respectively.

Since the switching period is more than the input voltage frequency, (3) and (4) can be rewritten as:

$$L \frac{i_L(t(k)+d(k).T_s) - i_L(t(k))}{d(k).T_s} = v_{in}(t(k)) \quad (4)$$

$$L \frac{i_L(t(k+1)) - i_L(t(k)+d(k).T_s)}{(1-d(k)).T_s} = v_{in}(t(k)) - v_o(t(k)) \quad (5)$$

The diagram shown in Fig. 2 presents the inductor current during one switching cycle [8].

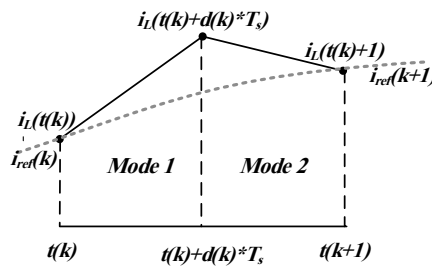

Fig. 2 Inductor current during one switching cycle

At instant $t(k)+d(k).T_s$, the inductor current can be derived as (6):

$$i_L(t(k) + d(k).T_s) = i_L(t(k)) + \frac{1}{L} v_{in}(t(k)).d(k).T_s \quad (6)$$

At the start time of switching cycle $(k+1)^{th}$, the inductor current can be derived as follow:

$$i_L(t(k+1)) = i_L(t(k) + d(k).T_s) + \frac{1}{L}(v_{in}(t(k)) - v_o(t(k)).(1 - d(k)).T_s \quad (7)$$

Substituting (6) and (7), the inductor current can be derived as:

$$i_L(t(k+1)) = i_L(t(k)) + \frac{1}{L}v_{in}(t(k)).T_s - \frac{1}{L}v_o(t(k)).(1 - d(k)).T_s \quad (8)$$

The discrete form of (8) can be expressed as:

$$i_L(k+1) = i_L(k) + \frac{v_{in}(k).T_s}{L} - \frac{v_o(k).(1-d(k)).T_s}{L} \quad (9)$$

According to (9), the inductor current at the next switching cycle is calculated by the inductor current at the present switching cycle.

To calculate the duty cycle $d(k)$, (8) can be rewritten as:

$$d(k) = \frac{L}{T_s} \cdot \frac{i_L(k+1) - i_L(k)}{v_o(k)} + \frac{v_o(k) - v_{in}(k)}{v_o(k)} \quad (10)$$

Through the boost circuits parameters such as input voltage, output voltage and inductor current, the duty cycle $d(k)$ for the actual switching cycle has been calculated.

For designed the boost converter with APFC, the inductor current $i_L(k+1)$ has been forced to follows his reference $i_{ref}(k+1)$, which have a sinusoidal form.

Substituting V_0 , $i_L(k+1)$ in (10) by his references, the duty cycle can be expressed as:

$$d(k) = \frac{L}{T_s} \cdot \frac{i_{ref}(k+1) - i_L(k)}{V_{ref}(k)} + \frac{V_{ref}(k) - v_{in}(k)}{V_{ref}(k)} \quad (11)$$

The reference current i_{ref} in (11) has been calculated as (12):

$$I_{ref}(k+1) = K_{fuzzy} \cdot |\sin(\omega_{line} \cdot t(k+1))| \quad (12)$$

K_{fuzzy} is the peak value of the reference current, that given by the output of the voltage loop controller, which detailed in the following section.

IV.FUZZY LOGIC BASED DC BUS VOLTAGE CONTROLLER

Due to its simple structure and robustness, FLC became vital in very important researchers in many fields of electrical engineering. The research for enhancing the characteristics of FLC does not abrupt since 1973. In this work, the FLC has been used in order to regulate and maintain dc-link voltage of the boost converter that depicted in Fig. 1 in desired value. The FLC contains two inputs variables Fig. 3, the first is error $e(k)$, which calculated such as deference between measured dc-link voltage and desired reference voltage, the second input consists of the change in voltage error $\Delta e(k)$, this later helps the controller to be fast and efficient. As output, the reference current i_{ref} is produced.

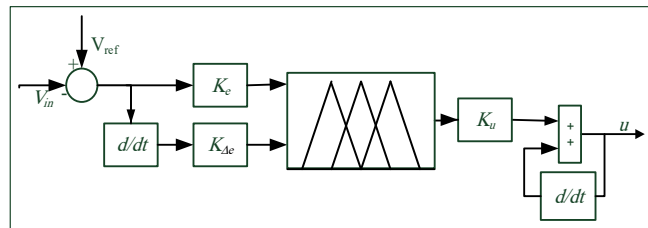

Fig. 3 Fuzzy logic controller

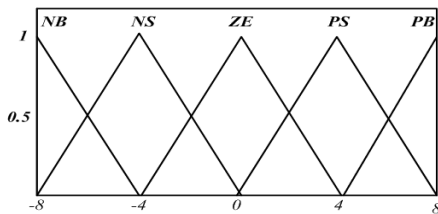

Fig. 4 Membership functions for inputs variable

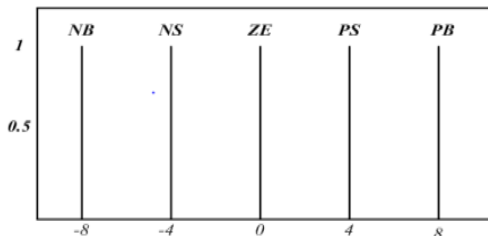

Fig. 5 Membership functions for output variable

According to Fig. 3, the controller is normalized by using scaling factors to get an optimal performance as follow:

$$\begin{cases} u_k = u_{k-1} + K_u \cdot u_k \\ e = K_e \cdot e \\ \Delta e = K_{\Delta e} \cdot \Delta e \end{cases} \quad (13)$$

A total of 25 rules are designed to get the best performance of the controller as illustrated in Table I.

| Error e(k) | Change in Error Δe(k) | | | | |
|------------|-----------------------|----|----|----|----|
| | NB | NS | ZE | PS | PB |
| NB | NB | NB | NS | NS | ZE |
| NS | NB | NB | NS | ZE | PS |
| ZE | NB | NS | ZE | PS | PB |
| PS | NS | ZE | PS | PS | PB |
| PB | ZE | PS | PS | PB | PB |

All steps of the proposed method are as Fig. 6.

- Step 1. Identification of the parameters.
- Step 2. Determinate of suitable voltage and introduce the FLC for regulation.
- Step 3. Determinate I_{ref} through FLC for efficient of the suitable mode and introduce predictive control.
- Step 4. Verified that of all duty cycles are calculated by predictive control.
- Step 5. Exploitation of the converter.

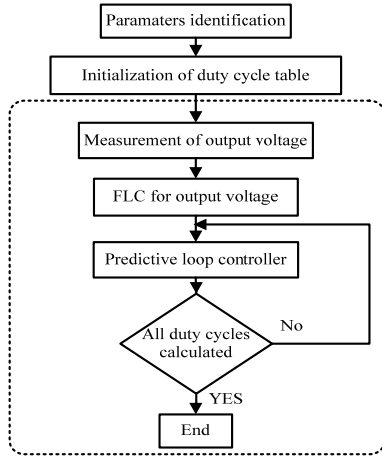

Fig. 6 Flowchart of applied method

V. SIMULATION RESULTS

The simulation of the model was carried out through the MATLAB/Simulink environment with a fixed-step size of $40e-6$ s; the main parameters of the model are given in Table II. Simulation results of the system with constant load (200 Ω) and constant DC link voltage (110V) are shown in Fig. 7. Moreover, various simulation tests have been done to evaluate the dynamic performance of the controller during the variation of DC link voltage reference as given in Fig. 8 and steps of load as shown in Fig. 9.

According to Figs. 1-9, it can be observed that the proposed control strategy is robust and did not influenced during the changes in parameters (load, output voltage reference), the current take a sinusoidal form and in phase with the grid voltage, steady state error and settling time are enhanced and the output voltage follows the reference value perfectly.

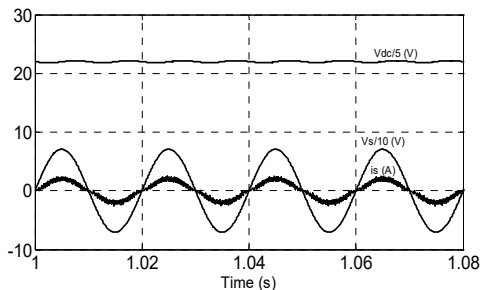

Fig. 7 Simulation results, input and output voltage, input current

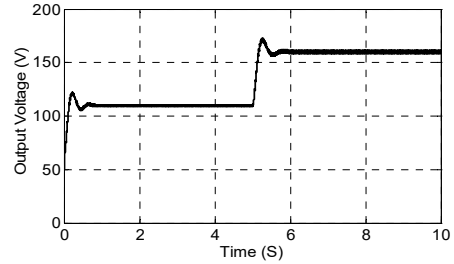

Fig. 8 Variation of output voltage from 110V to 160V

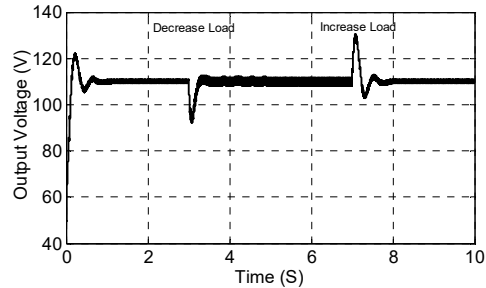

Fig. 9 Variation of load from 200Ω to 100Ω and from 100Ω to 200Ω

| TABLE II CIRCUIT PARAMETERS | |
|--------------------------------|--------|
| Switching frequency | 20KHz |
| Resistance load | 200Ω |
| Output capacity | 1100μF |
| Input inductance | 20mH |
| DC-link voltage reference | 110 V |
| Source voltage frequency | 50Hz |
| Supply voltage (RMS) | 50V |

VI. EXPERIMENTAL RESULTS AND DISCUSSION

To validate of the proposed method, an experimental test bench has been developed as shown in Fig. 10 in LAS laboratory, Setif 1 University, Algeria. The prototype contains: Inverter (SEMIKRON, 20KVA, 1200V, 50A) used such as rectifier, transformer (12KVA, 380/220 V), current sensors, voltage sensors. The control program has been simulated in MATLAB/Simulink environment and implanted on real time through the dSPACE RTI1104.

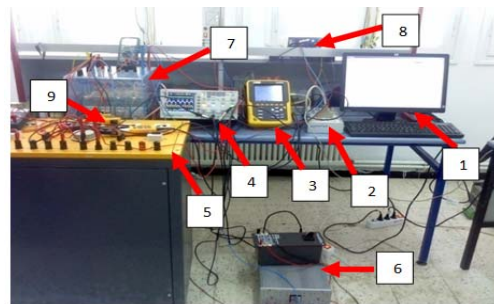

Fig. 10 Experimental test bench components: (1: PC, 2: dSPACE I/O connectors, 3: Power Analyzer, 4: Scope, 5: transformer, 6: resistive load, 7: Inverter, 8: voltage sensor, 9: current sensor

Test 1: The first test has been done without APFC controller, the experimental results in Fig. 11; presents a poor performance; induce a high THD around 52.8% with a lower PF around 0.78. Also, the current take a bad waveform due to load influence. These results affirm the importance of APFC.

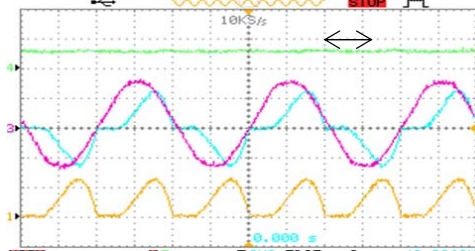

Fig. 11 Experimental results without APFC: Source voltage (50V/div), input and inductor current (1A/div) and DC voltage (100V/div)

Test 2: In this test, the model is tested with APFC, results are presented in Figs. 12 and 13, which highlight the effect of APFC with fixed load (200 Ω) and output voltage (110 V), it's observed that the output voltage follows the desired reference, the source current is in phase with the input voltage. Hence, the THD is around 5% and PF is nearly 0.992, have been improved compared to the previous tests.

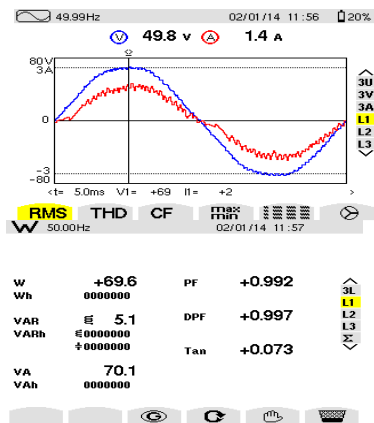

Fig. 12 Experimental measurement: PF, voltage and current of source

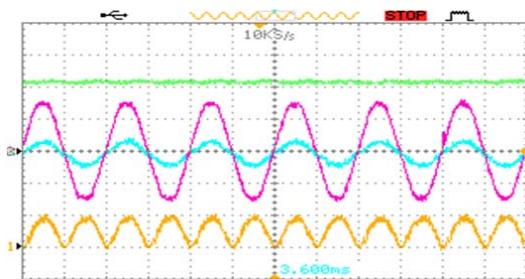

Fig. 13 Experimental results: Source voltage (50V/div), source current (5A/div) inductor current (2A/div) input voltage and output DC voltage (50V/div)

Test under load changes: in this test a load variation was applied, in order to test the influence of the load perturbation. Fig. 14 shows a slight remoteness of the output voltage due to sudden load changes, but did not decrease the system performance.

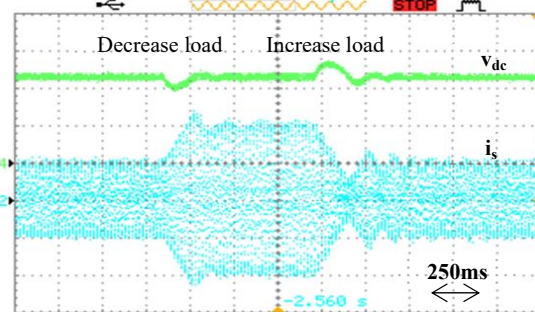

Fig. 14 Experimental results for load variation, output DC voltage (50V/div) and input current (2A/div)

Test under voltage reference changes: the value of output voltage reference has risen around (160v), the results as shown in Fig.15, and these later shows that the output voltage follows the reference with a lower settling time.

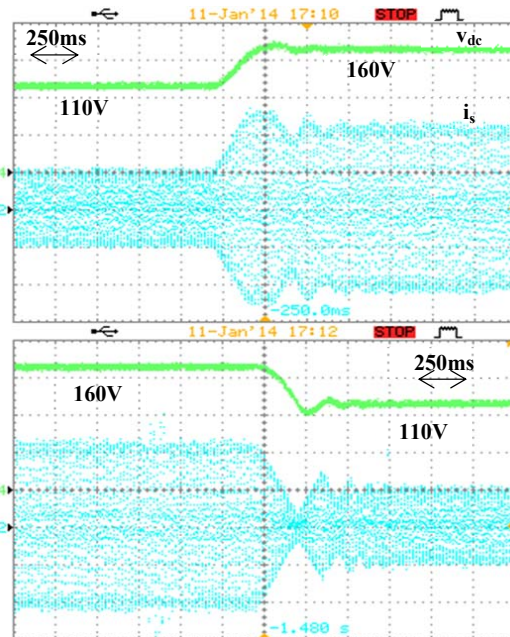

Fig. 15 Experimental results for voltage variation, increasing from 110 V to 160 V, decreasing from 160 V to 110 V

VII.CONCLUSION

In this work, the control of single phase power factor correction has been studied, which consists of a two intelligent controllers, fuzzy logic and predictive technique, which is simple and yet efficient. The proposed techniques have successfully simulated and implanted on real time through dSPACE 1104. The simulation results have been presented

and confirmed by experimental tests, in both, a high efficiency is obtained, which resides in, unity power factor, reduced harmonic distortion, robustness during parameters variations (time response). As a future perspective, an artificial neural network will be introduced to optimize the scaling factor of fuzzy logic in case where they are an ambiguity in measurement.

REFERENCES

- [1] Rodriguez J, Cortes P. Predictive control of power converters and electrical drives. John Wiley 2012.
- [2] Kessal A, Rahmani L. Analysis and design of sliding mode controller gains for boost power factor corrector. ISA Transactions 2013; 52: 638–643.
- [3] Kessal A, Rahmani L, Gaubert J, Mostefai M. Analysis and design of an isolated single-phase power factor corrector with a fast regulation. Electric Power Systems Research 2011; 8:1825–1831.
- [4] Sagioglu S, Colak I, Bayindir R. Power factor correction technique based on artificial neural networks. Energy Conversion and Management 2006; 47:3204–3215.
- [5] Perez M, Rodriguez J, Coccia A. Predictive current control in a single phase PFC boost rectifier. IEEE international conference on industrial technology ICIT 2009:1-6
- [6] Rao VM, Jain AK, Reddy KK, Behal A. Experimental comparison of digital implementations of single-Phase PFC controllers. IEEE Transactions on industrial electronics 2008; 55(1):67-78.
- [7] Chen J, Prodić A, Erickson RW, Maksimović D. Predictive Digital Current Programmed Control. IEEE Transactions on power electronics 2003; 18 (1):411-419.
- [8] Bibian S, Jin H. Digital control with improved performance for boost power factor correction circuits. Sixteenth annual IEEE Conference Applied Power Electronics conference and Exposition APEC 2001; 1: 137–143.
- [9] Kessal A, Rahmani L, Mostefai M, Gaubert J. Power factor correction based on fuzzy logic controller with fixed switching frequency. Electronics and electrical engineering 2012; 180 (2): 67-72.
- [10] Chen T.C, Ren T.J, Ou J.C. Fixed switching frequency applied in single-phase boost AC to DC converter. Energy Conversion and Management 2009; 50: 2659–2664.
- [11] Genç N, Iskender I. An improved soft switched PWM interleaved boost AC–DC converter. Energy Conversion and Management 2011; 52: 403–413.
- [12] Kovačić Z, Bogdan S. Fuzzy Controller Design: Theory and Applications. Taylor & Francis. 2006.
- [13] Zadeh L.A. Fuzzy sets. Information and Control 1965; 8: 338–353.
- [14] Zadeh L.A. Is there a need for fuzzy logic? Information Sciences 2008; 178: 2751–2779.

Abdelhalim KESSAL was born in Algeria in 1975. He received the Engineering degree in electrical engineering from the University of Setif, Setif, Algeria, in 1997, the Master's and Ph. D degrees in electrical engineering from the University of Setif, Setif, Algeria, in 2002 and 2012.. He is currently an Assistant Professor and the Head of Electrical Engineering Department at University of Bordj Bou Arréridj. His main research interests are modeling and control of power converters, fuzzy logic control, nonlinear control and predictive control applied to power electronics systems such as power factor corrector.