

Numerical Simulation of Heating Characteristics in a Microwave T-Prong Antenna for Cancer Therapy

M. Chaichanyut, S. Tungjitkusolmun

Abstract—This research is presented with microwave (MW) ablation by using the T-Prong monopole antennas. In the study, three-dimensional (3D) finite-element methods (FEM) were utilized to analyse: the tissue heat flux, temperature distributions (heating pattern) and volume destruction during MW ablation in liver cancer tissue. The configurations of T-Prong monopole antennas were considered: Three T-prong antenna, Expand T-Prong antenna and Arrow T-Prong antenna. The 3D FEMs solutions were based on Maxwell and bio-heat equations. The microwave power deliveries were 10 W; the duration of ablation in all cases was 300s. Our numerical result, heat flux and the hotspot occurred at the tip of the T-prong antenna for all cases. The temperature distribution pattern of all antennas was teardrop. The Arrow T-Prong antenna can induce the highest temperature within cancer tissue. The microwave ablation was successful when the region where the temperatures exceed 50°C (i.e. complete destruction). The Expand T-Prong antenna could complete destruction the liver cancer tissue was maximized (6.05 cm³). The ablation pattern or axial ratio (Widest/length) of Expand T-Prong antenna and Arrow T-Prong antenna was 1, but the axial ratio of Three T-prong antenna of about 1.15.

Keywords—Liver cancer, T-Prong antenna, Finite element, Microwave ablation.

I. INTRODUCTION

THE standard in the treatment of cancerous tumors is to remove all of the cancer together with a sufficient margin of healthy tissue, to prevent local recurrence. Recent investigations present techniques, minimally or totally noninvasive: heating using microwaves [1], radio frequency [2], interstitial laser photocoagulation [3], focused ultrasound [4], and cryotherapy [5].

Microwave ablation therapies use the electromagnetic field radiated by a microwave antenna as the energy source to increase the temperature into the target tissue. The antenna is inserted into the human body following natural orifices and veins (intracavitary antennas), or percutaneously (interstitial antennas). Other types of energy sources can be used as a laser, radio frequency currents, and ultrasounds. Comparisons among the different energy sources have shown that microwaves are good candidates for ablating larger regions within the tissues.

This work is supported by King Mongkut's Institute of Technology Ladkrabang (KMITL) (KMITL Research Fund to S. Tungjitkusolmun).

M. Chaichanyut is with the Faculty of Engineering, Department of Electronic Engineering, King Mongkut's Institute of Technology Ladkrabang, Bangkok 10520, Thailand (e-mail: kcmontre@kmitl.ac.th).

S. Tungjitkusolmun is with the Faculty of Engineering, Department of Electronic Engineering, King Mongkut's Institute of Technology Ladkrabang, Bangkok 10520, Thailand (Corresponding author; e-mail: ktsupan@kmitl.ac.th).

The examples of the MW antennas for ablation on previous research were: the monopoles antenna [6], dipole or floating sleeve dipole antenna [7], choke or cap-choke antenna [8], triaxial antenna [9], metal tip monopole antenna [10], open tip monopole antenna [10] and an open slot and multi-slot antennas [11].

It is important to determine the expected size and shape of a single-session ablative zone and its relationship to the microwave antenna used to achieve complete tumor ablation in fewer treatment sessions. Thus, this paper describes the design and development of a T-Prong monopole antenna. The configuration of T-prong monopole antennas was shown in Fig. 1. They are: (a). Three T-prong Monopole (3TP), (b). Expand T-Prong antenna (ETP) and (c). Arrow T-Prong antenna (ATP).

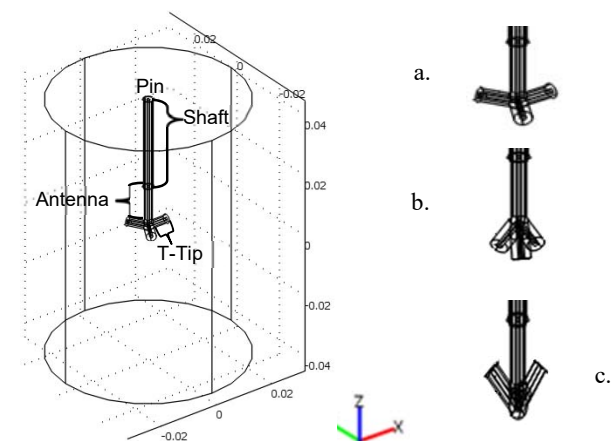

Fig. 1 The configurations of the geometry model of the T-Prong monopole antennas: (a) Three T-prong Monopole (3TP), (b) Expand T-Prong antenna (ETP) and (c) Arrow T-Prong antenna (ATP)

The antenna structure supports the propagation of microwave energy at 2.45 GHz. In this work, a numerical study is presented to simulate heat flux, ablation zone or lesion pattern and volume destruction by different antennas. Then, the temperature increase is calculated by the bio-heat equation in biology.

II. MATERIALS AND METHODS

This section shows the application of computer software to aid in the simulation. A new simulated interstitial applicator for microwave ablation referred as T-Prong monopole antenna has been proposed. We adopt the commercial software COMSOL as a numerical model. We first solve the Maxwell

equations and compute the electromagnetic specific absorption rate. The results are then used to solve the bio-heat equation to obtain the lesion pattern in the cancerous tissues.

A. Antenna Design

The T-Prong monopole antennas were adapted from monopole antenna. These antennas are easily fed through an open-ended coaxial transmission line. The T-Prong monopole antenna has the ability to propagate in a single mode where the magnetic and electric fields are both perpendicular to the propagation direction (TEM). The Multiflex_141 coaxial cable has been selected to design the T-Prong monopole antenna, a coaxial cable consists of inner and outer conductors along the same cylindrical axis separated by a low-loss dielectric. For T-Prong monopole antenna, the end of the inner conductor may remain open or coated with dielectric or metal [7] and connect to T-tip (see in Fig. 1).

B. Governing Equations

The microwave power is propagated into the domain of our system. The current density and the electric field intensity were evaluated using Laplace's equation.

$$J = \sigma E + j\omega \varepsilon E \quad (1)$$

where J is the current density (A/mm), E is the electric field intensity (V/mm), ω is the angular frequency (rad) and ε is the electric permittivity (F/m). The temperature distribution in the tissue was obtained by solving Pennes bio-heat equation [12].

$$\rho c \frac{\partial T}{\partial t} = \nabla \cdot k \nabla T + J \cdot E - h_{bl}(T - T_{bl}) + Q_m \quad (2)$$

$$h_{bl} = \rho_{bl} c_{bl} \omega_{bl}$$

where ρ is the Density (kg/m^3); c is the Specific heat ($\text{J/kg}\cdot\text{K}$); k is the Thermal conductivity ($\text{W/m}\cdot\text{K}$); T_{bl} is the temperature of the blood; ρ_{bl} is the blood density (kg/m^3); c_{bl} is the Specific heat of the blood ($\text{J/kg}\cdot\text{K}$); ω_{bl} is blood perfusion (1/s) and the h_{bl} is the convective heat transfer coefficient accounting for blood perfusion in the model. The metabolic heat generation rate of $33\ 800\ \text{W/m}^3$ is used (Q_m) (W/m^3). [12].

C. Geometries Model

We utilized the numerical modeling to solve 3D FE analyses in order to obtain temperature distributions during MW ablation. We solved our FE models using COMSOL Multiphysics 3.5a (COMSOL, Inc., Burlington, MA). The software allows specifying the geometry of antenna design; the geometric model is sketched in Fig 1. We design the dimensions of the geometric model for analyses were: the liver cancer was cylindrical shape (diameter= 60 mm and length = 60 mm). The dimensions of the T-Prong monopole antennas are listed in Table I, while its material properties are shown in Tables II and III respectively [13], [14].

TABLE I
THE SPECIFICATIONS OF GEOMETRIC MODELS

Type	Shaft (mm)	Antenna (mm)	T- tip (mm)	Cancer (mm)	Angle θ	Angle ρ
3TP	29	13	6.5	30	90	120
ETP	29	13	6.5	30	150	120
ATP	29	13	6.5	30	45	90

TABLE II
MATERIAL PROPERTIES FOR ELECTROMAGNETIC ANALYSIS AT 2.45GHZ

Properties	Liver cancer	Dielectric	Conductor
Relative permittivity (ε_r)	43.03	2.03	
Relative permeability (μ_r)	1	1	PEC*
Conductivity (σ) [s/m]	1.79	10^{-5}	

* PEC (Perfect electric conductor)

TABLE III
MATERIAL PROPERTIES FOR THERMAL ANALYSIS

Material	ρ [kg/m^3]	c [$\text{J/kg}\cdot\text{K}$]	k [$\text{W/m}\cdot\text{K}$]	σ [S/m]
Conductor	6450	840	18	10^8
Liver cancer	1060	3600	0.512	1.79
Dielectric	70	1045	0.026	10^{-5}
Shaft	70	1045	0.026	10^{-5}

TABLE IV
THE NUMBERS OF ELEMENT AND NODE OF EACH ANTENNA

Antenna Type	Nodes	Elements
3TP	352885	314687
ETP	351486	313705
ATP	351145	312814

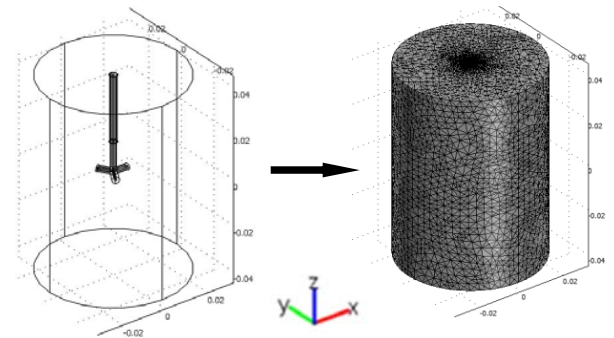

Fig. 2 The cross-section of the meshed model

The boundary conditions assigned to FEMs in this study complied with the following [15]:

- The propagation mode for the microwave was assumed to be TEM, where the feeding source was launched inside the cable. The total field was computed by the technique of the scattering problem
- The tangential electric field is zero by defining all perfect conducting boundaries, such as the conductors in the coaxial cable.
- The boundary of the coaxial input port is a hard feeding source aperture. For this type of source aperture, the port is treated as a hard source, launching an incident wave, but not allowing any reflected wave to be absorbed.

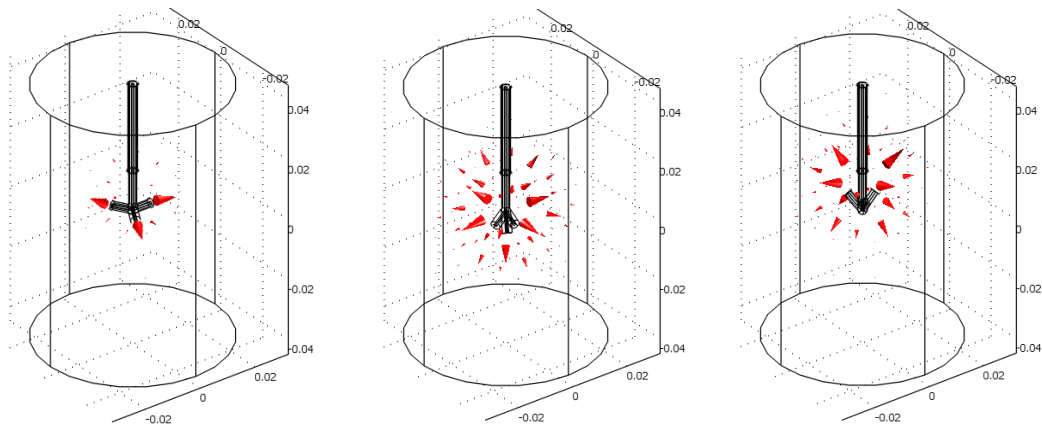

Fig. 3 The heat flux distribution of T-Prong monopole antenna at power of 10W, duration was 300s

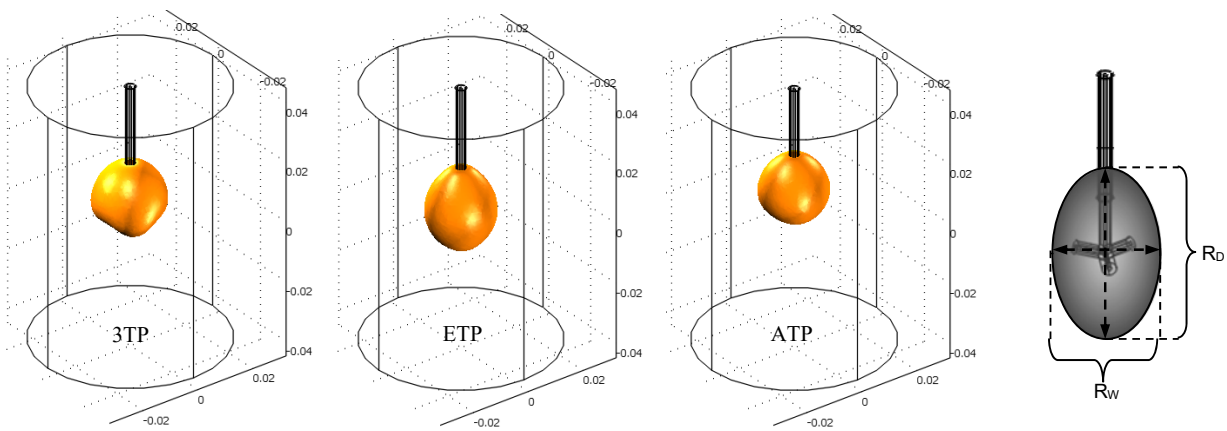

Fig. 4 The lesion zone of T-Prong monopole at power of 10W, duration was 300s

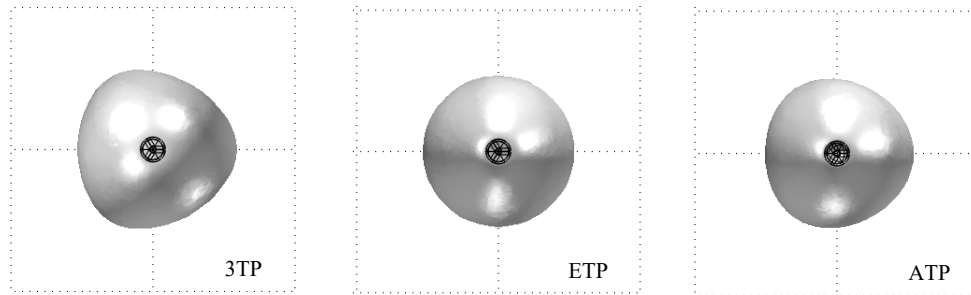

Fig. 5 Lesion pattern on x-y plane, the region where temperature exceeds 50 °C (destruction complete region)

- The potential difference between inner and outer conductors is 10 W and assigns the time of simulation for microwave ablation to be duration time was 300 s.

Then, we performed non-uniform meshing of the geometries using tetrahedral elements. Fig. 2 illustrates the meshed models of the monopole antennas. Table IV lists the numbers of elements and nodes used in three T-Prong monopole antennas models.

III. SIMULATION RESULTS

After we created the geometrical model, generated finite element mesh, and assigned all the material properties and boundary conditions, we ran the coupled electromagnetic-thermal simulations using Comsol.

We then performed post-processing to obtain the heat flux and lesion pattern for different antennas (Figs. 3-5). Lesion width is defined as regions where the tissue temperature is 50°C or above.

TABLE V
THE SIMULATION RESULTS OF T-PRONG ANTENNAS FOR MW ABLATION

Parameter	Antenna type		
	3TP	ETP	ATP
Max temperature (°C)	83.49	79.35	96.71
Thickness (mm)	11.5	10.5	11.5
Lateral (mm)	11.5	13	10.5
Longitudinal (mm)	10	13	10.5
Axial ratio (RW/RD)	1.15	1	1
Ablated Volume (cm ³)	5.48	6.05	4.72

Our simulation result, the T-Prong monopole antenna can be induced the microwave power into the liver cancer, we found that the ATP antenna can induce the temperature within liver cancer was maximized, while the ETP antenna was minimized. The temperature distribution, both antennas (3TP and ATP antenna) occur widest temperature distribution at the T-tip of the antenna, while the ETP antenna was occurring widest temperature distribution at the middle of the antenna.

Lesion pattern or ablation zone, we consider the lesion pattern from axial ratio. The axial ratio equal one (i.e. the ablation zone was a sphere). When the ablated with the ETP and ATP antenna, an ablation zone shows an axial ratio of about 1, while the ablated by using the 3TP antenna, an ablation zone shows an axial ratio about of 1.15 (see in Table IV). In addition, the T-Prong monopole antenna can be induced the microwave power to destruction the liver cancer. The antenna which can be maximized destruction, liver cancer was ETP antenna (about 6.05 cm³).

IV. CONCLUSIONS

In this paper, a new antenna for microwave ablation therapies has been proposed numerical evaluation. We utilized a simulation-based approach to design by using FEM. The various designs for T-Prong monopole antennas were analyzed the heat flux, heating pattern, lesion dimension and ablated volume of all cases. All the antennas have a potential and propagate the microwave power within liver cancer, to create a lesion and destruction the liver cancer. In the future, we shall simulate by performing temperature controlled ablation of 90°C. In addition, we also plan to perform *in vitro* experiments to verify our results from FE analyses.

ACKNOWLEDGMENT

This work is supported by the Thai Research Foundation Grant TRG4580106 and the Biometric for Human Identity Verification Forum, of the Biomedical Engineering Society of Thailand (Thai BMES).

REFERENCES

- [1] M. G. Lubner, C.L. Brace, J.L. Hinshaw and Jr. F.T. Lee, "Microwave tumor ablation: Mechanism of action, clinical results, and devices," *J. Vasc. Intervent. Radiol.*, vol. 21, no. 8, pp. S192–S203, Aug. 2010.
- [2] S. N. Goldberg, "Radiofrequency tumor ablation: Principles and techniques," *Eur. J. Ultrasound*, vol. 13, no. 2, pp. 129–147, Jun. 2001.
- [3] G. Giuseppe D. Costanzo, G. Francica and C. M. Pacella, "Laser ablation for small hepatocellular carcinoma: State of the art and future perspectives," *World J. Hepatol.*, vol. 6, no. 10, pp. 704–715, Oct. 2014.
- [4] C. J. Diederich, W.H. Nau and P.R. Stauffer, "Ultrasound applicators for interstitial thermal coagulation," *IEEE Trans. Ultrason. Ferroelectr. Freq. Control*, vol. 46, no.5, pp. 1218–1228, Sep. 1999.
- [5] R. Tarkowski and M. Rzaca, "Cryosurgery in the treatment of women with breast cancer: A review," *Gland Surg.*, vol. 3, no. 2, pp. 88–93, May 2014.
- [6] P. Wang, C.L. Brace, M.C. Converse and J.G. Webster, "Tumor Boundary Estimation Through Time-Domain Peaks Monitoring: Numerical Predictions and Experimental Results in Tissue-Mimicking Phantoms," *IEEE Trans. Biomed. Eng.*, vol. 56, no. 11, pp. 2634–2641 Nov. 2009.
- [7] M. F. J. Cepeda, A. Vera and L. Leija, "Electromagnetic Hyper-thermia Ablation Devices for Breast Cancer: State of the Art and Challenges for the Future," in *Proc. PAHCE*, 2009, pp. 99–103.
- [8] Y. Chang, W. Che, L. Yang, L. Yang and G. Chen, "Experimental Studies on Microwave Ablation in Vitro Animal Tissues with Microwave Percutaneous Coagulator," in *Proc. ICMMT*, 2008, vol. 4, pp. 1703–1706.
- [9] M. Cavagnaro, A.G. Tuzio and S. Pisa, "The Matching of Microwave Ablation Antennas Through a Semi-Analytic Technique," in *Proc. 40th European Microwave Conf.*, Sept. 28–30, 2010, pp. 220–223.
- [10] Punit Prakash, M. C. Converse, J. G. Webster and D. M. Mahvi, "Design Optimization of Coaxial Antennas for Hepatic Microwave Ablation Using Genetic Algorithms," in *Proc. IEEE AP-S*, Jul. 5–11, 2008.
- [11] A. Karampatzaki, G. Tsanidis, S. Kuhn, E. Neufeld, N. Kuster and T. Samaras "Computational Study of the Performance of Single Applicators and Antenna Arrays used in Liver Microwave Ablation," in *Proc. EUCAP*, 2013, pp.3112–3115.
- [12] Y. Rabin and A. Shitzer, "Numerical solution of the multidimensional freezing problem during cryosurgery," *J. Biomechanical Eng.*, vol. 120, no. 1, pp. 32–37, Feb. 1998.
- [13] K. Saito, Y. Hayashi, H. Yoshimura and K. ITO, 'Heating characteristics of array applicator composed of two coaxial-slot antennas for microwave coagulation therapy', *IEEE Trans. Microwave Theory and Tech.*, 48, pp.1800–1806,2000
- [14] D. Haemmerich, S T. Staelin, J Z. TSAI, S. Tungjitkusolmun, D.M. Mahvi, and J. G. Webster 'In vivo electrical conductivity of hepatic tumours,' *Physiol. meas.*, 24, pp.251–260,2003
- [15] J.D. Kraus and D.A. Flesich, 'Electromagnetics with applications', 5th Edition, McGraw-Hill Company, pp. 389–419,1999

M. Chaichanyut was born in Songkhla, Thailand, on September 20, 1979. He received the B.Eng. and M.Eng. Degrees in Electronics engineering in 2003 and 2005, respectively, from King Mongkut's Institute of Technology Ladkrabang, Bangkok, Thailand, where he is currently working toward the Ph.D. degree in electrical engineering. His current research interests include finite-element modeling, microwave ablation, antenna design, and Power electronics.

S. Tungjitkusolmun (S'96–M'00) was born in Bangkok, Thailand, on December 5, 1972. He received the B.S.E.E. degree from the University of Pennsylvania, Philadelphia, in 1995, and the M.S.E.E. and Ph.D. degrees from the University of Wisconsin, Madison, in 1996 and 2000, respectively. From 2003 to 2007, he was the Assistant Director of Computer Research and Service Center, King Mongkut's Institute of Technology Ladkrabang, Bangkok, Thailand, where he is currently an Assistant Professor with the Faculty of Engineering, Department of Electronics. His current research interests include finite-element modeling, radio frequency ablation, microwave ablation, signal processing, and image processing.