

Comparative Study of IC and Perturb and Observe Method of MPPT Algorithm for Grid Connected PV Module

Arvind Kumar, Manoj Kumar, Dattatraya H. Nagaraj, Amanpreet Singh, Jayanthi Prattapati

Abstract—The purpose of this paper is to study and compare two maximum power point tracking (MPPT) algorithms in a photovoltaic simulation system and also show a simulation study of maximum power point tracking (MPPT) for photovoltaic systems using perturb and observe algorithm and Incremental conductance algorithm. Maximum power point tracking (MPPT) plays an important role in photovoltaic systems because it maximize the power output from a PV system for a given set of conditions, and therefore maximize the array efficiency and minimize the overall system cost. Since the maximum power point (MPP) varies, based on the irradiation and cell temperature, appropriate algorithms must be utilized to track the (MPP) and maintain the operation of the system in it. MATLAB/Simulink is used to establish a model of photovoltaic system with (MPPT) function. This system is developed by combining the models established of solar PV module and DC-DC Boost converter. The system is simulated under different climate conditions. Simulation results show that the photovoltaic simulation system can track the maximum power point accurately.

Keywords—Incremental conductance Algorithm, Perturb and Observe Algorithm, Photovoltaic System and Simulation Results

I. INTRODUCTION

GLOBAL warming and energy policies have become a hot topic on the international agenda in the last years. Developed countries are trying to reduce their greenhouse gas emissions. For example, the EU has committed to reduce the emissions of greenhouse gas to at least 20% below 1990 levels and to produce no less than 20% of its energy consumption from renewable sources by 2020 [1]. In this context, photovoltaic (PV) power generation has an important role to play due to the fact that it is a green source. The only emissions associated with PV power generation are those from the production of its components. After their installation they generate electricity from the solar irradiation without emitting greenhouse gases. In their lifetime, which is around 25 years, PV panels produce more energy than that for their

manufacturing [2]. Also they can be installed in places with no other use, such as roofs and deserts, or they can produce electricity for remote locations, where there is no electricity network.

The efficiency of a PV plant is affected mainly by three factors: the efficiency of the PV panel (in commercial PV panels it is between 8-15% [3]), the efficiency of the inverter (95-98 % [4]-[5]) and the efficiency of the maximum power point tracking (MPPT) algorithm (which is over 98% [6]). Improving the efficiency of the PV panel and the inverter is not easy as it depends on the technology available, it may require better components, which can increase drastically the cost of the installation. Instead, improving the tracking of the maximum power point (MPP) with new control algorithms is easier, not expensive and can be done even in plants which are already in use by updating their control algorithms, which would lead to an immediate increase in PV power generation and consequently a reduction in its price.

MPPT algorithms are necessary because PV arrays have a non-linear voltage-current characteristic with a unique point where the power produced is maximum [7]. This point depends on the temperature of the panels and on the irradiance conditions. Both conditions change during the day and are also different depending on the season of the year. Furthermore, irradiation can change rapidly due to changing atmospheric conditions such as clouds. It is very important to track the MPP accurately under all possible conditions so that the maximum available power is always obtained.

II. PERTURB AND OBSERVE METHOD

The P&O algorithm is also called “hill-climbing”, but both names refer to the same algorithm depending on how it is implemented. Hill-climbing involves a perturbation on the duty cycle of the power converter and P&O a perturbation in the operating voltage of the DC link between the PV array and the power converter [8]. In the case of the Hill-climbing, perturbing the duty cycle of the power converter implies modifying the voltage of the DC link between the PV array and the power converter, so both names refer to the same technique. In this method, the sign of the last perturbation and the sign of the last increment in the power are used to decide what the next perturbation should be. As can be seen in Fig. 1, on the left of the MPP incrementing the voltage increases the power whereas on the right decrementing the voltage increases the power.

Arvind Kumar is with the National Institute of Technology Goa, Ponda-403401, Goa, India (phone: +919405330439; e-mail: arvind20022008@gmail.com).

Manoj Kumar is with the National Institute of Technology Goa, India (phone: +918275621660; e-mail: pooniamanoj27@gmail.com).

Dattatraya H Nagaraj with the National Institute of Technology Goa, India (phone: +918806021531; e-mail: geniusdattu@gmail.com).

Amanpreet Singh is with the National Institute of Technology Goa, India (phone: +919405116836; e-mail: amanpreet_singh75@gmail.com).

Ms. Jayanthi Prattapati is with the department of Electrical and Electronics Engineering, National Institute of Technology Goa, Ponda-403401, Goa, India (phone: +919049544397; e-mail: jayanthip@nitgoa.ac.in).

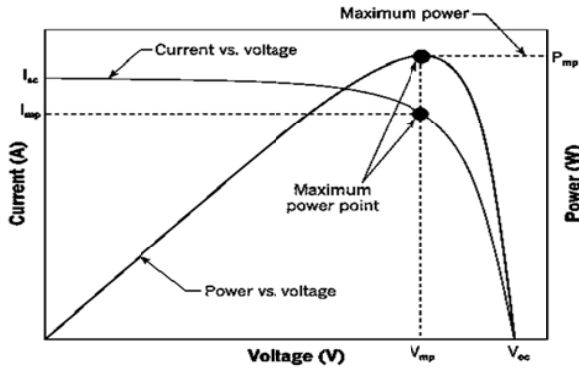

Fig. 1 PV panel characteristics curves

If there is an increment in the power, the perturbation should be kept in the same direction and if the power decreases, then the next perturbation should be in the opposite direction. Based on these facts, the algorithm is implemented [9]. The process is repeated until the MPP is reached. Then the operating point oscillates around the MPP.

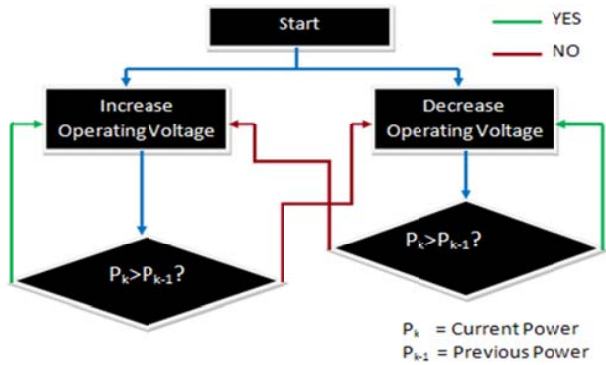

Fig. 2 Flow chart of Perturb & Observation method

The major drawbacks of the P&O method are that the power obtained oscillates around the maximum power point in steady state operation, it can track in the wrong direction under rapidly varying irradiance levels and load levels, and the step size (the magnitude of the change in the operating voltage) determines both the speed of convergence to the MPP and the range of oscillation around the MPP at steady state operation [10], [11].

III. INCREMENTAL CONDUCTANCE METHOD

This method uses the PV array's incremental conductance dI/dV to compute the sign of dP/dV . When dI/dV is equal and opposite to the value of I/V (where $dP/dV=0$) the algorithm knows that the maximum power point is reached and thus it terminates and returns the corresponding value of operating voltage for MPP. This method tracks rapidly changing irradiance conditions more accurately than P&O method. One complexity in this method is that it requires many sensors to operate and hence is economically less effective [12], [13].

We know that:

$$P = V * I \tag{1}$$

Differentiating w.r.t voltage yields;

$$\frac{dP}{dV} = \frac{d(V*I)}{dV} \tag{2}$$

$$\frac{dP}{dV} = I * \left(\frac{dV}{dV}\right) + V * \frac{dI}{dV} \tag{3}$$

$$\frac{dP}{dV} = I + V * \frac{dI}{dV} \tag{4}$$

When the maximum power point is reached the slope $dP/dV=0$. Thus the condition would be;

$$\frac{dP}{dV} = 0 \tag{5}$$

$$I + V * \frac{dI}{dV} = 0 \tag{6}$$

$$\frac{dI}{dV} = -\frac{I}{V} \tag{7}$$

The basic Algorithm of IC is shown in Fig. 3.

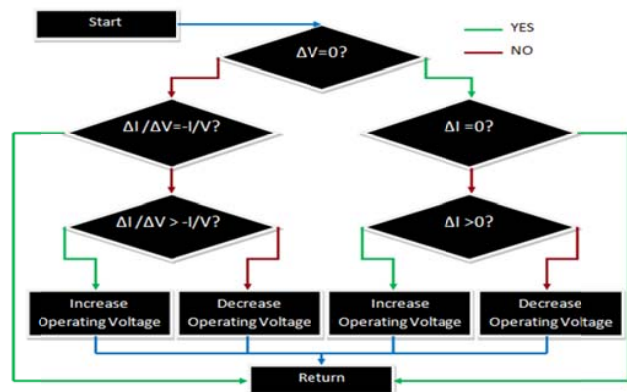

Fig. 3 Flow Chart of Incremental Conductance Method

The drawbacks of these techniques are mainly two. The first and main one is that they can easily lose track of the MPP if the irradiance changes rapidly [13]. In case of step changes they track the MPP very well, because the change is instantaneous and the curve does not keep on changing. However, when the irradiance changes following a slope, the curve in which the algorithms are based changes continuously with the irradiation, so the changes in the voltage and current are not only due to the perturbation of the voltage. As a consequence it is not possible for the algorithms to determine whether the change in the power is due to its own voltage increment or due to the change in the irradiation.

IV. SIMULATIONS AND RESULTS

A. Module Data Sheet and Characteristics

The photovoltaic module used in the simulation of grid connected PV module with IC and P&O as MPPT algorithm

in sections B and C is Canadian Solar CS5P-220M. Table I contains specifications for one module.

TABLE I
MODULE SPECIFICATIONS

Number of series-connected cells	96
Open-circuit voltage V_{oc}	59.2618 V
Short-circuit current I_{sc}	5.09261 A
Voltage at maximum power V_{mp}	48.3159 V
Current at maximum power I_{mp}	4.54758 A

1. I-V and P-V Characteristics of One Module at 25°C

The photovoltaic module Canadian Solar CS5P-220M is simulated for different values of irradiance (kW/m^2). Fig. 4 shows I-V and P-V characteristics of the module for different values of irradiance at constant temperature (25°C).

2. I-V and P-V Characteristics of One Array at 25°C

The photovoltaic array consists of 66 strings of 5 series-connected Canadian Solar CS5P-220M modules, is simulated for different values of irradiance (kW/m^2). Fig. 5 shows I-V and P-V characteristics of the array for different values of irradiance at constant temperature (25°C).

B. Simulation of Grid Connected PV Module with IC as MPPT Algorithm

This simulation uses 100-kW PV array is connected to a 25-kV grid via a DC-DC boost converter and a three-phase three-level Voltage Source Converter (VSC). Maximum Power Point Tracking (MPPT) is implemented in the boost converter by means of a Simulink model using the 'Incremental Conductance + Integral Regulator' technique. PV array used in simulation delivers a maximum of 300 kW at 1000 W/m^2 irradiance as shown in Fig. 6.

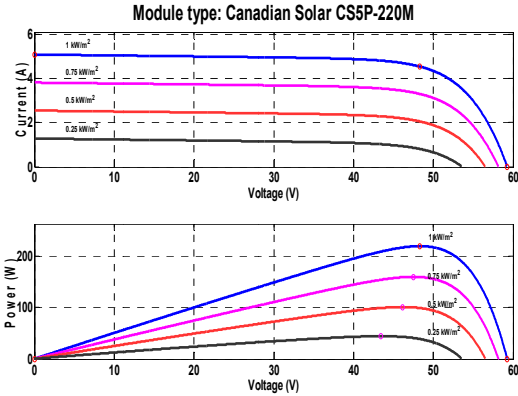

Fig. 4 I-V and P-V Characteristics of One Module at 25°C

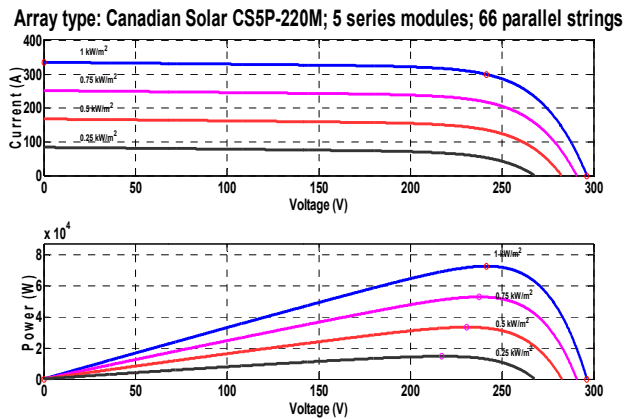

Fig. 5 I-V and P-V Characteristics of One Array at 25°C

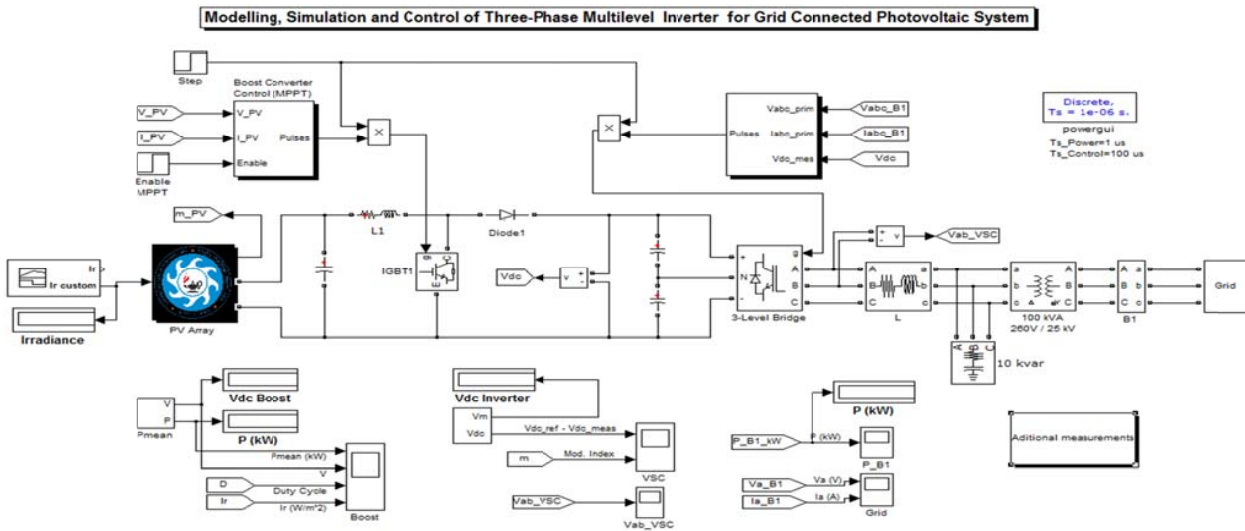

Fig. 6 Simulation of PV Module with IC as MPPT Algorithm

DC-DC boost converter has a frequency of 5-kHz with increasing voltage from PV natural voltage (273 V DC at maximum power) to 500 V DC. Switching duty cycle is optimized by a MPPT controller that uses the 'Incremental

Conductance + Integral Regulator' technique. This MPPT system automatically varies the duty cycle in order to generate the required voltage to extract maximum power.

The VSC converts the 500V DC link voltage to 260V AC and keep unity power factor. The VSC control system uses two control loops:

- external control loop which regulates DC link voltage to +/- 250 V and
- Internal control loop which regulates I_d and I_q grid currents (active and reactive current components).

I_d current reference is the output of the DC voltage external controller. I_q current reference is set to zero in order to maintain unity power factor. V_d and V_q voltage outputs of the current controller are converted to three modulating signals U_{abc_ref} used by the PWM Generator. The control system uses a sample time of 100 microseconds for voltage and current controllers as well as for the PLL synchronization unit. Pulse generators of Boost and VSC converters use a fast sample time of 1 microsecond in order to get an appropriate resolution of PWM waveforms.

PV array used in simulation delivers a maximum of 300 kW at 1000 W/m² irradiance. VSC produces harmonics which is filtered by a 10-kvar capacitor bank, Three-phase coupling transformer has a rating of 100-kVA 260V/25KV .Utility grid has specification of (25-kV distribution feeder + 120 kV equivalent transmission system).

1. Simulation Results of PV Module with IC as MPPT Algorithm

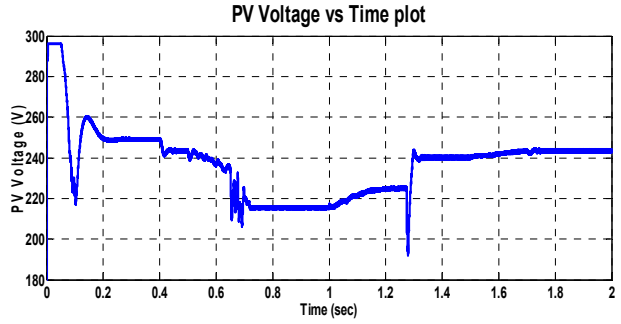

(c)

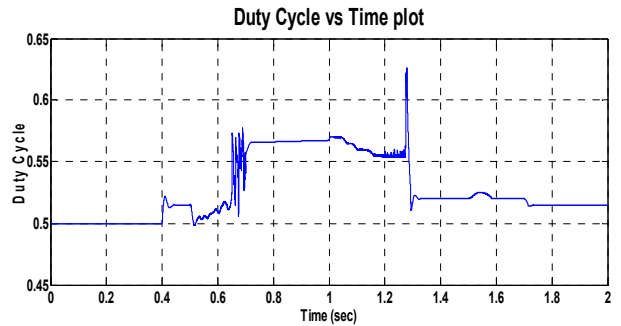

(d)

Fig. 7 (a)-(d) Output at Boost Converter

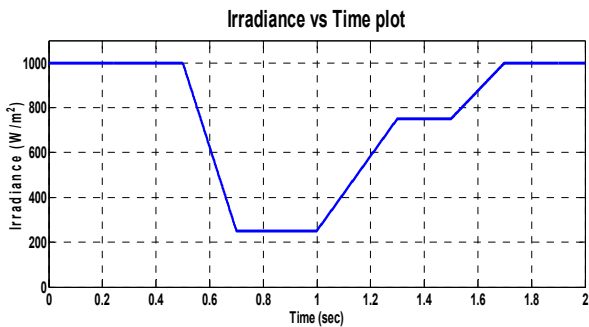

(a)

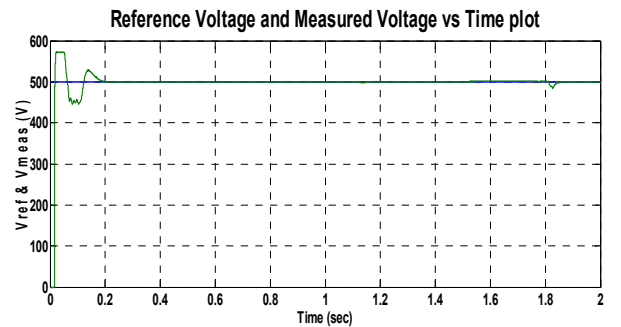

(a)

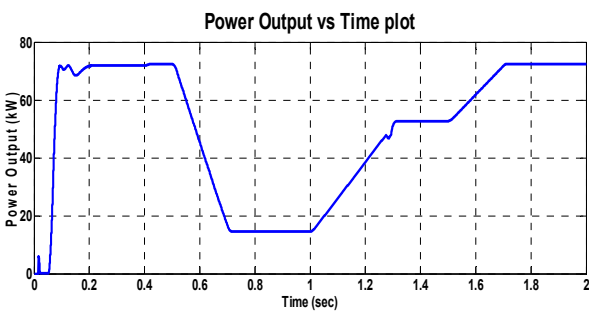

(b)

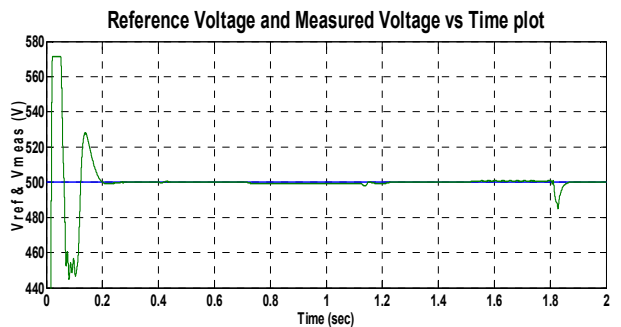

(b)

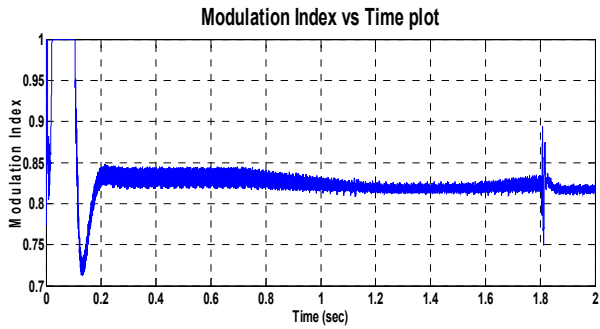

(c)

Fig. 8 (a)-(c) Output of voltage source converter

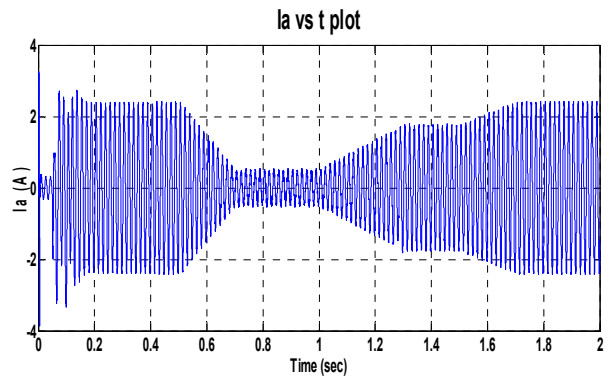

(c)

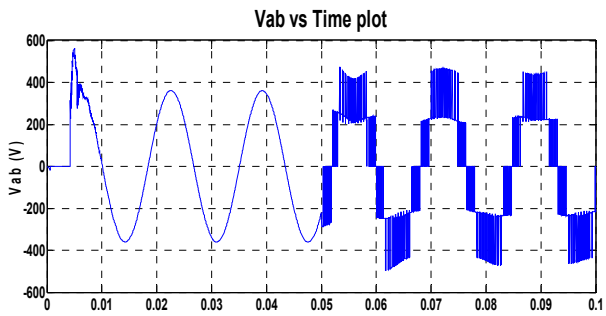
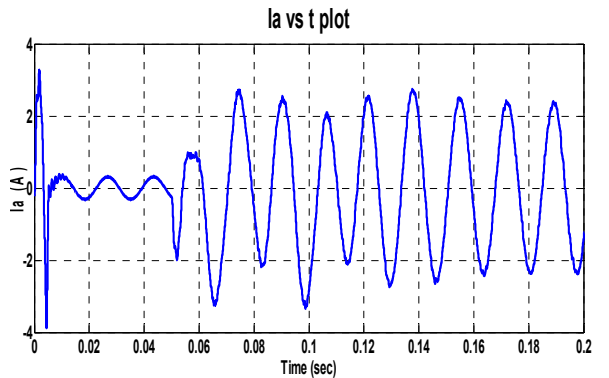
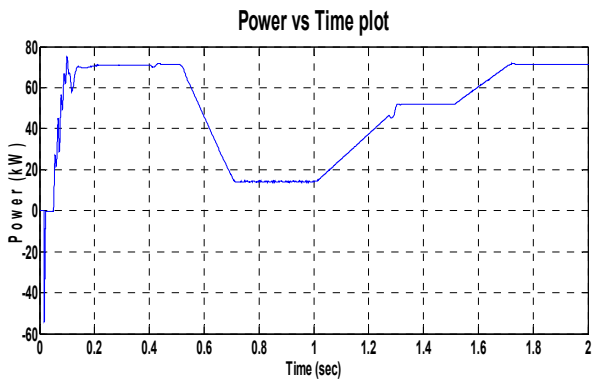

Fig. 9 Output at the inverter



(d)

Fig. 10 (a)-(d) Output at the grid



(a)

C. Simulation of Grid Connected PV Module with P&O as MPPT Algorithm

A 100-kW PV array is connected to a 25-kV grid via a DC-DC boost converter and a three-phase three-level Voltage Source Converter (VSC). Maximum Power Point Tracking (MPPT) is implemented in the boost converter by means of a Simulink model using the 'Perturb & Observe' technique. The average model contains the following components:

- PV array delivering a maximum of 100 kW at 1000 W/m² sun irradiance.
- DC-DC boost converter
- 3-level 3-phase VSC
- 100-kVA 260V/25kV three-phase coupling transformer
- Utility grid (25-kV distribution feeder + 120 kV equivalent transmission systems).

The main difference between the previous model and this model is in the way that DC-DC boost converter and three-phase VSC are modeled. In this model the boost and VSC converters are represented by equivalent voltage sources generating the AC voltage averaged over one cycle of the switching frequency. Such a model does not represent harmonics, but the dynamics resulting from control system and power system interaction is preserved. This model allows using much larger time steps than the detailed model (50 microseconds v/s 1 microsecond), resulting in a much faster simulation. In the IC model the PV-array model contains an

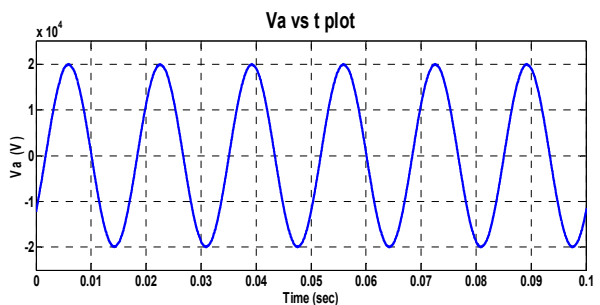

(b)

algebraic loop. This algebraic loop is required to get an iterative and accurate solution of the PV model when large sample times are used. This algebraic loop is easily solved by

Simulink. The 'Perturb and Observe' MPPT algorithm is implemented in the MPPT Control MATLAB Function block.

Modelling Simulation and Control of Three-Phase Multilevel Inverter for Grid Connected Photovoltaic System

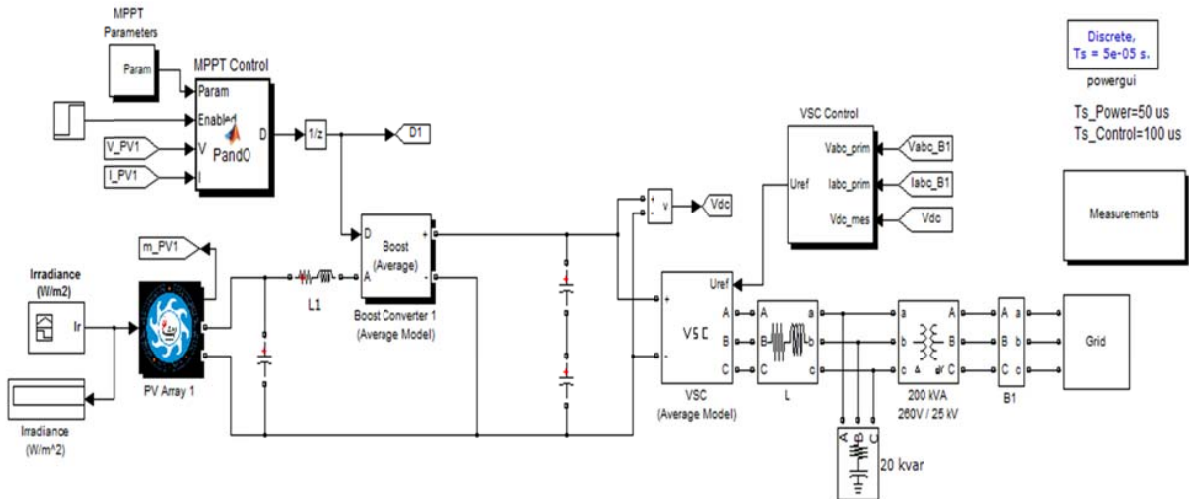
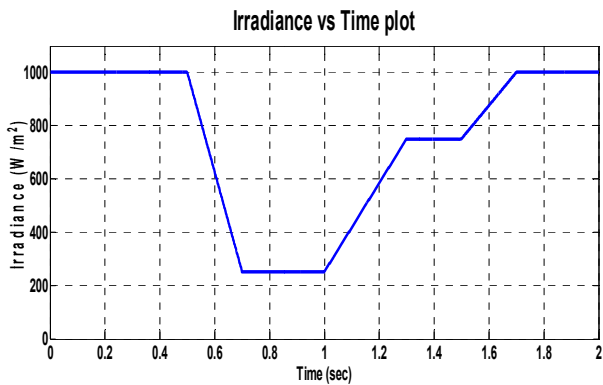
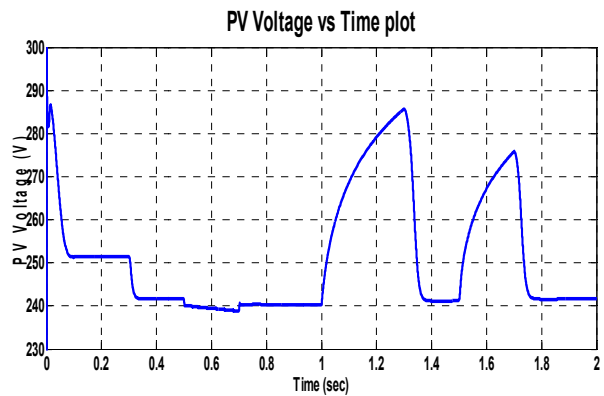

Fig. 11 Simulation of PV Module with P&O as MPPT Algorithm

1. Simulation Outputs of PV Module with P&O as MPPT Algorithm



(a)



(c)

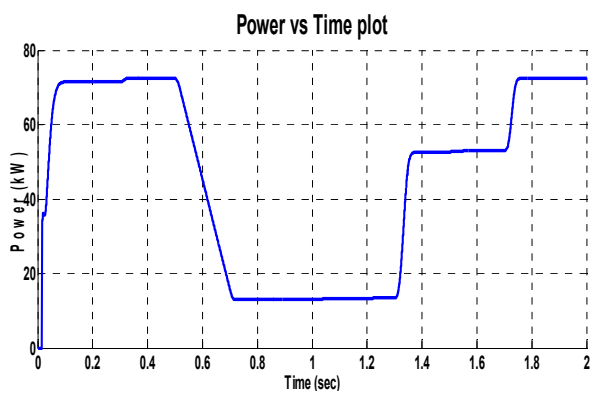

(b)

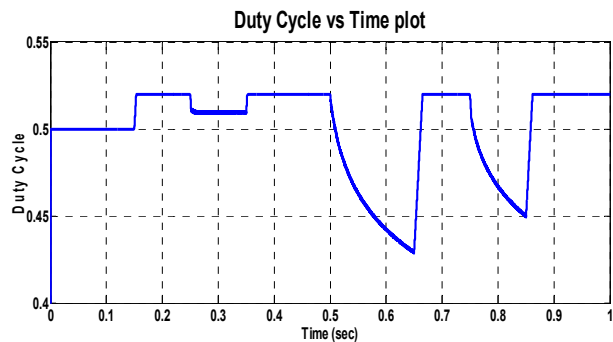

(d)

Fig. 12 (a)-(d) Output at Boost Converter

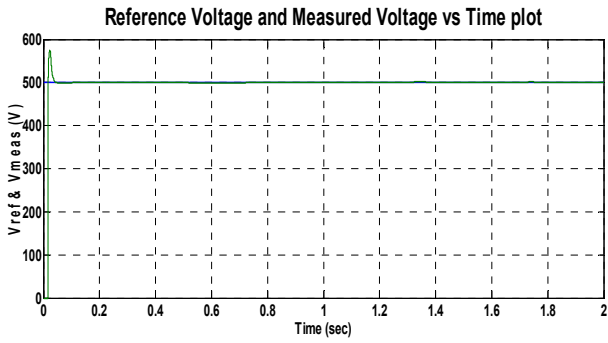

(a)

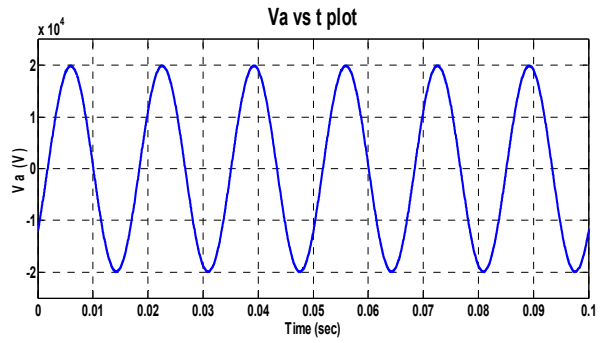

(a)

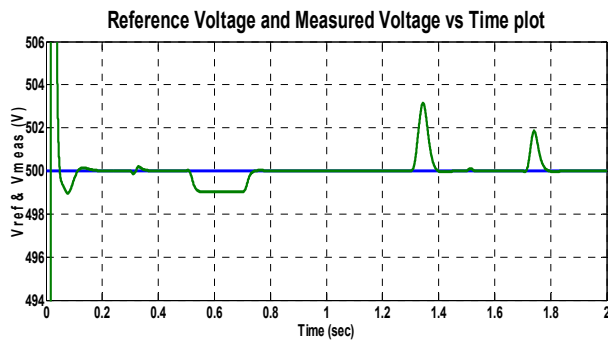

(b)

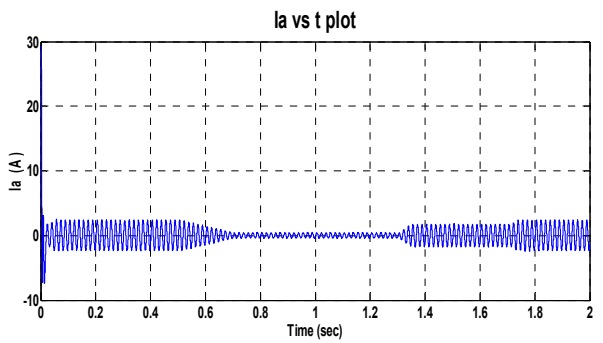

(b)

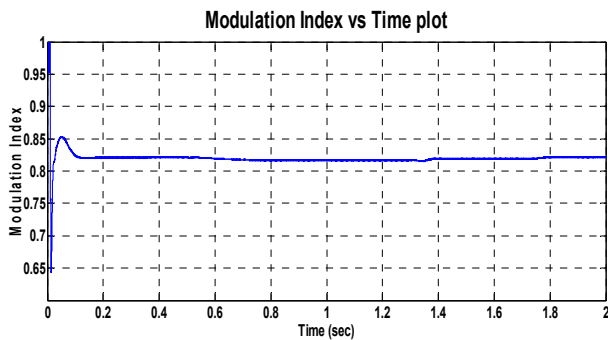

(c)

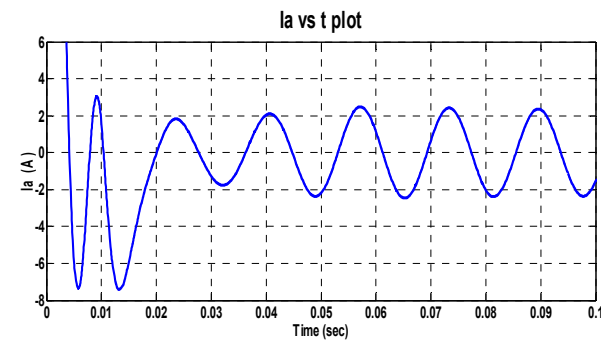

(c)

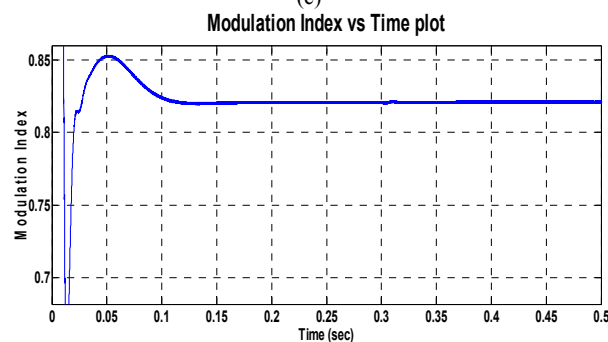

(d)

Fig. 13 (a)-(d) Output of voltage source converter

Fig. 14 (a)-(c) Output at the grid

V. COMPARATIVE STUDY OF RESULTS

A comparative study is performed with IC and P&O MPPT algorithm. The comparisons shown in Fig. 15 shows that with same varying irradiance values the area under the curve in power plot is more in IC than P&O algorithm so more power is generated using IC algorithm than P&O algorithm with same varying irradiance values. In IC Voltage curve settle down fast than P&O. So IC algorithm leads to less settling time.

We thought at the outset of this study that we would find that the perturb-and-observe and incremental conductance algorithms should have very similar overall efficiencies, but that incremental conductance should be slightly better. However, the results of this study indicate that, to within the accuracy available, the MPPT efficiencies of the incremental

conductance and perturb-and-observe MPPT algorithms are essentially the same. When optimized for the particular MPPT hardware in use, P&O and IC had the same performance under clear sky conditions, indicating that the penalty in efficiency caused by the oscillation about the MPP inherent in P&O under steady-state conditions was insignificant for the optimized algorithms. Incremental conductance Outperformed P&O under partly cloudy conditions, as expected, but the difference was very small. Also, interestingly, P&O had a significantly higher efficiency than incremental conductance under cloudy skies.

The results suggest that the simplicity of the P&O algorithm may outweigh any advantage offered by incremental conductance in most applications, particularly low-cost

applications such as module-integrated power electronics. The P&O method can be implemented with fairly simple analog circuitry or a very-low-cost microcontroller. Incremental conductance, on the other hand, requires differentiation, division circuitry and a relatively complex decision making process, and therefore requires a more complex microcontroller with more memory. The choice of which of these two MPP tracking algorithms to use in a PV system can be made by weighing the increased cost of the MPPT to the overall increase of energy produced. This would suggest that an increase in MPPT cost might be justified in a larger PV system, where a small percentage increase in efficiency would lead to a significant increase in energy output.

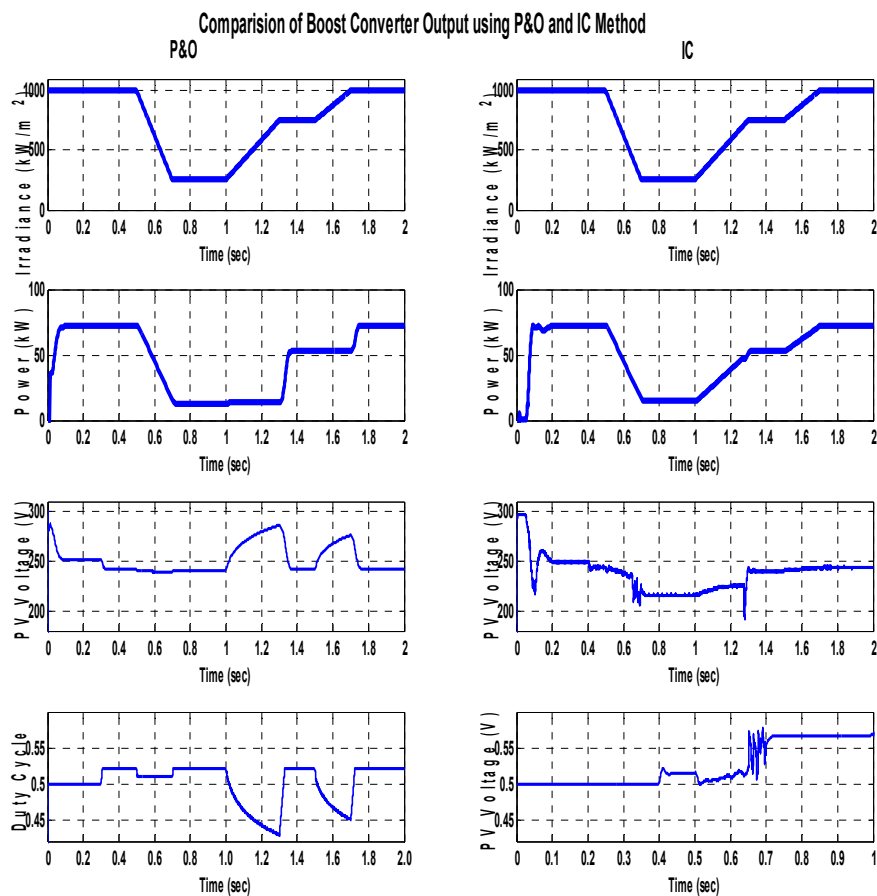

Fig. 15 Comparative Studies of Results

VI. CONCLUSION

This study presents an experimental comparison of the maximum power point tracking efficiencies of two MPPT control algorithms that are discussed in the literature. The scope of the study was limited to those algorithms thought to be applicable to low-cost implementations with currently available hardware. The results suggest that, on the basis of maximum power point tracking efficiency, the Perturb-and-Observe method, already by far the most commonly used

algorithm in commercial converters, has the potential to be very competitive with other methods if it is properly optimized for the given hardware. Incremental conductance performed as well as Perturb-and-Observe method, but in general its higher implementation cost would not be justified by any improvement in performance. Since output voltage using Incremental conductance method varies less in rapidly varying atmospheric conditions and also more power is generated in Incremental conductance algorithm than Perturb-and-Observe

algorithm with same varying irradiance values. Incremental conductance algorithm also has less settling time than Perturb-and-Observe algorithm. Hence Incremental conductance method is found to be more stable than Perturb-and-Observe method.

REFERENCES

- [1] The European Union climate and energy package, (The "20 – 20 – 20" package), http://ec.europa.eu/clima/policies/eu/package_en.htm.
- [2] D. J.C. MacKay, "Sustainable Energy - Without the Hot Air", UIT Cambridge, 2009. (Online). Available: <http://www.inference.phy.cam.ac.uk/sustainable/book/tex/cft.pdf>.
- [3] "Trends in photovoltaic applications. Survey report of selected IEA countries between 1992 and 2009", International Energy Agency, Report IEA-PVPS Task 1 T1-19:2010, 2010. (Online). Available: http://www.iea-pvps.org/products/download/Trends-in-Photovoltaic_2010.pdf.
- [4] P. A. Lynn, *Electricity from Sunlight: An Introduction to Photovoltaics*, John Wiley & Sons, 2010, p. 238.
- [5] "Sunny Family 2010/2011 - The Future of Solar Technology", SMA product catalogue, 2010. (Online). Available: <http://download.sma.de/smapros/dateien/2485/SOLARKATKUS103936W.pdf>
- [6] L. Piegari, R. Rizzo, "Adaptive perturb and observe algorithm for photovoltaic maximum power point tracking," *Renewable Power Generation, IET*, vol. 4, no. 4, pp. 317-328, July 2010.
- [7] N. Femia, G. Petrone, G. Spagnuolo, M. Vitelli, "Optimizing sampling rate of P&O MPPT technique," in *Proc. IEEE PESC*, 2004, pp. 1945-1949.
- [8] T. ESRAM, P.L. Chapman, "Comparison of Photovoltaic Array Maximum Power Point Tracking Techniques," *IEEE Transactions on Energy Conversion*, vol. 22, no. 2, pp. 439-449, June 2007.
- [9] L. Piegari, R. Rizzo, "Adaptive perturb and observe algorithm for photovoltaic maximum power point tracking," *Renewable Power Generation, IET*, vol. 4, no. 4, pp. 317-328, July 2010.
- [10] Murtaza, A.F. ; Fac. of Eng., Univ. of Central Punjab, Lahore, Pakistan ; Sher, H.A. ; Chiaberge, M. ; Boero, D. Comparative analysis of maximum power point tracking techniques for PV applications. *Multi Topic Conference (INMIC), 2013 16th International*.
- [11] Jin-Gook Lee ; Dept. of Electr. Control Eng., Sunchon Nat. Univ., Sunchon, South Korea ; Jae-Sub Ko ; Da-Eun Jeong ; Dong-Hwa Chung, MPPT control of photovoltaic system using the two-mode IC method, *Control, Automation and Systems (ICCAS), 2012 12th International Conference*.
- [12] K.H. Hussein, I. Muta, T. Hoshino, M. Osakada, "Maximum photovoltaic power tracking: an algorithm for rapidly changing atmospheric conditions," *IEE Proceedings on Generation, Transmission and Distribution*, vol. 142, no. 1, pp. 59-64, Jan 1995.
- [13] H. Patel and V. Agarwal : "Maximum Power Point Tracking Scheme for PV Systems Operating Under Partially Shaded Conditions" *IEEE Transaction on Industrial Electronics*, Vol.55, No. 4, pp.1689-1698, 2008.



Arvind kumar was born in Varanasi, Uttar Pradesh, India on 30th October 1992. He is an undergraduate student at Department of Electrical & Electronics Engineering, National Institute of Technology Goa, Ponda, Goa, India. He will receive his B. Tech degree in October 2014. His major fields of interest are power electronics, power systems.

He did a summer internship on Communication and

Safety System in Ships at Goa Shipyard Limited, Goa, India.

Mr. Kumar is a student member of IEEE.



Manoj Kumar was born in Pilani, Rajasthan, India on 1st June 1994. He is an undergraduate student at Department of Electrical & Electronics Engineering, National Institute of Technology Goa., Ponda, Goa, India. He will receive his B. Tech degree in October 2014. His major fields of interest are power electronics and Energy Auditing.

He did a summer internship on PLC & SCADA at NBC

Bearings, Jaipur (Rajasthan) India.

Mr. Manoj is a student member of IEEE.



Dattatraya H Nagaraj was born in Gadag, Karnataka, India on 4th January 1993. He is an undergraduate student at Department of Electrical & Electronics Engineering, National Institute of Technology Goa., Ponda, Goa, India. He will receive his B. Tech degree in October 2014. His major fields of interest are power electronics and Energy Auditing.

He did a summer internship at IFB Verna (Goa), India.

Mr. Nagaraj is a student member of IEEE.



Amanpreet Singh was born in Mumbai, Maharashtra, India on 1st June 1991. He is an undergraduate student at Department of Electrical & Electronics Engineering, National Institute of Technology Goa., Ponda, Goa, India. He will receive his B. Tech degree in October 2014. His major fields of interest are Power systems and Control System.

He did a summer internship on Single Line Diagrams of Industry and CNC Machine at BHEL Punjab, India.

Mr. Singh is a student member of IEEE.



Ms. Jayanthi Prattipati was born in Tenali, Andhra Pradesh, India on 12th Aug 1989. She completed her BE and M.Tech in the years 2010 and 2012 respectively. She has been working in N.I.T Goa to date. Her areas of interest include Renewable Energy Sources, Power Electronics Interface for Renewable energy sources and Power Electronics Applications to Power Systems.