

Computer-Assisted Management of Building Climate and Microgrid with Model Predictive Control

Vinko Lešić, Mario Vašak, Anita Martinčević, Marko Gulin, Antonio Starčić, Hrvoje Novak

Abstract—With 40% of total world energy consumption, building systems are developing into technically complex large energy consumers suitable for application of sophisticated power management approaches to largely increase the energy efficiency and even make them active energy market participants. Centralized control system of building heating and cooling managed by economically-optimal model predictive control shows promising results with estimated 30% of energy efficiency increase. The research is focused on implementation of such a method on a case study performed on two floors of our faculty building with corresponding sensors wireless data acquisition, remote heating/cooling units and central climate controller. Building walls are mathematically modeled with corresponding material types, surface shapes and sizes. Models are then exploited to predict thermal characteristics and changes in different building zones. Exterior influences such as environmental conditions and weather forecast, people behavior and comfort demands are all taken into account for deriving price-optimal climate control. Finally, a DC microgrid with photovoltaics, wind turbine, supercapacitor, batteries and fuel cell stacks is added to make the building a unit capable of active participation in a price-varying energy market. Computational burden of applying model predictive control on such a complex system is relaxed through a hierarchical decomposition of the microgrid and climate control, where the former is designed as higher hierarchical level with pre-calculated price-optimal power flows control, and latter is designed as lower level control responsible to ensure thermal comfort and exploit the optimal supply conditions enabled by microgrid energy flows management. Such an approach is expected to enable the inclusion of more complex building subsystems into consideration in order to further increase the energy efficiency.

Keywords—Energy-efficient buildings, Hierarchical model predictive control, Microgrid power flow optimization, Price-optimal building climate control.

I. INTRODUCTION

SUSTAINABLE development topics and smart energy management recognized energy-efficient buildings as a great money saving opportunity since the sector is one of the world largest energy consumers with heating and cooling processes that consume about 40% world total energy [1]. Large buildings are complex technical systems suitable for sophisticated energy management applications with requirements on dynamic functioning that can be achieved by different system interactions, whereas some of them are more preferable than the others from the standpoints

Vinko Lešić, Mario Vašak, Anita Martinčević, Marko Gulin, Antonio Starčić, Hrvoje Novak are with the Laboratory for Renewable Energy Systems, Department of Control and Computer Engineering, Faculty of Electrical Engineering and Computing, University of Zagreb, Unska 3, HR-10000 Zagreb, Croatia (corresponding author e-mail: vinko.lesic@fer.hr).

of energy consumption or other criteria like price of operation or equivalent pollution, which offer optimization possibilities.

Drastic changes in energy grids are obvious to happen in few years time due to large penetration of dispersed renewable energy sources and new types of consumers like electric vehicles chargers [2]. These changes will most of all be visible in very dynamic shortages and excesses of energy that will have to be balanced in real time. The lack of mature, efficient and accessible large-scale energy storage technologies will require to enforce coordination between dispersed production and consumption points in the grid. The coordination of such legally independent systems will have to be performed on economically sound bases. Buildings are therefore expected to have microgrids consisted of various energy production and consumption units with market bidding participation and dynamic pricing possibility [3].

Especially challenging nowadays becomes to internally manage large consumers in order to benefit from a triplet of grid exchange conditions, environmental conditions and internal states/requirements. The inherent complexity of such systems prohibits to consider all the interactions in a single control problem, such that distributed or hierarchical control approaches stand up-front. Examples of such an integrated control in energy management are by using multi-agent systems [4], Petri nets [5], or model predictive control (MPC) [6]–[16] with the main focus on energy savings in heating and cooling systems based on available future data.

The level of energy consumption in buildings is responsible to achieve proper users comfort in an energy-efficient and cost-optimal way. The level of balancing microgrid power flows between building production, storage and consumption points takes into account the current and near-future: availability of local renewable energy, required consumption, storages state and grid exchange conditions. Thus the actual price of energy consumption to achieve proper comfort heavily depends on the management strategy applied on the power flows balancing level, while that strategy itself depends on the presumed consumption profile.

Commercial buildings today have adopted Building Management System (BMS) as a central and automated control system responsible for coordinating building information network such as: climate control with sensors and heating/cooling units, lighting, fire alarms and other safety systems. The paper describes further utilization of ICT possibilities built on conventional BMS aimed at increasing energy efficiency by means of adapting to external

factors (time of day, weather and ambient temperature) or internal ones (occupancy and people behavior or comfort demands). Possibility of prediction of such phenomena is exploited to find unique energy optimal solution for BMS climate control. Additional savings are ensured by barely noticeable violations of comfort factors in rare high-cost situations. Different sources specify different opportunities of energy-efficient increase by applying ICT extensions to BMS. More conservative ones predict 30% of cost savings while experimentally validated application reached 17% [17]. Considerable decision maneuverability and further contribution is achieved by introduction of microgrid with renewable energy production units and storages, all of which finally leads to economically optimal building climate control, increased efficiency and self sustainability.

Research trends indicate that buildings are expected to have microgrids consisted of various energy production and consumption units with market bidding participation and dynamic pricing possibility [3]. Large possibilities of managing such complex technical systems lie in the utilization of decision making agent formed as an optimization problem divided into several different layers of hierarchy to gain reduced complexity and subsystem independency, where the interoperation with smartgrid is the highest hierarchy level. Information considered the most suitable for exchanging between the building-microgrid-smart grid triplet are hourly energy prices given 24 hours ahead. Utilization of such an accessible information is twofold:

- possibility of finding the economic optimum for building and microgrid management and thus shortening the investment return time and improving the motivation of end users for encompassing the high involvement of renewables and ICT in buildings
- reducing the power grid extremes burden, energy deficits and surpluses, and achieving the match of smart grid production and consumption, buffered through microgrid renewable and storage units, all of which finally leads toward price-controlled hourly consumption profile.

Weather forecast for renewables and heating/cooling demands, comfort demands and occupancy, together with energy price prediction allows determination of power consumption profiles for the next day that acts as a feedback to smart grid decision making. This interoperation is a gateway to consideration of more complex building subsystems and for further increase of energy efficiency.

The paper gives state-of-the-art-overview and comparison of different sub-topics in the area of building climate and microgrid optimization including modeling, predictions, uncertainty handling and controller design. Finally, the principle of hierarchical decomposition of buildings production and consumption systems is exploited and optimal control between the hierarchy levels is applied. Building heating and microgrid systems are observed from the point of highest economical benefit of the building while taking into account internal requirements such as comfort level or production and storage units capabilities. The computed energy consumption profile on the lower level

directly maximizes the global economic gain of the system operation in the presence of system constraints. This enables the proactive role of this large consumer in energy grids of the future. Possibilities of such an approach are illustrated on a case study of two floors of a university building. Observed case can be easily extended to include complete building model and more complex subsystems consideration such as heat pump optimization level or internal microgrid electrical variables interaction, where advantages of hierarchical approach are brought to fore.

The paper is organized in seven sections. After the Introduction, approaches in mathematical modeling of building thermal dynamics, utilization of weather forecast and historical building data are presented in Section II. Microgrid with production and storage units is presented in Section III. Section IV explains MPC problem formulation based on linear program separately for building climate control and microgrid control. Conjoined buildings and microgrid problem and hierarchical decomposition with interaction between hierarchy levels is presented in Section V. Section VI provides simulation results with realistic power flow profiles performed on chosen case study, together with a discussion of further possibilities. Conclusions are finally drawn in Section VII.

II. BUILDING MATHEMATICAL MODELING

Describing the heat transfer throughout the building is largely a concern of mechanical engineering community. Lots of research was put into finding the most physically trustworthy model [18] and various commercial tools are available today for fast extraction of nonlinear mathematical model. Examples of such are *TRNSYS/TRNBuild* [19], *OpenStudio* [20] or *IDA Indoor Climate and Energy* [21]. Besides these physical approaches, modeling can also be performed by using neural networks and historical data or with function approximation etc. but these methods are usually not considered in convex optimization because of high computational requirements and absence of stability guarantee. Detailed database of commercially available building simulation tools is accessible from [22]. Generally, the main prerequisite for such tools is a good knowledge of used building materials, construction characteristics (walls, doors and windows layers, material thickness, areas etc.) and building schematics. However, these parameters are often unreachable and approximate, and model-based control such as MPC require high accuracy of the used model. Additionally, these kind of models are too complex to be used in finding the solution of an optimization problem with large number of zones, especially when ambient climate trends and consumers occupancy is included for reaching the maximum energy efficiency. Therefore, control theory community has put a lot of effort into finding the adequate substitute for physically trustworthy building heat transfer, weather prediction and people behaviour models, which are a good approximation of real system but also of low complexity. Example of the most established approaches are given in the sequel.

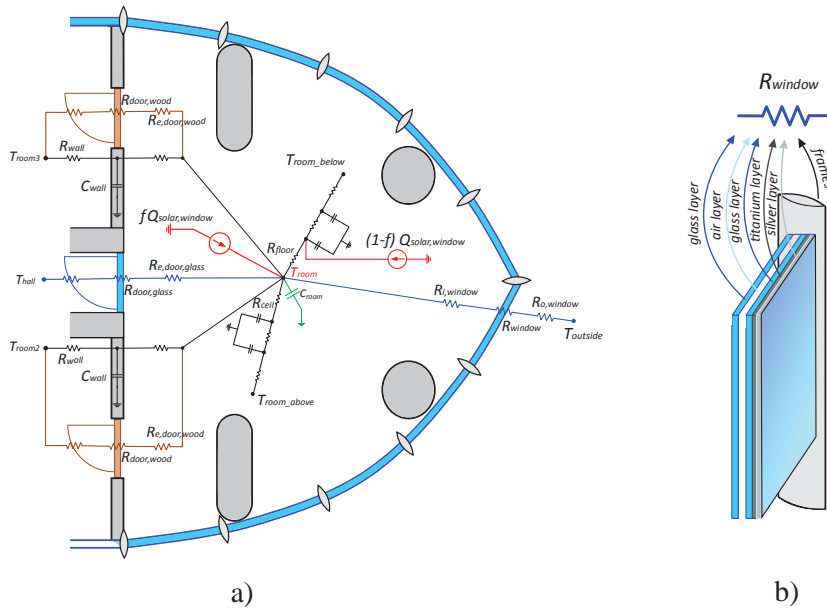

Fig. 1 (a) RC model of an office (b) sketch of window layers and dimensions transferred into a single parameter R_{window} .

A. Zone Modeling

With a goal of model reduction, several rooms were often grouped into larger entities called zones where similar external and internal conditions hold [12]. With the development of embedded computer capabilities and algorithms efficiency, a zone is reduced to a single room where temperature, ambient factors and occupancy are observed separately from other rooms. With different degrees of physicality and complexity, main approaches in modeling are resistance-capacitance (RC) model, simple linear models or parameter-adaptive models.

1) *RC Model*: The most usual approach in thermal modeling of zones is based on linear RC representation where each type of building surface (outside wall, window, inside wall, floor, roof etc.) is represented with one or two states (depending on the heat transfer coefficient). The RC model approach is the most physically valid and captures heat transfer dynamics almost as good as nonlinear, commercial simulation tools. It also results in great number of states per zone and many parameters to be identified. The most significant advantage is that the model is standardized and easily extracted from various thermal model computer-aided software. In addition, the RC approach has high degree of physicality and therefore, if all the heat transfer parameters are known, it is completely determinable in advance (off-line). Examples of RC applications in MPC can be found in [7], [8], [11]–[13], [23].

Fig. 1 (a) shows an exemplary RC model of a commercial building office with outside glass windows and inner narrow separating walls. Mathematical model of the room temperature, which is the central dot of the room in Fig. 1

(a), is in continuous time domain modeled as:

$$\begin{aligned}
 C_{room} \frac{dT_{room}}{dt} = & \frac{2T_{room2}}{R_{wall}} + \frac{2T_{room3}}{R_{wall}} + \frac{T_{room_below}}{R_{floor}} \\
 & + \frac{T_{room_above}}{R_{ceiling}} - \left(\frac{4}{R_{wall}} + \frac{1}{R_{floor}} + \frac{1}{R_{ceiling}} \right) T_{room} \\
 & - \frac{T_{room} - T_{outside}}{R_{i,window} + R_{window} + R_{o,window}} \\
 & - \frac{T_{room} - T_{hall}}{2R_{e,door,glass} + R_{door,glass}} \\
 & - \frac{T_{room} - T_{room2}}{2R_{e,door,wood} + R_{door,wood}} \\
 & - \frac{T_{room} - T_{room3}}{2R_{e,door,wood} + R_{door,wood}} \\
 & + P_{solar>window} + P_{occupancy} + P_{HVAC},
 \end{aligned}$$

where each capacitor from Fig. 1 (a) is also modeled by a differential equation, i.e., the final model of one room contains 7 differential equations or 7 variables in state-space representation. Fig. 1 (b) presents how the parameter R_{window} reflects the summary of thermal conductivities of each layer of material consisting the window. All the other parameters are also calculated in a similar way [18], [24]. Variable $P_{solar>window}$ includes direct and diffuse solar power entered through windows, given as a function of solar radiation $Q_{solar>window}$ and sun position. Consumers behavior is included via predicted parameter $P_{occupancy}$ and reflects the people contribution (e.g. body heat or office computer usage) to the power flow balance. Power P_{HVAC} is the heating/cooling power inserted into the room by a climate actuator, e.g. Heating, Ventilation and Air Conditioning unit (HVAC), supply air tube or ventiloconvectors. The P_{HVAC} is also the control variable given from the power optimization algorithm.

As stated before, the main disadvantage are tentatively known parameters in practice and large order of the model itself when it is augmented for each room of the building. There is an extensive literature with many different approaches on how to perform order reduction of linear time invariant systems. These approaches include singular value decomposition methods, moment matching methods, Krylov subspace based techniques, balanced model reduction approaches, etc. [25]. One of the most common methods for model reduction is based on Hankel singular values, which provide a measure of energy for each system state. States with relatively small Hankel singular values can be safely discarded [26], [27]. Example of applying the Markov chains theory for reducing the order of the building model is given in [23]. Although this method retains the physicality of the model, it is computationally consuming and the final problem is non-convex, i.e., the optimality is not guaranteed. The main disadvantage of most available methods is in the fact that by reducing the order of the model its physicality is lost.

2) *Semi-Physical Models*: Although the accuracy of linear RC model is satisfactory, the underlying detailed modelling results in high order model. Model predictive control optimization problem with 24 hours prediction horizon and high order model can be computationally too intensive and in a worst case can remain unresolved due to the lack of memory required to solve it. This problem is especially evident in advanced MPC approaches such as stochastic MPC [11], [13]. One solution to obtain model applicable for MPC is to use the model order reduction methods as described in the previous section. Another approach is to use the available historical data for getting an applicable model for control system design. Unscented Kalman Filter (UKF) is a well-known estimation technique for nonlinear state and parameter estimation [28]. The main premise behind the UKF estimation principle is that it is easier to approximate a Gaussian distribution than an arbitrary nonlinear function. Use of UKF for estimation of building parameters was already reported in [14], [29]. In standard RC approach, building zone is described using minimum 7 capacities (6 for walls and one for representation of air inside a zone) which results with a zone model of a minimum 7th order. By observing the time constants of building thermodynamic processes it is evident that the dominant time constants are related to the air temperature of the zones. Other, noticeably larger time constants, are related to walls or additional internal masses (like furnishing) due to their higher thermal capacity. Thus, the zone thermodynamic is approximated with two thermal masses: **fast dynamic** with lower thermal capacity related to the air temperature inside a zone and **slow dynamics** with a higher thermal capacity related to the solid zone parts (walls and furnishing) [9]. This approach is somewhere in-between regarding the physicality and complexity when compared to previous two. Great advantage is that parameter-adaptation is performed on-line and captures the variable phenomena such as people behavior or system changes over time.

3) *Simple Linear Model*: The simplest possible models, and the farthest ones from the real system physicality are those grounded on well established control theory basics used in

wide areas of application, from process industry to image recognition. One of the more elaborate approaches in this area is usage of autoregressive-moving-average model (ARMAX), example of which can be found in [6], [9], [10], [30]. General representation of such model in discrete time domain (for time instant k) is:

$$\mathbf{A}(q)T_{room}^k = \mathbf{B}(q)T_{HVAC}^k + \mathbf{C}(q) \begin{bmatrix} T_{outside}^k \\ I_{solar,window}^k \\ T_{occupancy}^k \end{bmatrix}, \quad (1)$$

where $\mathbf{A}(q)$, $\mathbf{B}(q)$ and $\mathbf{C}(q)$ are polynomials that determine the system dynamics, T_{HVAC} is the airflow temperature of climate actuator, $I_{solar,window}$ is the solar influence on the room and $T_{occupancy}$ is the temperature influenced by consumer behavior.

The main disadvantage is that the model has to be identified, i.e., polynomials $\mathbf{A}(q)$, $\mathbf{B}(q)$ and $\mathbf{C}(q)$ are required to be determined. This can only be performed on historical data and, for a trustworthy model, one year of hourly data records for each variable from (1) is a prerequisite. Because of the model distance from the real system physicality, all of the uncertainty and unidentified disturbances are then transferred to the probability problem and stochastic representation, which will be discussed later.

B. Weather Forecast

Weather forecast plays important role in MPC for buildings. The weather forecast data comprise from the outside air temperature and the incoming diffuse and direct solar radiation. The information about diffuse and direct solar radiation is very important since they affect external building areas in different ways. The overall solar radiation gain in some zone depends on site-specific factors: window glazing area, window tilt angle, glazing type, geographic location and orientation of the building, shading factors and Sun inclination angle. Coefficient for calculation of overall zone solar gain is calculated from the knowledge of the window property called Solar Heat Gain Coefficient (SHGC) [24] or simply estimated within estimation procedure.

C. Comfort Demands and Constraints

Comfort demands are key task to be obeyed and they determine how much energy is possible to be saved in given ambient conditions. Small residential buildings have freedom of setting the temperature level as desired while large commercial buildings have central unit responsible for maintaining pre-defined zone temperature, which usually leads to higher energy efficiency. Temperature comfort to be respected by the optimization problem is formed as state constraints for each individual room:

$$T_{min} \leq T_{room} \leq T_{max}, \quad (2)$$

where T_{min} and T_{max} are the minimum and the maximum temperatures that bound the comfort span (e.g. from 20°C to 24°C). According to [31], temperature constraints are acceptable to be violated for a short period of time, which gives additional space for energy saving in extreme situations.

Limitation in heating/cooling of a room is set by actuator restrictions. Power of HVAC or ventiloconvectors is included in the optimization problem via power constraint:

$$P_{HVAC,min} \leq P_{HVAC} \leq P_{HVAC,max}. \quad (3)$$

D. People Behavior

Modeling of people behavior is the most challenging task. However, clear and reliable knowledge of occupancy information during working hours is available for offices and commercial buildings. People tend to behave in patterns during working days and this information is too valuable to be discarded or treated like an uncertainty. So far, simple presence detection has been included in optimization problems [8], [15], [32] for relaxing the comfort constraints. In [9], the ARMAX model was again applied on collected measurements of people occupancy influence on temperature trends in university library and exploited for reaching the maximum efficiency with MPC. Sudden CO₂ changes are also a valuable information to be used for occupancy detection in offices and smaller zones if such sensors are available.

E. Uncertainty

1) *Gaussian Approximation*: The most common approach in treating the uncertainty is the Gaussian approximation of unknown influences. With high degree of model physicality, some unknown parameters are well captured this way. Gaussian approach has proven very successful in capturing the uncertainty effects of weather forecast [11] and microgrid production units [33], but is problematic for occupancy disturbance [9]. Uncertainty is described with known probability density function:

$$f_X(\mu, \sigma) = \frac{1}{\sigma\sqrt{2\pi}} e^{-\frac{(x-\mu)^2}{2\sigma^2}}, \quad (4)$$

and known cumulative density function:

$$\Phi(x) = \int_{-\infty}^x f_X(t) dt, \quad (5)$$

and finally included in the optimization problem as chance constraints:

$$\mathbb{P}(Gx \leq w) \geq 1 - \alpha, \quad (6)$$

where user-defined parameter α denotes probability that the constraint is violated. If (6) is put into equivalent form of:

$$w - Gx \geq \Phi^{-1}(1 - \alpha) \|\sigma x\|_2, \quad (7)$$

the problem formulation becomes deterministic and more easily handled in the optimization problem.

2) *Scenario-Based Approach*: In most occasions uncertainty that influences the optimization problem falls out of category of known distributions, which causes deviation from optimum solution and loss of stability guarantee. This is especially expressed in low physicality models such as ARMAX, which deviate more from optimum solution due to less modeled phenomena. Here, so-called scenario-based approaches are used to capture the unknown distribution with examples given in [6], [9], [10], [16]. Instead of

finding distribution function for the observed problem, large number of identically distributed and independent disturbance samples, called scenarios, are generated and observed. Similar approaches are used in weather forecast state-of-the-art, called ensemble prediction methods [34]. This way linear programming is maintained but with increased number of linear constraints, which sufficiently well capture the disturbance distribution. Instead of large number of linear constraints, only the worst scenarios can be observed [16], which simplifies the calculation thoroughly and reduces the number of constraints to two: min and max. In return, it also results in conservative control law that reduces the possible feasible solutions bringing the solution very close to that of the robust MPC approach. As a trade-off between computational burden and conservatism, it is possible to reduce number of samples and constraints while keeping the control law less conservative in an optimal sample removal scenario performed at each time instant [9], sometimes referred to as optimal risk allocation.

III. MICROGRID MATHEMATICAL MODELING

Microgrids or building-size smart grids are expected to become an active part of the power system that enables decentralization of power system, thus increasing its reliability and stability [35]. Because of the economic and environmental benefits that stem from the optimal microgrid power flow, considerable attention is directed to development of better optimization algorithms and suitable modelling frameworks [36]. Examples of MPC used in experimentally validated environment on residential microgrid are [37] and [38]. Challenges and future trends for renewable energy production and storage units used in microgrids and smartgrids are elaborated in [39]. In the sequel, the most common components, technical limitations and power flows are explained on the example of a 48 V DC microgrid.

A. Microgrid Components

Exemplary DC microgrid from Fig. 2 operates at 48 V [40]. It consists of the following systems for generation or storage of electrical energy: (i) a photovoltaic array, (ii) a small-scale wind turbine emulator, (iii) a supercapacitor, (iv) a valve-regulated lead-acid (VRLA) batteries stack, and of (v) an electrolyzer with fuel cells stack.

1) *Production Units*: **Photovoltaic (PV) array** includes eight poly-Si PV panels that are arranged in two equal parallel branches, and are mounted on a dual-axes positioning system for power production maximization [41]. Performance of the PV array under standard test conditions¹ (STC) is as:

$$P_{MPP} = 1520 \text{ Wp}, \quad V_{OC} = 119.2 \text{ V}, \quad I_{SHC} = 16.7 \text{ A}, \quad (8)$$

where P_{MPP} is PV array power at maximum power point (MPP), while V_{OC} and I_{SHC} are PV array open-circuit (OC) voltage and short-circuit (SHC) current at STC.

¹Standard test conditions (STC) usually assume 1000 W/m² incident solar irradiance, 25 °C PV panel temperature, and 1.5 air mass index.

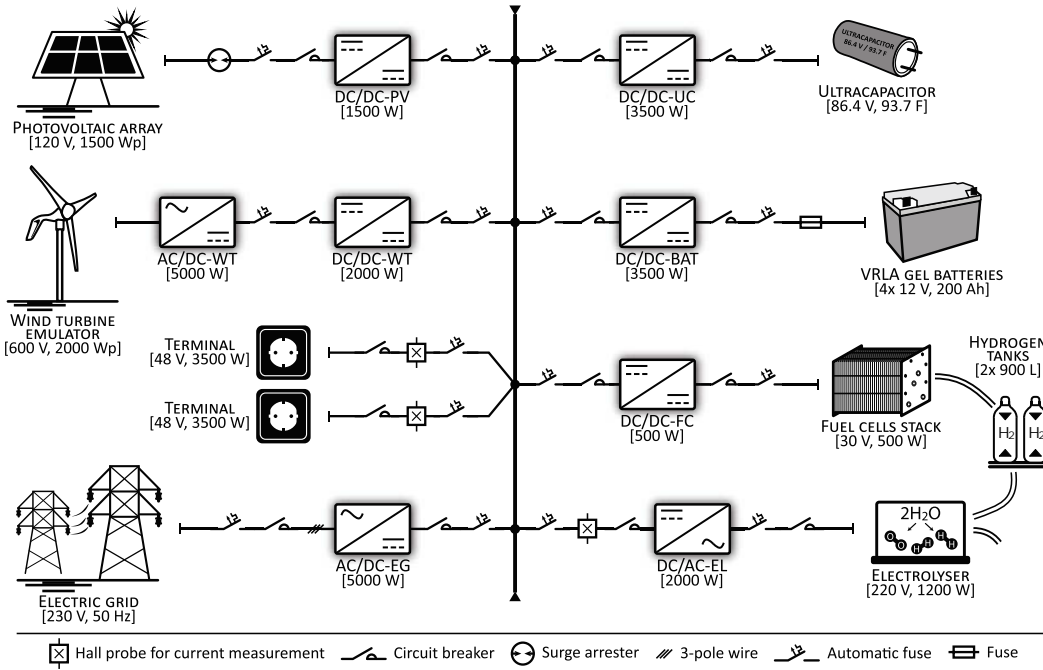

Fig. 2 Schematic diagram of an exemplary 48 VDC microgrid

Photovoltaic array power production is calculated in discrete time step k based on measured solar irradiance and temperature data via simple power production model [42]:

$$P_{PV}^k = \theta_1 Q_{PV}^k + \theta_2 T_{PV}^k + \theta_3 G_{PV}^k T_{PV}^k, \quad (9)$$

where Q_{PV}^k and T_{PV}^k are incident solar irradiance and temperature, and θ_1 , θ_2 and θ_3 are the PV array model parameters.

Small-scale wind turbine (WT) with horizontal axis has two operating regions: below rated wind speed region where all the available wind power is captured and transferred to electricity, and above rated wind speed region in which the power production is saturated at the rated power with passive mechanisms for reduction of blades aerodynamical properties (flaps, breaks etc.). Usually the wind is stronger during the night, which complements the photovoltaic power production. The wind is also highly dynamical stochastic renewable that makes it hard to predict the WT power output. Wind turbine power production model is given with [45]:

$$P_{WT}^k = \frac{1}{2} \rho_{air} R^2 \pi C_P(\lambda, \beta) (V^k)^3, \quad (10)$$

where ρ_{air} is the air density, R is the radius of blade disc, C_P is the power coefficient that reflects the aerodynamical property, dependent of so-called tip-speed-ratio λ and blade aerodynamical property β . Power production is determined from the meteorological data and wind speed V predictions.

2) **Energy Storage: Supercapacitor (SC)** or ultracapacitor is a high-capacity electrochemical capacitor with typical storage of 10 to 100 times more energy per unit volume or mass than electrolytic capacitors, and can accept and deliver charge much faster than batteries. Observed supercapacitor has 93.7 F capacitance and 86.4 V open circuit voltage when it

is fully charged. Due to the power converter limitation on input voltage range, the supercapacitor lower voltage is set to 35 V, which gives approximately 81.2 Wh usable energy, i.e., supercapacitor can be fully charged or discharged at full power converter rate (3.5 kW) within 83 s. Supercapacitor is modeled as a discrete-time first-order difference equation with a sampling time T_s :

$$x_{SC}^{k+1} = x_{SC}^k - \eta_{SC} T_s P_{SC}^k, \quad (11)$$

where x_{SC} is the supercapacitor state-of-charge, η_{SC} is the efficiency of charging power P_{SC} .

VRLA batteries stack includes four VRLA gel batteries connected in series with following performance characteristics:

$$V_{OC,n} = 48 \text{ V}, \quad C_{10} = 200 \text{ Ah}, \quad (12)$$

where $V_{OC,n}$ is nominal open-circuit voltage, and C_{10} is the capacity when the batteries stack is discharged in 10 hours.

Batteries are also modeled as a discrete-time first-order difference equation:

$$x_{BAT}^{k+1} = x_{BAT}^k - \eta_{BAT} T_s P_{BAT}^k, \quad (13)$$

where state x_{BAT} is the battery state-of-charge (SoC), and η_{BAT} is the battery charging or discharging efficiency that depends on the sign of power P_{BAT} [33], [43].

Fuel cells (FCs) stack includes 32 proton exchange membrane (PEM) fuel cells connected in series, with electrolyzer (rated power 1200 W) for on-site hydrogen production and with two metal hydride tanks (overall storage capacity 1800 L) for hydrogen storage. Performance of FCs stack is as:

$$P_{FC} = 500 \text{ W}, \quad V_{FC} = 30 \text{ V}, \quad I_{FC} = 30 \text{ A}, \quad (14)$$

where P_{FC} , V_{FC} and I_{FC} are FCs stack maximum power, voltage and current, respectively.

Note that FCs stack with electrolyzer can be considered as an energy storage system, since electrolyzer produces hydrogen when there is excess power, while FCs use this stored hydrogen when there is power shortage. This system is also modeled by using first order difference equation:

$$x_{FC}^{k+1} = x_{FC}^k - \eta_{FC} T_s P_{FC}^k. \quad (15)$$

3) *Power Converters*: Power converters are critical components of microgrids. They are used for balancing different levels of voltage or AC and DC conversion. Since the DC bus is maintained at 48 V, all the production units, storages and loads have to be converted to this level. Power converters represent control points that, by proper operation, assure overall system stability and quality of power supply.

There are three main kinds of DC/DC converters: buck converter denotes that output voltage is lower than input, boost converter is for the case when output voltage is higher than input and buck-boost converter denotes that output voltage can both be higher or lower than the input voltage.

Considered DC microgrid includes the following power converters:

DC/DC-PV. DC/DC (buck) converter for PV array connection. Converter operates in voltage mode control and has a built-in control loop for input current. Input current reference is issued to the converter via analog signal 0–20 mA.

DC/DC-BAT. DC/DC bidirectional (buck-boost) converter for VRLA batteries stack connection. Converter operates in voltage mode control, and has a built-in control loop for input current (batteries stack side current). Input current reference is issued to the converter via analog signal 0–20 mA.

DC/DC-FC. DC/DC (boost) converter for FCs stack connection. Converter operates in current mode control, i.e. converter control variable is peak inductor current, and has a built-in control loop for input current. Input current reference is issued to the converter via analog signal 0–20 mA.

DC/AC-EL. DC/AC (single-phase) converter for electrolyzer connection. Converter operates completely autonomously without possibility for external control inputs.

DC/AC-EG. DC/AC bidirectional (three-phase) converter for electrical grid connection. Converter has a built-in control loop for input current (DC side current). Input current reference is issued to the converter via serial RS-485 communication using MODBUS protocol.

B. Constraints

To prevent permanent damage of microgrid components, they must be kept within the usual operating values. Supercapacitor constraints are described with:

$$0 \leq x_{SC}^k \leq C_{SC}, \quad (16a)$$

$$-P_{SC}^{\max} \leq P_{SC}^k \leq P_{SC}^{\max}, \quad (16b)$$

where C_{SC} is the capacity, and P_{SC}^{\max} is the supercapacitor power converter limitation.

Battery SoC x_{BAT} and power P_{BAT} always must be inside their limits to avoid irreversible capacity loss:

$$0.2C_{BAT} \leq x_{BAT}^k \leq C_{BAT}, \quad (17a)$$

$$-P_{BAT}^{\max} \leq P_{BAT}^k \leq P_{BAT}^{\max}, \quad (17b)$$

where C_{BAT} is the battery capacity, and P_{BAT}^{\max} is the battery power converter limitation.

Fuel cells technical limitations are defined with:

$$0 \leq x_{FC}^k \leq C_{FC}, \quad (18a)$$

$$P_{FC}^{\min} \leq P_{FC}^k \leq P_{FC}^{\max}, \quad (18b)$$

where P_{FC}^{\min} is the FC power converter limitation, and P_{FC}^{\max} is the electrolyzer power limitation.

Grid power converter technical limitations are defined with:

$$-P_{EG}^{\max} \leq P_{EG}^k \leq P_{EG}^{\max}. \quad (19)$$

C. Power Profile Prediction

When operating in grid-connected mode, the microgrid can import/export energy from/to the utility grid through the grid-tied bidirectional power converter. A decision when to buy and sell energy to the utility grid and in which amount, i.e., when to charge and discharge storages, is a complex function of the predicted microgrid load P_L [44], power production (renewables), and of the current storages state-of-charge (SoC). This function is also subject to various constraints like energy storages capacity, power converters power ratings, and even to utility grid possibly reduced availability [33], [43].

Photovoltaic power profile is forecasted from available solar inclination predictions (9) and wind turbine power is forecasted from future wind predictions (10). Both sources are subject to weather forecast uncertainty and are treated the same way as in buildings case – Gaussian distribution for solar inclination and wind predictions.

IV. ENERGY-OPTIMAL CONTROL

A. Building Climate Optimal Control

Total summary of considered elements to be included in optimization problem is illustrated in Fig. 3. Naturally, not all of them are imperative and larger energy efficiency is obtained with higher degree of considered details. Mathematically, this is expressed in the form of constrained linear program as:

$$J^*(u) = \min_u \sum_{k=0}^N f^T u, \quad (20a)$$

subject to :

$$x_{k+1} = \mathbf{A}x + \mathbf{B}_u u + \mathbf{B}_d d, \quad (20b)$$

$$\mathbf{G}_x x \leq w_x, \quad (20c)$$

$$\mathbf{G}_u u \leq w_u, \quad (20d)$$

where x is the state vector (capacitances of RC model for each zone), u is the control variable vector (vector of P_{HVAC} for each zone), d is disturbance vector (solar radiation, ambient

temperatures and occupancy), \mathbf{A} , \mathbf{B}_u and \mathbf{B}_d are matrices derived for the building model (??) discretized with sample time T_s . Equation (20c) is for comfort constraints from (2) and can optionally be put in the probabilistic form from (6). Equation (20d) covers actuator constraints from (3).

Problem solving is performed with convex optimization linear program solvers and yields the optimum U^* consisted of control vectors for each zone and each time step, from current one to the end of horizon N . Finally, control variable passed to the building climate actuators is the current step one, $U_{k=0}^*$, and the procedure is again performed when the following time instant occurs.

B. Microgrid Optimal Control

Total summary of microgrid considered elements to be included in power flow optimization problem is illustrated in Fig. 4. Again, larger microgrid energy efficiency is obtained with higher degree of considered details. Mathematically this is also represented with (20), where now x is the state vector of storage states, u is the control variable vector consisted of storage units charge/discharge powers (P_{SC} , P_{BAT} and P_{FC}) and utility grid power P_{EG} calculated as a power flow balance:

$$P_{EG}^k = P_L^k - P_{WT}^k - P_{PV}^k - P_{SC}^k - P_{BAT}^k - P_{FC}^k. \quad (21)$$

Disturbance vector d consists of photovoltaics and wind turbine power production profiles. Matrices \mathbf{A} , \mathbf{B}_u and \mathbf{B}_d are derived from the microgrid model (11), (13) and (15). Equation (20c) is set to keep the storage units within designated capacity, (16a), (17a) and (18a). Equation (20d) covers power converter constraints from (16b), (17b), (18b) and (19).

Solution of the solved problem here yields the optimum U^* consisted of control vectors for each power converter for storages over the horizon of N . Again, only the current step one, $U_{k=0}^*$, is applied as the reference passed to power converters and the problem is solved again for the next time step.

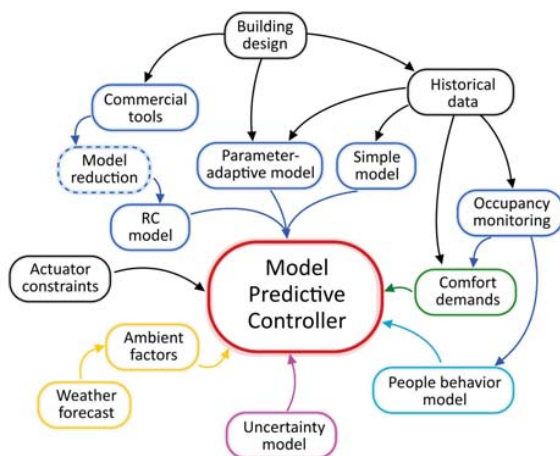

Fig. 3 Summary of components taken into account for building climate model predictive controller synthesis

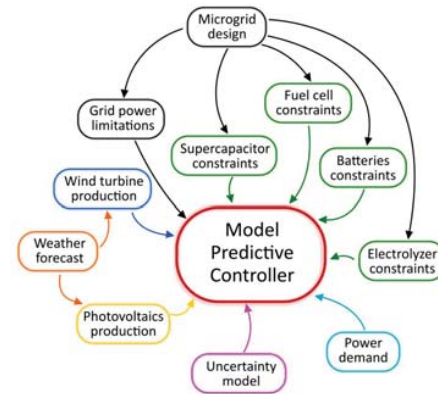

Fig. 4 Summary of components taken into account for microgrid power flow model predictive controller synthesis

V. PRICE-OPTIMAL CONTROL

A. Real-Time Pricing

Real-time pricing (RTP) is becoming an emerging research and implementation topic in energy market [46], [47]. It refers to usage of smart meters and hourly based prices on consumer levels. While RTP is very common in industry, USA and some European countries already provide such a possibility for commercial or residential buildings and it is expected to widely spread among the consumers. In practice, this opportunity is not exploited due to lack of proper decision making algorithm for power shifting and cost savings. Presented climate and microgrid power flow optimization based on MPC inherently covers such a scenario, which provides larger opportunities for cost savings. This opportunity shifts the building and microgrid management from energy-optimal to price-optimal control, which are not necessarily coincided due to variations in market prices. Additionally, smart and energy efficient building with included such a control is suitable to directly participate in market bidding.

B. Microgrid and Buildings Unified Problem Formulation

Overall goal and optimization criterion is the maximum economical gain of the smart building as a closed system, i.e., the minimum cost of energy exchanged with the grid, whereas the negative sign of P_{EG} denotes the energy sold at price c . Two approaches are considered in the sequel. First approach is by using linear program formulation with combined whole smart building model that optimizes both building heating process and microgrid power exchange, and thus results in one large problem formulation. Second approach is by separating the individual thermal and microgrid optimization problems. The heating process is therefore observed as a separate and lower-hierarchical, consumption level problem.

For the unified problem of building and microgrid optimization, two systems are connected through building climate actuator powers, which are at the same time dynamic loads from the microgrid perspective, i.e., $P_L = P_{HVAC}$ (the sum for all rooms). Considered economic criterion of the microgrid operation with building zones actuator power over

the horizon of N is given by:

$$J^*(u) = \min_{P_{SC}, P_{BAT}, P_{FC}, P_L} \sum_{k=0}^N c_k T_s P_{EG}^k, \quad (22)$$

where the model matrices, state and input constraints are all joined in the same formulation. Economic criterion is included in the utility electricity price c_k in €/kWh for time period of one hour between k and $k + 1$ discrete time steps. Note that the criterion value J^* is expressed in € units and reflects the smart building contribution to energy saving and possibility of participation in electricity market bidding strategy. The negative sign of J^* means that power production exceeds power consumption. Complete power flow optimization problem is illustrated in Fig. 5.

C. Hierarchical Decomposition

With all of the listed elements in the optimization problem, the amount of time required for optimal solution outcome in each step grows drastically and possibly exceeds the sample time. One solution is to transfer all the required data via network, perform remote calculations on computer cluster acting as a cloud computing, and then transfer back control variables to the smart building. Another option is to work on the algorithm efficiency and reduction of time required for solving the problem. To this aim, we split one large problem of unified building and microgrid models and constraints into two separate, smaller problems. This separation is performed in the manners of hierarchical decomposition [48] where microgrid acts as a higher hierarchy level. Correlation between two hierarchy levels is drawn via dynamic load powers, i.e., climate actuator powers. This hierarchically decomposed power flow optimization problem is illustrated in Fig. 6, and mathematically formulated as:

$$J_\mu^*(u, x_0, P_L) = \min_{P_{SC}, P_{BAT}, P_{FC}} \sum_{k=0}^N c^k T_s P_{EG}^k, \quad (23a)$$

subject to : $\begin{cases} (11), (13), (15) \\ (16a), (17a), (18a) \\ (16b), (17b), (18b), (19) \end{cases}$

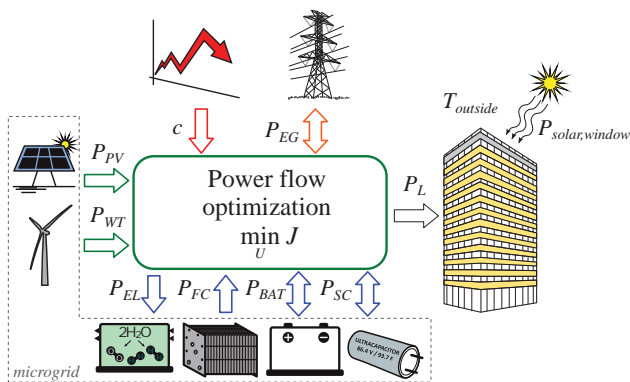

Fig. 5 Price-optimal power flow optimization for the case of unified building and microgrid control

$$J_L^* = \min_{\varepsilon, P_L^k} \varepsilon \quad (23b)$$

subject to : $\begin{cases} \varepsilon \geq J_\mu^*(P_L) \\ (??), (2), (3) \end{cases}$

Microgrid hierarchy level problem solution from (23a) aims at minimizing the power exchanged with the grid P_{EG} and reaching the minimum negative value. This is tried to be achieved while satisfying the constraints of storage units, power converters and requirements for dynamical load, and by taking into account power production units predictions and forecasted energy price. In other words, this means that the most favorable scenario is selling all the available power to the grid at the moment of maximum price along the prediction horizon. Lower, building hierarchy level solution from (23b) results in optimum heating/cooling power required to satisfy comfort demands while considering the forecasted ambient factors. The optimum solution from lower hierarchy level is aimed to be as close as possible to the optimum solution of the higher hierarchy level and if the two coincide, the smart building is operating in the most efficient way.

VI. RESULTS

A. Case Study

Simulation results are obtained for the case study of microgrid situated in the Laboratory for Renewable Energy Systems (LARES) at University of Zagreb Faculty of Electrical Engineering and Computing, Croatia, and for fully centralized and automated climate control for two floors of faculty building consisted of 38 offices. Microgrid components and corresponding constraints are given in Fig. 2. Smart building thermal model is chosen as RC model with comfort temperature held between 20°C and 24°C, and with 4.5 kW ventiloconvector in each room. Power production, consumption, prices and weather conditions are based on the realistic profiles. Renewables and storages from Fig. 8 are based on real components of LARES [42] and prices c are taken from European power exchange site [49] that accounts for more than a third of the total European power consumption. Weather forecast data is obtained from Croatian Meteorological and Hydrological Service (DHMZ). One day prediction horizon $T_s = 24$ h is used in simulations and two sequential autumn days of weather forecast are chosen.

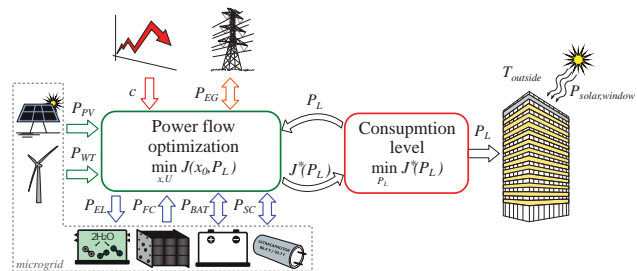

Fig. 6 Price-optimal power flow optimization for the case of hierarchically decomposed control.

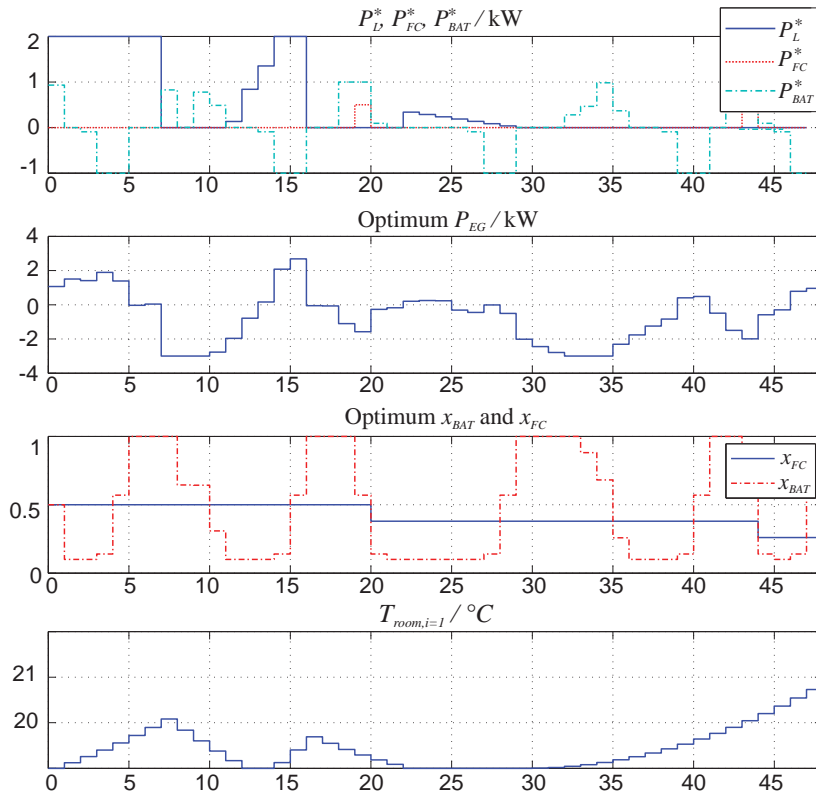

Fig. 7 Optimization results for unified problem case

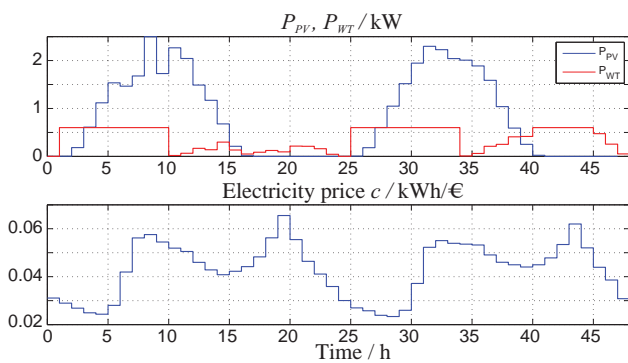

Fig. 8 Renewables power production and grid price

B. Simulation Results

Cost function minimization for both unified and hierarchical approaches is performed by using the Multi-parametric toolbox [50].

Fig. 7 shows power flow optimization results for the case of unified problem formulation. Fuel cells are left almost intact due to their low efficiency and batteries are much more used for storing power to be sold later. The figure shows that power P_{EG} is always sold at the highest prices. Performance of price-oriented optimization problem with chosen economical criterion may be observed in load power P_L and temperature profile of i^{th} room, $T_{room,i=1}$ in Fig. 7. Although the temperature at time instants of 1–7 h is above the constraint,

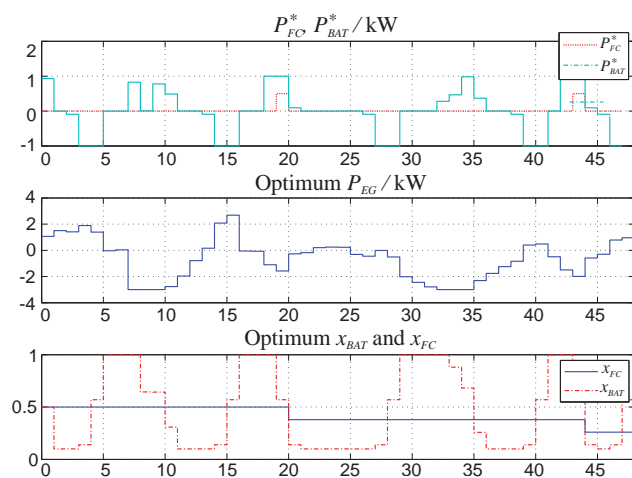

Fig. 9 Optimum power flows for hierarchically decomposed case

additional power is put into the building during the low price period such that the temperature is kept within constraints during the high energy price period and expensive power consumption is avoided.

For the case of hierarchical decomposition and described problem, responses are given in Fig. 9. Both unified and hierarchical approaches give matching results. Detailed analysis of the algorithm efficiency and speed increase is a matter of further research.

C. Further Possibilities

Lots of research so far was put into considering the problem of building climate optimal control and microgrid power flow balance as separate problems. Reason for this is, above all, large problem complexity followed by computational burden and very wide areas of expertise included into joining the two problems: civil, mechanical and electrical engineering, accompanied by weather forecasting and people behavior. However, from the perspective of high level of abstraction with power flow balances, large opportunities in energy efficiency and energy market strategies arise. Research trends are therefore expected to conjoin the problems and hierarchical approach is one of the contributions to the area.

Further opportunities arise in more time-efficient calculation of control law based on exploiting the problem unique formulation, starting position from previous time step problem solution and pinpointing critical regions where the positioning of solution within constraints can be performed very fast. In residential building area, zones are possible to be observed independently with distributed control approaches where comfort demands are more flexible and computations are additionally split with the aim of eligibility for cheap embedded controllers.

Once the algorithm efficiency is established, further extension of problem formulation onto lower levels of control such as heating pump efficiency or microgrid voltage control, all leading to larger contribution to energy efficiency.

VII. CONCLUSION

Model predictive control application proved to be valuable tool in high level power flow optimization application as sound energy costs saving approach. The paper presented an overview of methods and approaches used in buildings climate management and microgrid power distribution with MPC. All of the considered phenomena included in the optimization problem, together with short guidelines for the procedure is described and modeled. Both unified problem observation and hierarchy decomposition of the problem provide coinciding results for illustrative example of smart building with integrated microgrid and give opportunity for observing more complex problems independently.

ACKNOWLEDGMENT

This work has been fully supported by Croatian Science Foundation under the project No. 6731 (project 3CON – Control-based Hierarchical Consolidation of Large Consumers for Integration in Smart Grids, www.fer.unizg.hr/3con).

REFERENCES

- [1] Renewable Energy Policy Network for the 21st Century (REN21), Renewables 2015, Global Status Report, 2015.
- [2] M. Erol-Kantarci, H. T. Mouftah, "Energy-Efficient Information and Communication Infrastructures in the Smart Grid: A Survey on Interactions and Open Issues", *IEEE Communication Surveys & Tutorials*, vol. 17, no. 1, 2015.
- [3] A.-H. Mohsenian-Rad, A. Leon-Garcia, Optimal Residential Load Control With Price Prediction in Real-Time Electricity Pricing Environments, *IEEE Transactions on Smart Grid*, vol. 1, no. 2, 2010.
- [4] M. P. F. Hommelberg, C. J. Warmer, I. G. Kamphuis, J. K. Kok, G. J. Schaeffer, Distributed Control Concepts using Multi-Agent technology and Automatic Markets: an Indispensable Feature of Smart Power Grids, *Proceedings of the IEEE Power Engineering Society General Meeting*, pp. 7, 2007.
- [5] M. Sechilariu, B. Wang, F. Locment, "Building Integrated Photovoltaic System With Energy Storage and Smart Grid Communication", *IEEE Transactions on Industrial Electronics*, vol. 60, no. 4, pp. 1607–1618, 2013.
- [6] Y. Ma, F. Borrelli, B. Hancey, B. Coffey, S. Bengea, P. Haves, "Model Predictive Control for the Operation of Building Cooling Systems", *IEEE Transactions on Control Systems Technology*, vol.20, no.3, pp. 796–803, 2012.
- [7] A. Schirrer, O. König, S. Ghaemi, F. Kupzog, M. Kozek, "Hierarchical Application of Model-predictive Control for Efficient Integration of Active Buildings into Low Voltage Grids", *Proceedings of the 2013 Workshop on Modeling and Simulation of Cyber-Physical Energy Systems, MSCPES*, pp. 6, 2013.
- [8] X. Zhang, G. Schilbach, D. Sturzenegger, M. Morari, "Scenario-Based MPC for Energy-Efficient Building Climate Control under Weather and Occupancy Uncertainty", *Proceedings of European Control Conference, ECC*, pp. 1029–1034, 2013.
- [9] Y. Ma, J. Matuško, F. Borrelli: Stochastic Model Predictive Control for Building HVAC Systems: Complexity and Conservatism, *IEEE Transactions on Control Systems Technology*, vol. 23, no. 1, pp. 101–116, 2015.
- [10] J. Matuško, F. Borrelli, "Scenario-based approach to stochastic linear predictive control", *Proceedings of the IEEE Conference on Decision and Control, CDC*, pp. 5194–5199, 2012.
- [11] F. Oldewurtel, A. Parisio, C. N. Jones, M. Morari, D. Gyalistras, M. Gwerder, V. Stauch, B. Lehmann, K. Wirth, Energy Efficient Building Climate Control using Stochastic Model Predictive Control and Weather Predictions, *Proceedings of the American Control Conference*, pp. 5100–5105, 2010.
- [12] T. Žakula, P.R. Armstrong, L. Norford, "Modeling Environment for Model Predictive Control of Buildings", *Energy and Buildings*, vol. 85, pp. 549–559, 2014.
- [13] M. Vašak, A. Martinčević, "Optimal Control of a Family House Heating System", *Proceedings of the International Convention on Information and Communication Technology, Electronics and Microelectronics, MIPRO*, pp. 907–912, 2013.
- [14] A. Martinčević, A. Starčić, M. Vašak, "Parameter Estimation for Low-order Models of Complex Buildings", *Proceedings of the Innovative Smart Grid Technologies Europe, ISGT EUROPE*, pp. 6, 2014.
- [15] F. Oldewurtel, A. Parisio, C. N. Jones, D. Gyalistras, M. Gwerder, V. Stauch, B. Lehmann, M. Morari, "Use of Model Predictive Control and Weather Forecasts for Energy Efficient Building Climate Control", *Energy and Buildings*, vol. 45, pp. 15–27, 2012.
- [16] J. Drgoňa, M. Kvasnica, M. Klaučo, M. Fikar, "Explicit Stochastic MPC Approach to Building Temperature Control", *Proceedings of IEEE Conference on Decision and Control, CDC*, pp. 6440–6445, 2013.
- [17] D. Sturzenegger, D. Gyalistras, M. Gwerder, C. Sagerschnig, M. Morari, R. S. Smith, "Model Predictive Control of a Swiss Office Building", *Proceedings of the 11th REHVA World Congress Clima 2013*, 2013.
- [18] A. Bejan, A. D. Kraus, *Heat Transfer Handbook*, New Jersey: John Wiley & Sons, ISBN 0-471-39015-1, 2003.
- [19] C. Lu, M. Zheng, W. H. Leong, Verification and Analysis of a TRNSYS Model of a Demonstration House Equipped with a Solar Assisted Ground Coupled Heat Pump System, *Proceedings of the International Conference on Consumer Electronics, Communications and Networks, CECNet*, pp. 1887–1891, 2011.
- [20] W. J. Cole, E. T. Hale, T. F. Edgar, "Building Energy Model Reduction for Model Predictive Control Using OpenStudio", *American Control Conference, ACC*, pp. 449–454, 2013.
- [21] "User Manual IDA Indoor Climate and Energy", EQUA Simulation AB, 2013.
- [22] International Building Performance Simulation Association (IBPSA). (2015, Sep. 8). Building Energy Software Tools Directory. Available: <http://www.buildingenergysoftwaretools.com>
- [23] K. Deng, P. Barooah, P. G. Mehta, S. P. Meyn, "Building Thermal Model Reduction via Aggregation of States", *Proceedings of the American Control Conference, ACC*, pp. 5118–5123, 2010.
- [24] American Society of Heating Refrigerating and Air-Conditioning Engineers, "2009 ASHRAE Handbook, Fundamentals", 2009.
- [25] A. C. Antoulas, "An Overview of Model Reduction Methods and a New Result", *Proceedings of the IEEE Conference on Decision and Control, CDC*, pp. 5357–5361, 2009.

- [26] K. Glover, "All Optimal Hankel-norm Approximations of Linear Multivariable Systems and Their L(infinity)-error Bounds", *International Journal of Control*, vol. 39, no. 6, pp. 1115-1193, 1984.
- [27] M. G. Safonov, R. Y. Chiang, "Schur Method for Balanced-truncation Model Reduction", *IEEE Transactions on Automatic Control*, vol. 34, no. 7, pp. 729-733, 1989.
- [28] S. J. Julier and J. K. Uhlmann, "Unscented Filtering and Nonlinear Estimation", *Proceedings of the IEEE*, vol. 92, no. 3, pp. 401-422, 2004.
- [29] M. Maasoumy, B. Moridian, M. Razmara, M. Shahbakhti, A. Sangiovanni-Vincentelli, "Online simultaneous state estimation and parameter adaptation for building predictive control", *ASME Conference Proceedings*, vol. 2013, 2013.
- [30] J. Jang, "System Design and House Dynamic Signature Identification for Intelligent Energy Management in Residential Buildings", Ph.D. dissertation, Dept. Mech. Eng., Univ. California at Berkeley, Berkeley, CA, USA, 2008.
- [31] BSI, EN 15251:2007, Indoor Environmental Input Parameters for Design and Assessment of Energy Performance of Buildings Addressing Indoor Air Quality, Thermal Environment, Lighting and Acoustics.
- [32] S. Goyal, H. A. Ingley, P. Barooah, "Zone-Level Control Algorithms Based on Occupancy Information for Energy Efficient Buildings", *Proceedings of the American Control Conference, ACC*, pp. 3063-3068, 2012.
- [33] M. Gulin, M. Vašak, M. Baotić, "Analysis of Microgrid Power Flow Optimization with Consideration of Residual Storages State", *Proceedings of the 2015 European Control Conference, ECC*, pp. 3131-3136, 2015.
- [34] W. S. Parker, "Predicting Weather and Climate: Uncertainty, Ensembles and Probability", *Studies in History and Philosophy of Modern Physics* vol. 41, no. 3, pp. 263-272, 2010.
- [35] R. H. Lasseter, Smart Distribution: Coupled Microgrids, *Proceedings of the IEEE*, vol. 99, no. 6, pp. 1074-1082, 2011.
- [36] A. Parisio, E. Rikos, L. Glielmo, "A Model Predictive Control Approach to Microgrid Operation Optimization", *IEEE Transactions on Control Systems Technology*, vol. 22, no. 5, pp. 1813-1827, 2014.
- [37] P. O. Kriett, M. Salani, "Optimal control of a residential microgrid", *Energy*, vol. 42, no. 1, pp. 321-330, 2012.
- [38] G. Comodi, A. Giantomassi, M. Severini, S. Squartini, F. Ferracuti, A. Fonti, D. Nardi Cesarini, M. Morodo, F. Polonara: Multi-apartment Residential Microgrid with Electrical and Thermal Storage Devices: Experimental Analysis and Simulation of Energy Management Strategies, *Applied Energy*, vol. 137, pp. 854-866, 2015.
- [39] F. Blaabjerg, D. M. Ionel, "Renewable Energy Devices and Systems State-of-the-Art Technology, Research and Development, Challenges and Future Trends", *Electric Power Components and Systems*, vol. 43, no. 12, pp. 1319-1328, 2015.
- [40] M. Gulin, M. Vašak, T. Pavlović, Dynamical Behaviour Analysis of a DC Microgrid in Distributed and Centralized Voltage Control Configurations, *Proceedings of the 23rd International Symposium on Industrial Electronics, ISIE*, pp. 2365-2370, 2014.
- [41] M. Gulin, M. Vašak, N. Perić, "Dynamical optimal positioning of a photovoltaic panel in all weather conditions", *Applied Energy*, vol. 108, pp. 429-438, 2013.
- [42] M. Gulin, M. Vašak, T. Pavlović, "Model Identification of a Photovoltaic System for a DC Microgrid Simulation", *Proceedings of the 16th International Power Electronics and Motion Control Conference and Exposition, PEMC*, pp. 501-506, 2014.
- [43] M. Gulin, J. Matuško, M. Vašak, "Stochastic Model Predictive Control for Optimal Economic Operation of a Residential DC Microgrid", *Proceedings of the 2015 IEEE International Conference on Industrial Technology, ICIT*, pp. 505-510, 2015.
- [44] M. Gulin, M. Vašak, G. Banjac, T. Tomiša, "Load Forecast of a University Building for Application in Microgrid Power Flow Optimization", *Proceedings of the IEEE International Energy Conference, EnergyCon*, pp. 1284-1288, 2014.
- [45] L. Y. Pao, K. E. Johnson, "Control of Wind Turbines: Approaches, Challenges, and Recent Developments", *IEEE Control Systems Magazine*, vol. 31, no. 2, pp. 44-62, 2011.
- [46] S. Widergren, C. Marinovici, T. Berliner, A. Graves, "Real-time Pricing Demand Response in Operations", *Power and Energy Society General Meeting*, pp. 5, 2012.
- [47] C. Eksin, H. Delic, A. Ribeiro, "Real-Time Pricing with Uncertain and Heterogeneous Consumer Preferences", *Proceedings of the American Control Conference, ACC*, pp. 5692-5699, 2015.
- [48] R. Scattolini, "Architectures for distributed and hierarchical Model Predictive Control: A review", *Journal of Process Control*, vol. 19, no. 5, pp. 723-731, 2009.
- [49] EPEX SPOT. (2015, Sep. 8). European Power Exchange Electricity Index. Available: <http://www.epexspot.com>
- [50] M. Herceg, M. Kvasnica, C.N. Jones, M. Morari, "Multi-Parametric Toolbox 3.0", *Proceedings of the European Control Conference, ECC*, pp. 502-510, 2013.