

Review, Analysis and Simulation of Advanced Technology Solutions of Selected Components in Power Electronics Systems (PES) of More Electric Aircraft

Lucjan Setlak, Emil Ruda

Abstract—The subject of this paper is to review, comparative analysis and simulation of selected components of power electronic systems (PES), consistent with the concept of a more electric aircraft (MEA). Comparative analysis and simulation in software environment MATLAB / Simulink were carried out on the base of a group of representatives of civil aircraft (B-787, A-380) and military (F-22 Raptor, F-35) in the context of multi-pulse converters used in them (6- and 12-pulse, and 18- and 24-pulse), which are key components of high-tech electronics on-board power systems of autonomous power systems (ASE) of modern aircraft (airplanes of the future).

Keywords—Converters, electrical machinery, more electric aircraft, MEA, power electronics systems, PES.

I. INTRODUCTION

IN modern aircraft of the key airline companies, both civil aviation (Boeing, Airbus) and military aviation (Lockheed Martin), can be seen continuous development in the field of electrical machines [1], [2], which occurs due to the dynamic technological progress of analogous fields of science, first of all the advanced power electronics in the field of power electronics systems PES (*Power Electronics Systems*) [3], equipment and materials, and what goes with it - the advanced integrated avionics.

Conventional power supply systems on board modern aircraft have been replaced by advanced power electronics systems (PES), which are more resistant to failures of electrical machines and electro-hydrostatic actuators EHA (*Electrohydrostatic Actuators*) and electromechanical EMA (*Electromechanical Actuators*) [4]. The paper presents a comparison and the resulting differences in conventional aircraft and compatible with the concept a more electric aircraft (MEA), as shown in Figs. 1 and 2 [5].

These changes are directly linked with the development of the recent trends of partially electric aircraft (MEA) and fully electric aircraft AEA (*All Electric Aircraft*), which formed part of a wider concept, ie. the so-called MOET project (*More Open Electrical Technology*). The idea of formed concept (MEA) is to replace conventional key aviation equipment and

systems powered by mechanical, pneumatic and hydraulic energy by devices, systems and electricity systems powered in part MEA (*More Electric Aircraft*) or completely AEA (*All Electric Aircraft*) [6]. The paper analyzed the most important, and what goes with it important in the context of flight safety advantages of this arrangement created by the dynamic development of power electronics systems (PES), and their key components such as transducers, transmitters cycles, transformers, blocks amps transformers, etc., generally referred to in the literature as PE systems (*Power Electronics*). Given that the biggest trend in terms of function of more electric aircraft (MEA) is assigned to civil aviation, main (fully justified) role in this paper will be assigned to civil aviation aircraft of the key airline companies (Boeing, Airbus).

II. SELECTED COMPONENTS OF POWER ELECTRONICS SYSTEMS (PES)

A. Multipulse Rectifiers Review

The key and at the same time the most important components of the power electronics systems PES are widely used both in military aviation and civil aviation are transducers. Power converters powered by on-board electricity networks are called chargers for processing AC voltage to DC voltage and frequency converters (inverters) when processing a DC voltage to AC voltage. Figs. 3 and 4 illustrate the basic components of the Electric Power System (EPS) of a transport aircraft, including key elements of PES (Power Electronics System) in the context of the distribution and transmission of electricity PDS (Power Distribution System) [7].

When making a literature review of the basic elements of PES, there are two types of sensors: CSC (*Current Source Converters*) and VSC (*Voltage Source Converters*), the CSC transducers are typical transducers, requiring the use of a filter of high power, necessary to eliminate AC harmonics, in addition to the DC filter.

Generally in EPS (*Electric Power Systems*) for aeronautical applications are used AC receivers with a constant (stabilized) frequency of 400 Hz and DC receivers. However, in most modern aircrafts, both civilian aircrafts (A-380, B-787), as well as military (F-22 Raptor, F-35) are used advanced EPS with a variable frequency in the range of 360-800 Hz. So far applied voltage sources, which are dynamos and alternators

L. Setlak is with the Air Force Academy, Deblin, Poland (phone: +48-601-463-949, e-mail: lucsetwsosp.edu.pl@wp.pl).

E. Ruda is with the 33. Air Transport Base, Powidz, Poland (phone: +48-661-571-938, e-mail: emiliruda@gmail.com).

and associated with them power supply systems (AC and DC) are the uneconomic and technically difficult to implement solution. The current technological development in the field of electrical machines, in particular the derivatives of areas such as electronics and power electronics, allows to reduce (decrease) the number of electric power systems (EPS) to the only one power system - EPS AC, leaving emergency power sources, which are an accumulator battery (batteries) or auxiliary power unit (APU) [8]. Application of advanced components of power electronic systems (PES), which are modern electronic systems PE (Power Electronics) fully, complies with the requirements for the implementation of converters. The purpose of the converters is to match one type of power system AC for all kinds of receivers on board

modern aircraft, regardless of the value and type of direct and alternating current (AC and DC). A prerequisite for this is the realization of many studies to obtain in the electric power system EPS relevant parameters, namely the value of PF (Power Factor) and the aspect ratio signals THD (Total Harmonic Distortion), which play important functions. Power factor (PF) is part of the economic effects; the aspect ratio of the signal (THD) is part of the electromagnetic compatibility [9], [10]. Fig. 5 shows the options to use transmitters in the context of the implementation of the concept MOET (*More Open Electrical Technologies*) in the field of aircraft partially and fully electric MEA (*More Electric Aircraft*) and AEA (*All Electric Aircraft*) [10].

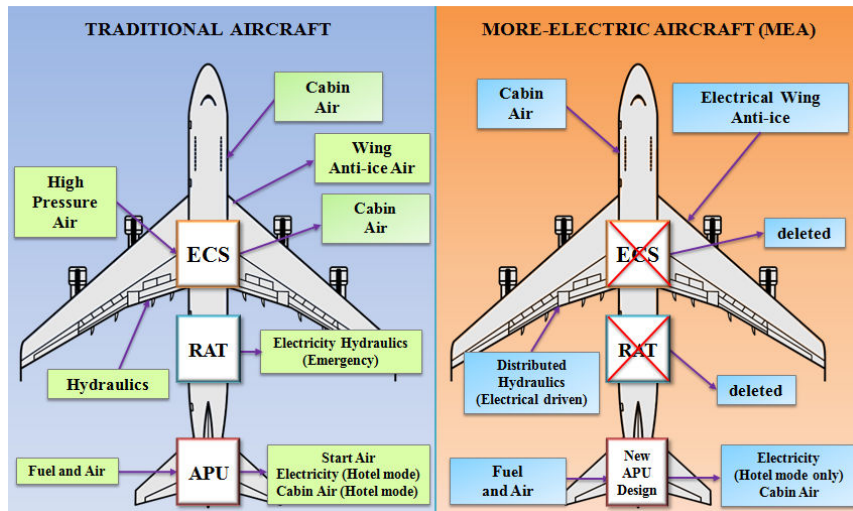

Fig. 1 Comparison of a Conventional Aircraft and More Electric Aircraft

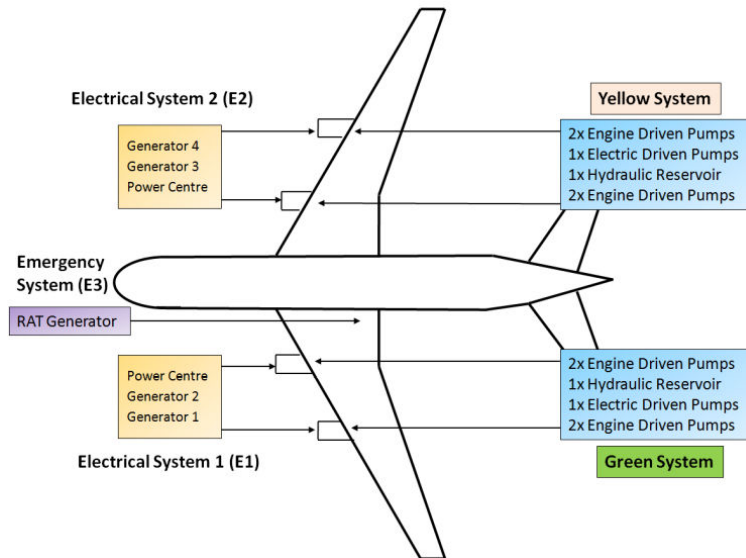

Fig. 2 A-380 Flight Control Actuation

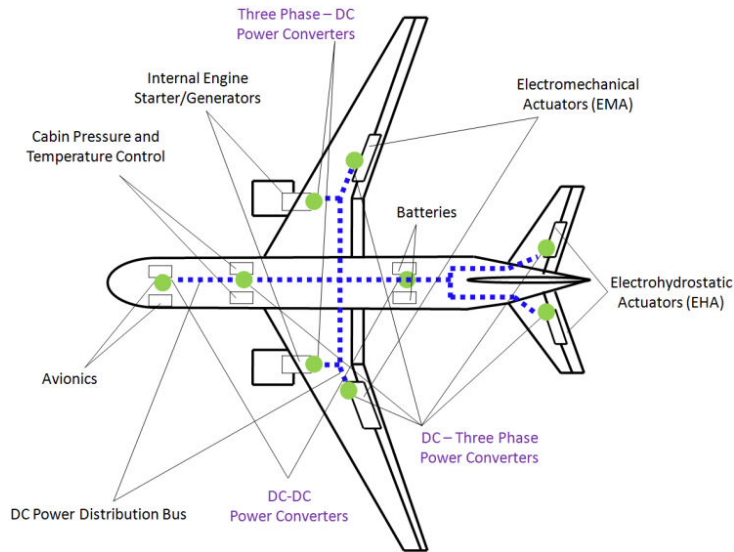

Fig. 3 Power Distribution System (PDS) of a transport aircraft

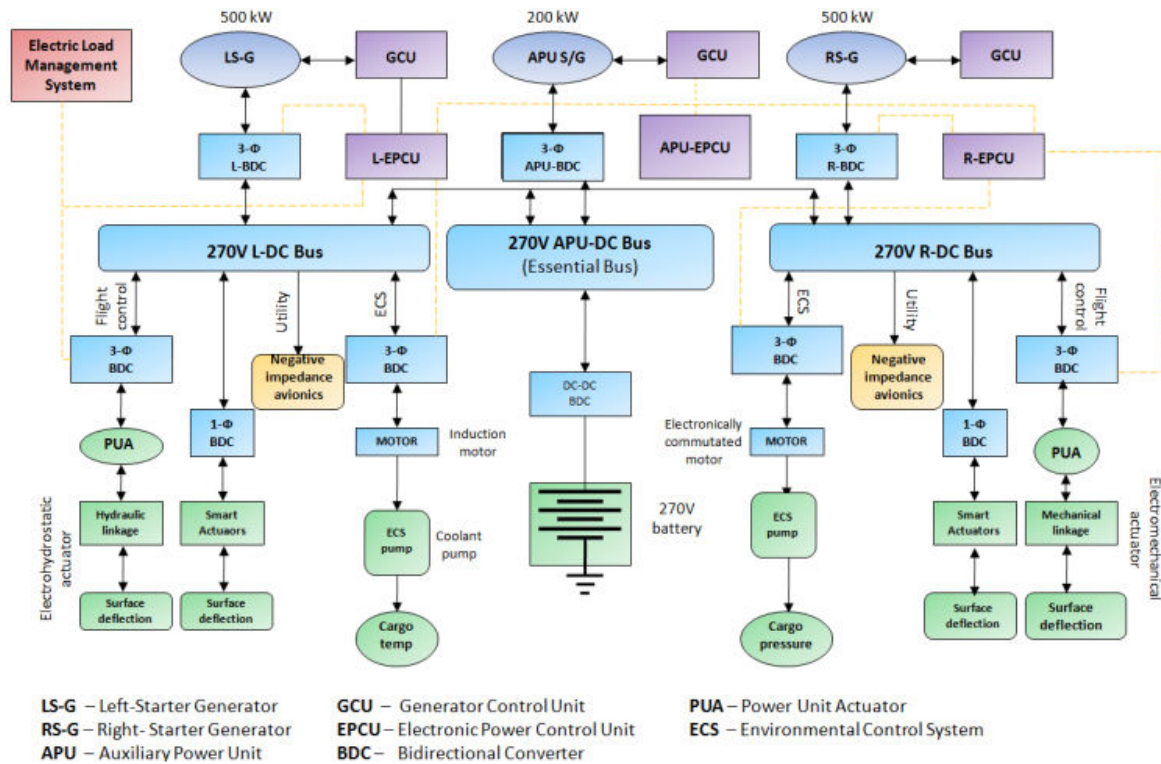

Fig. 4 Power Distribution System (PDS) Architecture

AC Electric Power Systems (EPS) with a variable frequency between 400 and 900 Hz are used both in the military (F-16, F-22 Raptor, F-35), as well as civil aircraft (A-380, B-787). In addition, these systems are complemented with DC Electric Power Systems (EPS) with voltages of different values, adapted to a variety of receivers used on board modern aircraft [11], [12]. In the aerospace industry, including in particular in aerospace, PEC (*Power Electronics*

Converters), whose topology is shown in Fig. 5, play a significant role in the use of the DC voltage. Over the last decade the use of a supply voltage of AC spurred the development of more electric technology - MET, which resulted in rapid growth in the use of power electronic converters for inspection and control of advanced systems used on board the most modern aircraft, both civilian and military.

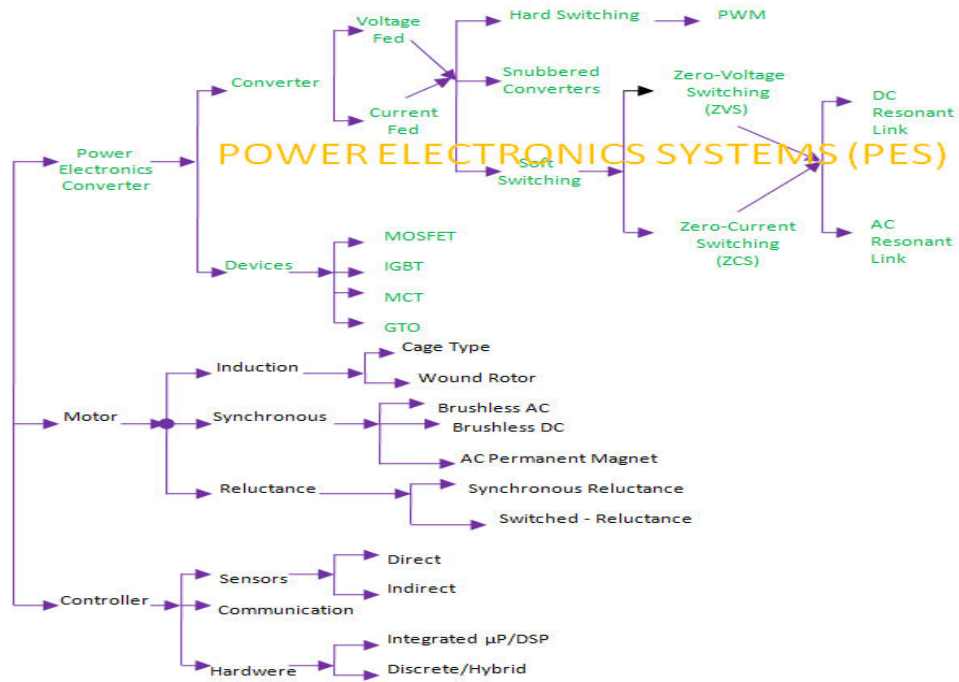

Fig. 5 Options for 'More Electric' Technology (MET)

B. Analysis and Simulation of Basic Multipulse Converters

Basic (regular) multipulse converters were characterized and compared using both civilian aircraft (A-320, B-737), as well as military aircraft (MiG-29, F-16), which are not compatible with the concept of the more electric aircraft MEA. Comparative characteristic and simulation using software environment MATLAB / Simulink of primary multipulse converters were carried out on the example of rectifier circuits of military aircraft F-16 - (6-pulse) and rectifier systems used on civil aircraft A-320 and B-737.

1. An AC-DC Rectifier (6-Pulse)

On the multi-purpose F-16 aircraft to power the entire electrical system and load current are used two sets of rectifier AC-DC voltage of 28V, whose task is to process 3-phase AC voltage of 115V / 200V DC voltage, containing the between 26 ÷ 29,5V. These are called. Static converters, power to the emergency bus of alternating current (No. 1, 2). The flowchart AC / DC converter consists of the following elements shown in Fig. 6: 400 Hz filter; transformer (2 windings) Y, delta; full wave rectifier, and lowpass filter the type of II.

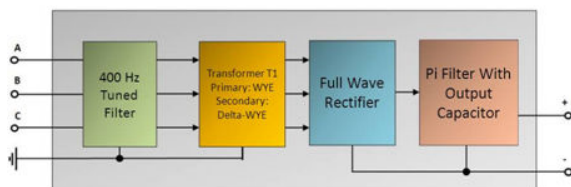

Fig. 6 Block diagram of an AC-DC military aircraft F-16

2. An AC-DC Rectifier (12-Pulse)

Multipulse rectifier AC-DC converter is widely used for civil aircraft of various types; in particular, it is used on aircrafts consistent with the concept of MEA. These systems are used for supplying DC power to all the necessary electrical DC receivers, on board the aircraft. They are supplied (in analogy to 6-pulse systems of military aircraft) with three-phase alternating current, which is applied to the primary winding of the transformer. In this device processing area of the AC voltage, then this voltage via 2 secondary windings is served to the rectifier. Such a rectifier is composed of two rectifiers (6 diodes each), in which is alternating current converted to direct current (Fig. 7).

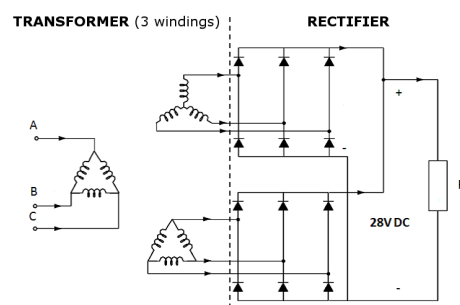

Fig. 7 Diagram of AC-DC rectifier on civil aircraft

Example characteristics of the selected components of power electronic systems (PES) on the example presented earlier transmitters 6- and 12-pulse for civil and military aircraft were illustrated in Figs. 8-14. The idea of sample layouts rectifier military aircraft (Fig. 11), and aircraft of civil

aviation (Fig. 12) lies in the fact that AC reduced after passing through the transformer is fed to the rectifier circuits (6- and 12-pulse). Rectifying property, these systems achieve through the use of semiconductor diodes which straightening current use properties of the unidirectional conduction of electric current. The rectifier circuit of a military aircraft uses 3-phase half-wave rectifier (6-pulse), which has a small ripple. On the other hand, 12-pulse rectifier, which were used primarily for civil aircraft compared to the systems 6-pulse rectifier they are more accurate and have a much lower level of ripple in

comparison with the half-wave rectifier. The last element is the so-called filtering circuits, with the key purpose to reduce the amplitude of the ripple of the output current. It should also be noted that the transmitter of military aircraft uses low-pass filter type II, which significantly contributes to improving the quality of the resulting current. Figs. 8 and 9 are block diagrams of rectifiers (6- and 12-pulse) in the Simulink and Figs. 13 and 14 were imaged characteristic voltage and current of the output from the AC-DC transducers of these systems.

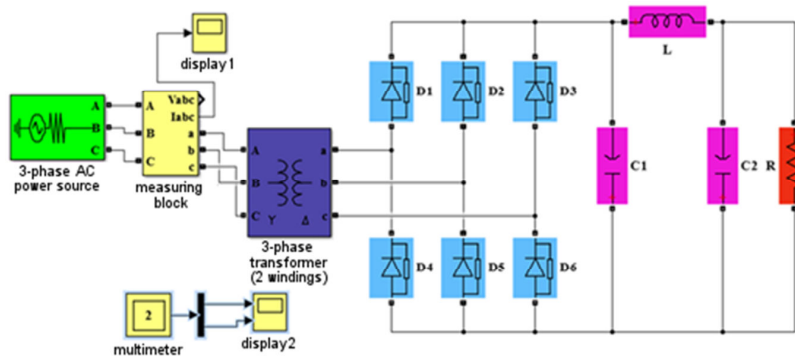

Fig. 8 Block diagram of a 6-pulse AC-DC converter military aircraft in the program Simulink

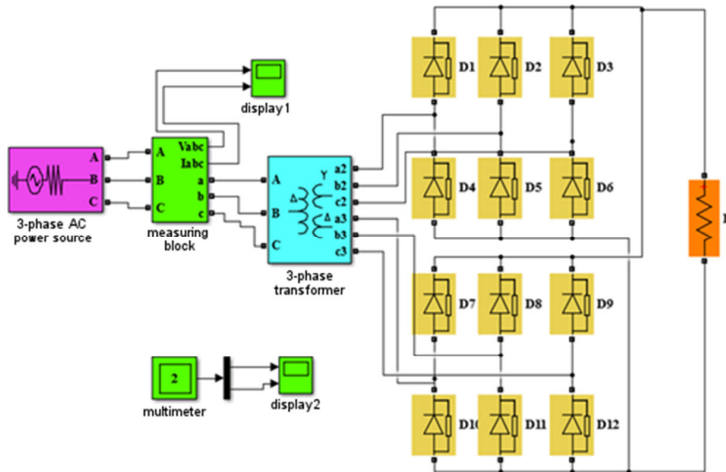

Fig. 9 Block diagram of 12-pulse AC-DC converter civil aircraft in the program Simulink

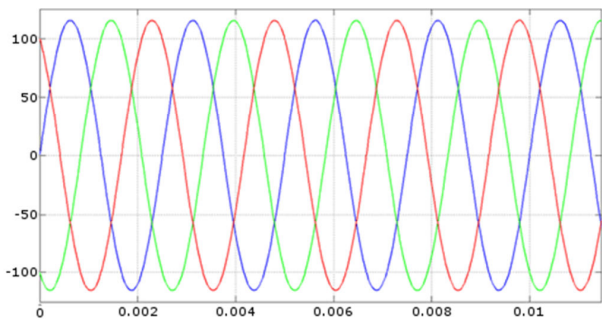

Fig. 10 Characteristics voltage three-phase current AC power of AC-DC converters

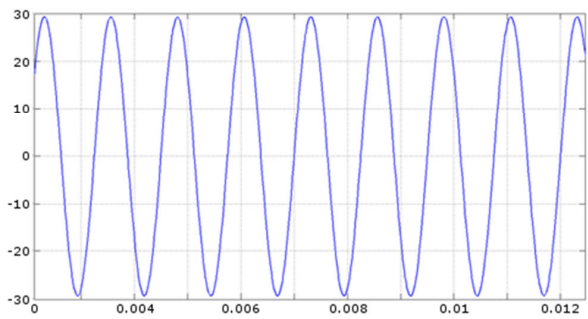

Fig. 11 Characteristics of voltage and current after leaving the 6-pulse AC-DC converter military aircraft

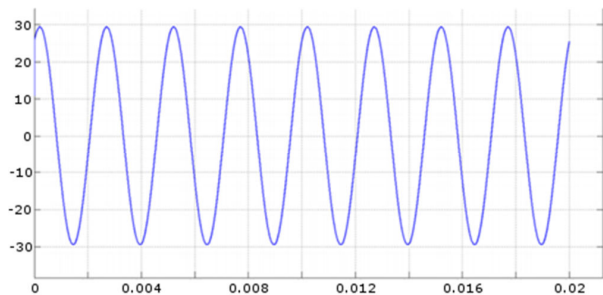

Fig. 12 Characteristics of the output voltage of the transformer 12-pulse AC-DC converter of civil aircraft

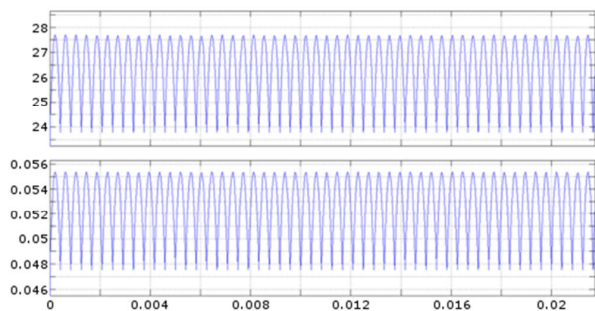

Fig. 13 Characteristics of voltage and current after leaving the 6-pulse AC-DC converter of military aircraft

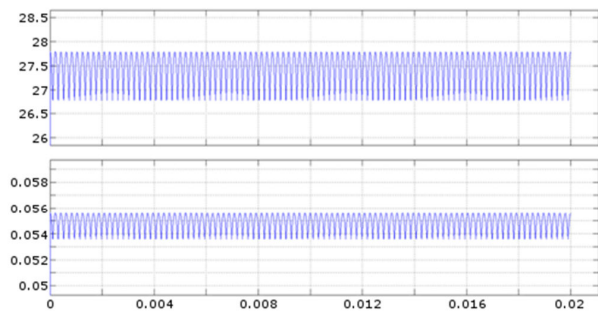

Fig. 14 Characteristics of voltage and current after leaving the 12-pulse AC-DC converter of civil aircraft

III. MORE OPEN ELECTRICAL TECHNOLOGIES FOR ADVANCED AIRCRAFT

The dynamic development in the field of electrical machines and its derivatives areas, which are electronics and power electronics started the trend of more open technologies for electrical power both in civil aviation (A-380, B-787), as well as military (F-22 Raptor, the F-35). These changes are closely linked to the implementation of a more electric aircraft concept MEA, which was established as part of a broader concept, namely the so-called. Project a more open technology in the field of electricity MOET (More Open Electrical Technology) or in the near future, the concept of fully electric aircraft AEA. The idea of the resulting trend of more electric aircraft MEA (electrified) is to replace air pneumatic and hydraulic equipment electrical equipment. As a result, instead of currently existing aboard modern aircraft 3 different

generation systems and power allocation are used one - the power system.

Fig. 15 presents the concept of a more electric aircraft MEA on the example of a military aircraft aviation company Lockheed Martin F-35 Joint Strike Fighter (JSF). Fig. 16 shows schematic conceptual subsystems of advanced military aircraft F-35 that meets the concept of a more electric MEA and multi-role aircraft F-16 [13].

In accordance with the concept of critical subsystems of F-35, such as hydraulic subsystem of flight control actuators EHA, subsystem gearbox driving a fuel pump and the air-driven controlled subsystem ECS (*Environmental Control System*) are powered electrically by an electric drive motor. The generator-starter AC voltage AS/G (Alternating Starter/Generator) provides electricity to the subsystem based on power and distribution of electricity PMAD (*Power Management and Distribution*) resistant to damage. The primary purpose of this subsystem is the supply of electricity to an electric actuator EA (*Electric Actuation*), launch (start) the engine, ECS, fuel pump and the installation of anti-icing. In addition, the PMAD system provides redundancy (release) and start the engine by incessant power with integrated auxiliary power unit APU and batteries. Important elements for driving the electric motor in accordance with the concept of MEA for a more electric technologies MET are: IM (*Induction Motor*) BLDCM (*Brush-Less Direct-Current Motor*) and SRM (*Switched Reluctance Motor*). It should be emphasized that for each of these actuators in accordance with the technology MET, depending on the application, an electric actuator EA and the electronic control unit (controller) has to be adjusted security and reliability of a hydraulic drive. This may be conditioned by the need for redundancy (dismissal) of the drive motor to provide flight and landing. Therefore, incorporating redundancy in an independent motor winding because of magnetic isolation, and power supply of switching circuits through magnetic isolation makes the switched reluctance linear motors (SRM) an attractive choice for fault tolerant electric actuators EA. This ability to failover the engine, SRM is one of the key factors in its selection by the military, meets concept more electric aircraft MEA for a more electric technology MET or more advanced technology MOET, initiated by the Air Airbus company (A-380, A-350 XWB).

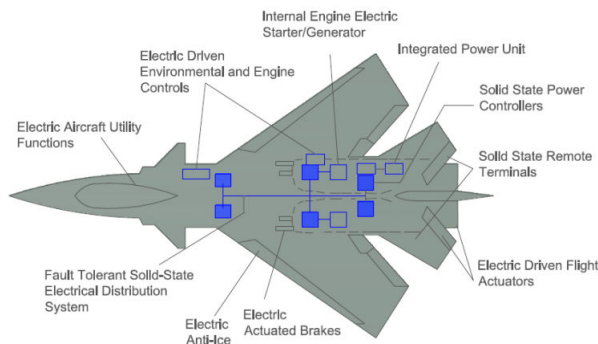

Fig. 15 Concept of More Electric Aircraft (MEA)

Affordable, High - Performance Baseline for F-35

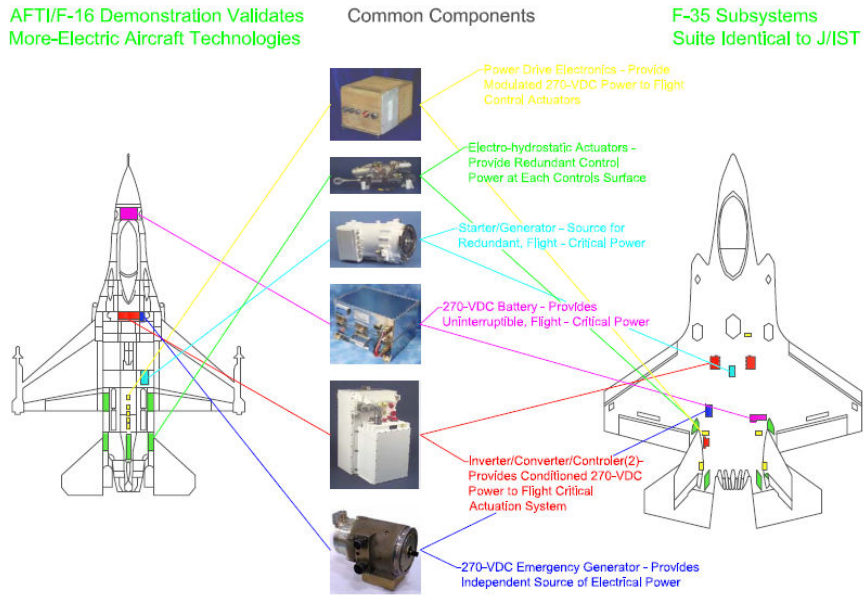

Fig. 16 Comparative characteristics of subsystems of the F-16 and F-35 are compatible with the concept of MEA

IV. COMPARATIVE ANALYSIS AND SIMULATION OF MULTI-PULSE TRANSDUCERS

A. Basic Multi-Pulse Converters (Example Model and Simulation)

Simulation of basic multipulse transmitters was presented basing on multi-task military aircraft F-16. Key components of electronics power supply systems (PES), which are multi-pulse converters, part of the electric power system (EPS) DC and AC voltage [14]. In order to exemplary technological solution selected PES component, consistent with the concept of a more electric aircraft MEA, created a model of the AC-DC rectifier, the simulation on this model, made its analysis and practical conclusions drawn.

1. The Model of the AC-DC Rectifier

The model of the AC-DC rectifier (Fig. 17) made from blocks of "Three-Phase Transformer (Two Windings)" "Fullwave Rectifier" and "Pi Filter". Block Parameters "Three-Phase Transformer (Two Windings)" are shown in Table I.

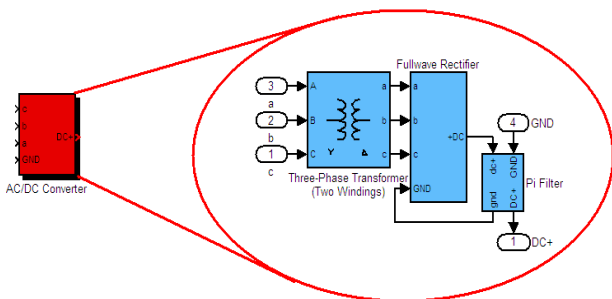

Fig. 17 Model of the AC-DC rectifier

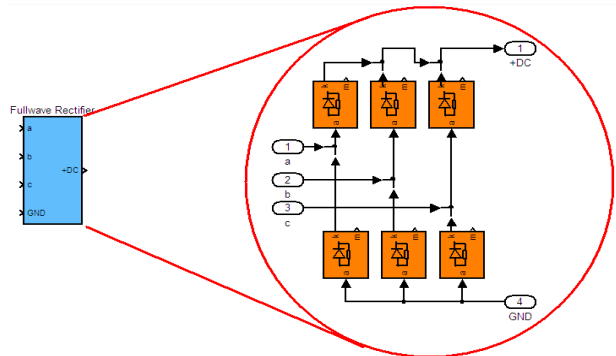

Fig. 18 Model of full-wave rectifier circuit

TABLE I
PARAMETERS OF TRANSFORMER BLOCK

Parameter	Value
Nominal power	3600 VA
Nominal frequency	400 Hz
Primary winding:	
Type of winding	WYE
Vrms ph-ph	$\frac{200}{\sqrt{2}} V$
Secondary winding:	
Type of winding	Δ -WYE
Vrms ph-ph	$\frac{28\pi}{3\sqrt{2}} V$

2. Model of Full-Wave Rectifier

Model of full-wave rectifier (Fig. 18) composed of six blocks of a rectifying diode the parameters outlined in Table II.

TABLE II
BLOCK PARAMETERS RECTIFYING DIODE

Parameter	Value
Internal resistance	0.01 Ω
Internal inductance	0 H
Reverse voltage	0.8 V
Initial current	0 A

3. Filter Model II

Filter model II (Fig. 19) consists of a block capacitor connected in parallel to the DC circuit and a block of the inductor L in series. The parameters are shown in Table III.

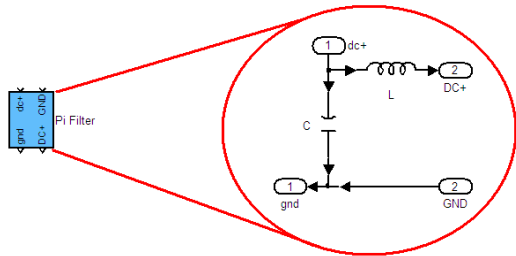

Fig. 19 Filter model II

TABLE III
BLOCK PARAMETERS "PI FILTER"

Parameter	Value
L element inductance	281.3e-3
C element capacitance	1.125e-6

4. Simulations of the Created Model (AC-DC Transmitter Operation)

In order to verify the correct operation of the AC-DC transmitter model simulation was made at nominal power and

5. Operation of an AC-DC Converter (in the Whole EPS)

a load converter, equal to 500 Ω, at t = 0.05 s. The results of the simulation are shown in Fig. 20.

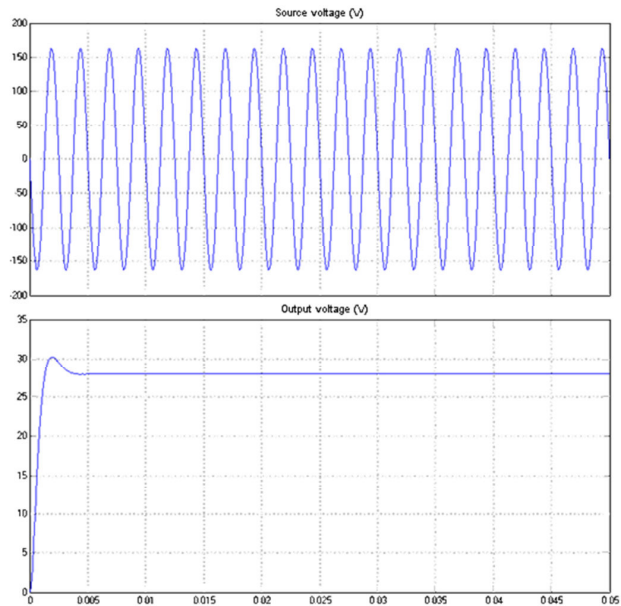

Fig. 20 Charts operation AC-DC converter

The analysis of the graphs above can be concluded that the output voltage of AC-DC converter is maintained at 28V, which means that they have been met assumptions.

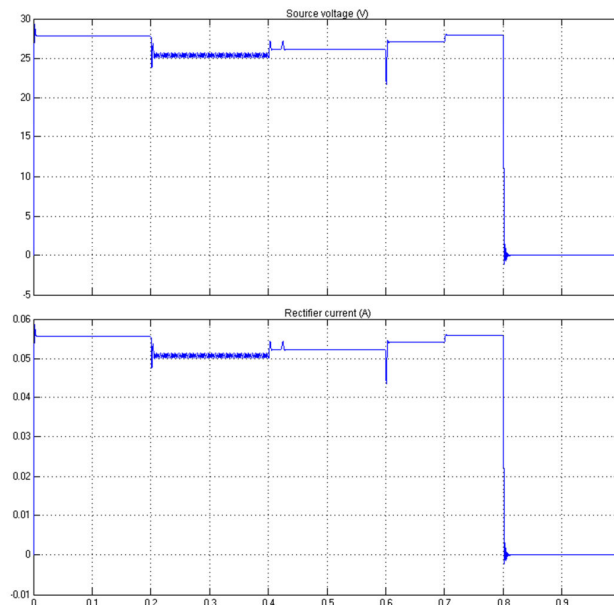

Fig. 21 Voltage and electric current of an AC-DC converter No. 1

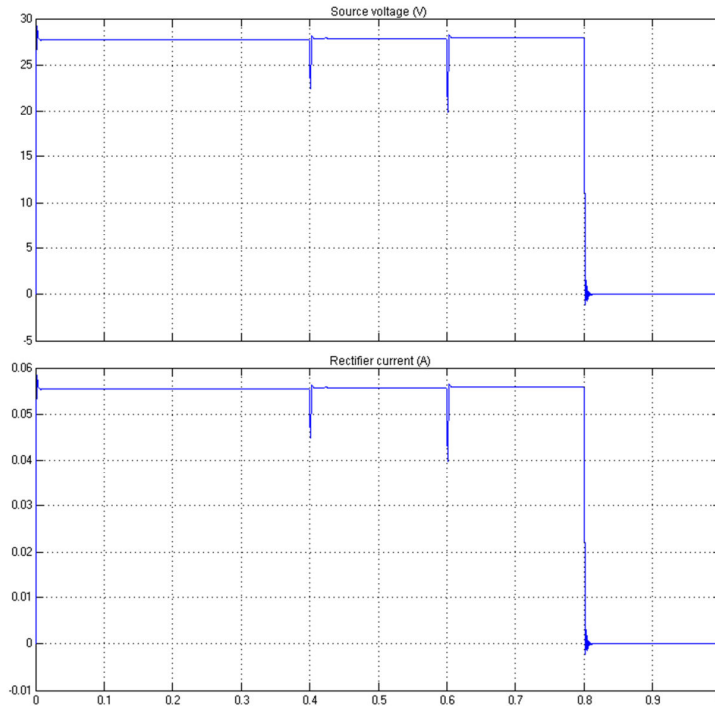

Fig. 22 Voltage and amperage of AC-DC converter No. 2

Fig. 21 illustrates the voltage and DC current outgoing the AC-DC converter 1. As stated, at $t = 0.2s$ converter output voltage decreased to a value of approx. 25V. On the other hand, in a time interval of $0.4 \div 0.6s$ maintained value of approx. 26V, and 27V to the time $t = 0.7s$. Then, in a time interval of $0.7 \div 0.8s$ output voltage returned to a value of 28V and then dropped to zero. In contrast, Fig. 19 shows the voltage waveform and a current output an AC-DC No. 2 in time. It has been found that from the beginning of the simulation, up to 0,8s voltage maintains a constant value of approx. 28V, then decreased to zero. Only at times $t = 0.4 s$ and $t = 0,6s$ temporarily simulation was followed by a voltage drop to a value of approx. 20V. The aforementioned phenomena for an AC-DC No. 1 are associated with switching to operation in the time interval $t = 0,3 \div 0,7s$ electro-mechanical actuator. In contrast, sudden drops in voltage AC-DC converter No. 2 merely the result of which activates a relay operation to work further sources of electricity after successive failures.

B. Advanced Multi-Pulse Converters

In order to check the operation of multipulse transmitters simulation was made at nominal power and load in time $t = 0,0025s$. The simulation results are shown in Figs. 23-35 and Tables IV-VII.

1. 6-Pulse Rectifier

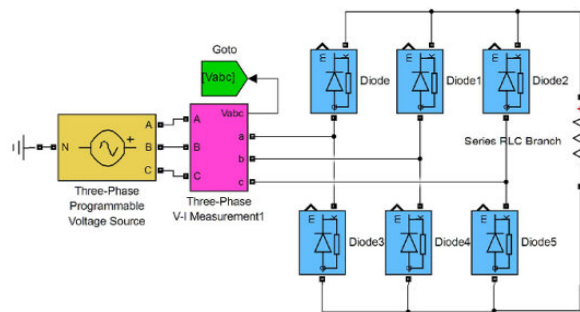

Fig. 23 Block diagram of 6-pulse rectifier SIMULINK model

TABLE IV
PARAMETERS OF 6-PULSE RECTIFIER

Parameters of AC sources	Source 1
Vrms ph-ph	115V
Phase shift	0°
Frequency	400 Hz

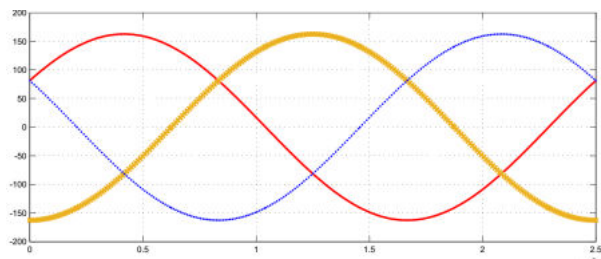

Fig. 24 Source voltage characteristics

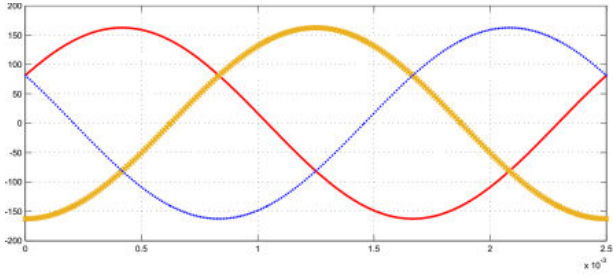

Fig. 25 Output voltage characteristics

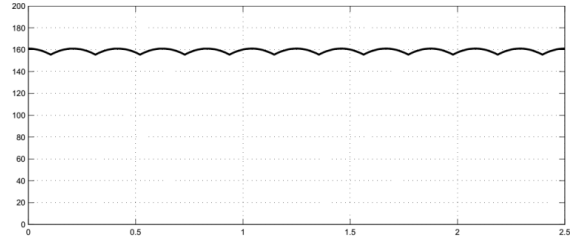

Fig. 28 Output voltage characteristics

2. 12-Pulse Rectifier

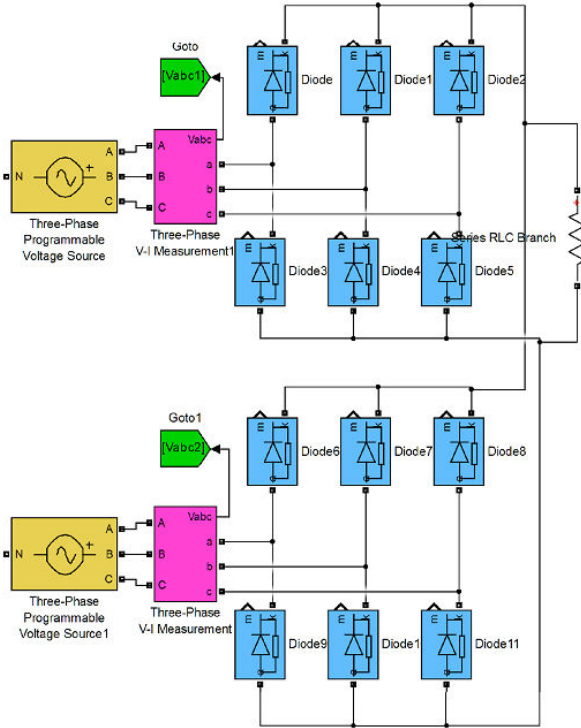

Fig. 26 Block diagram of 12-pulse rectifier SIMULINK model

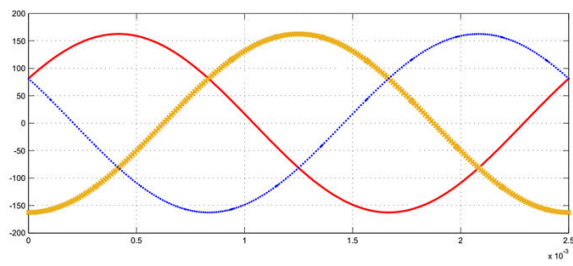

Fig. 27 Source No. 1 and No. 2 voltage characteristics

TABLE V

PARAMETERS OF 12-PULSE RECTIFIER

Parameters of AC sources	Source 1	Source 2
Vrms ph-ph	115V	115V
Phase shift	0°	30°
Frequency	400 Hz	400 Hz

3. 18-Pulse Rectifier

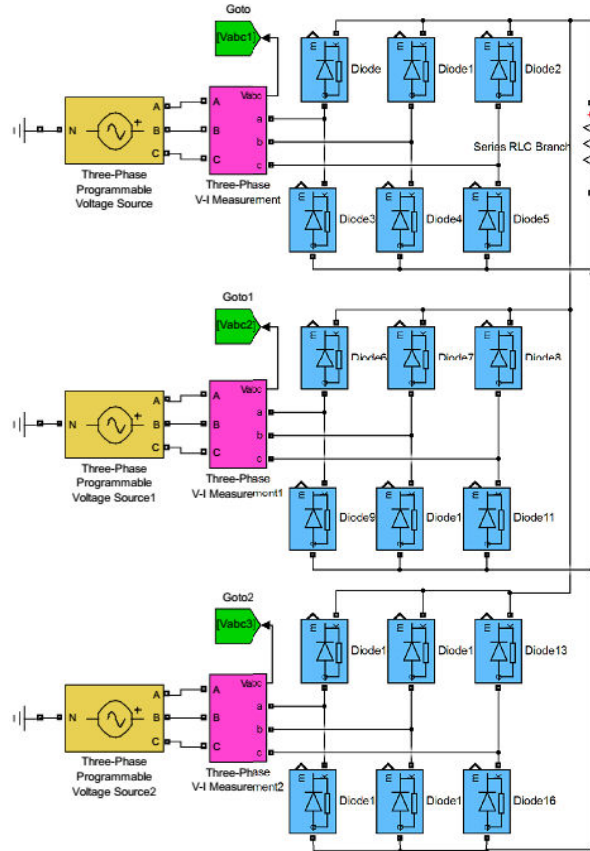

Fig. 29 Block diagram of 18-pulse rectifier SIMULINK model

TABLE VI

PARAMETERS OF 18-PULSE RECTIFIER

Parameters of AC sources	Source 1	Source 2	Source 3
Vrms ph-ph	115V	115V	115V
Phase shift	0°	20°	40°
Frequency	400 Hz	400 Hz	400 Hz

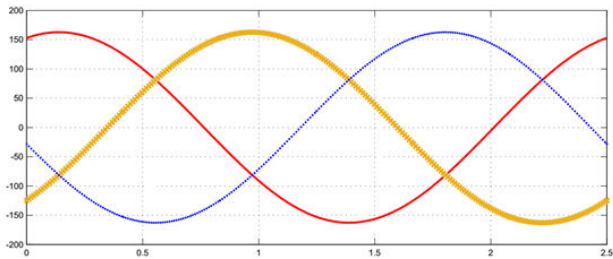
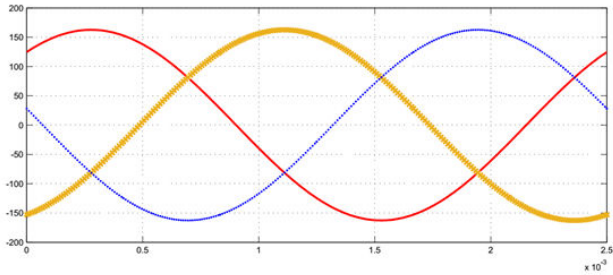
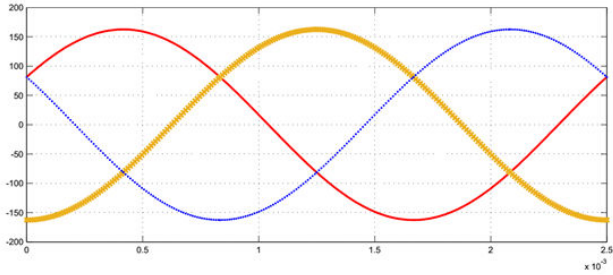

Fig. 30 Source No. 1÷No.3 voltage characteristics

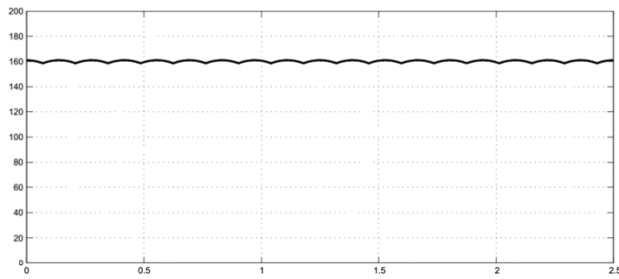

Fig. 31 Output voltage characteristics

4. 24-Pulse Rectifier

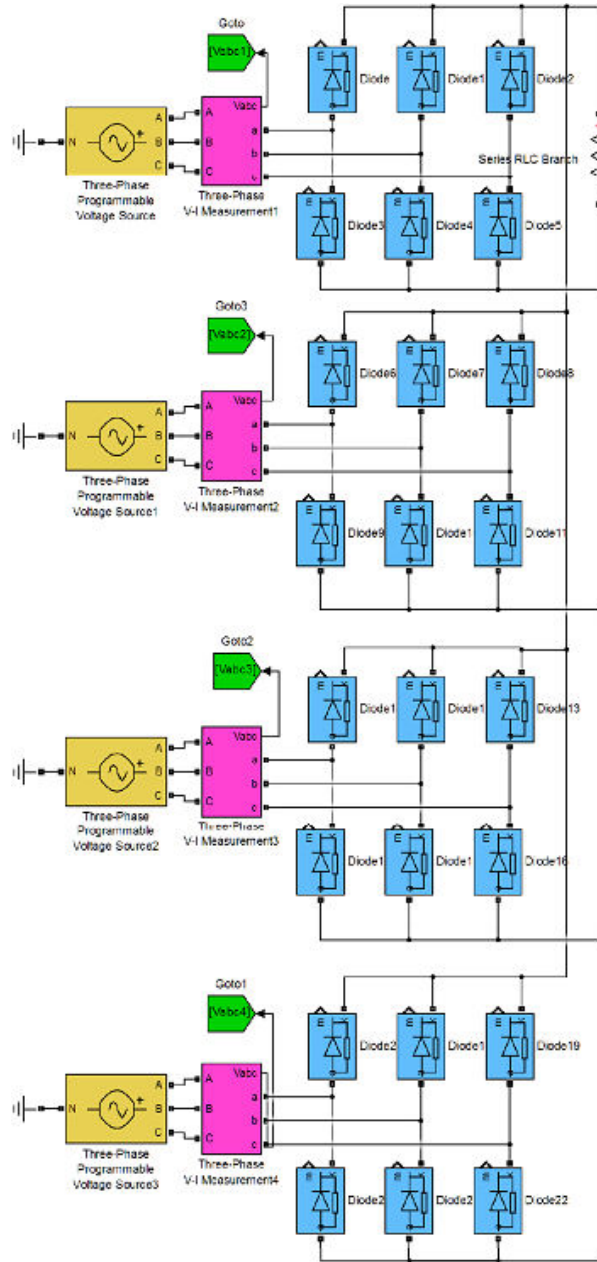

Fig. 32 Block diagram of 24-pulse rectifier SIMULINK model

TABLE VII
PARAMETERS OF 24-PULSE RECTIFIER

Parameters of AC sources	Source 1	Source 1	Source 1	Source 1
Vrms ph-ph	115V	115V	115V	115V
Phase shift	0°	15°	30°	45°
Frequency	400 Hz	400 Hz	400 Hz	400 Hz

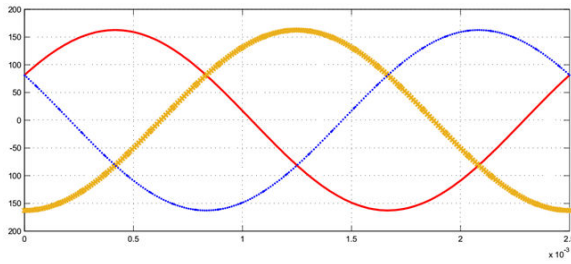

Fig. 33 Source No. 1 and No. 2 voltage characteristics

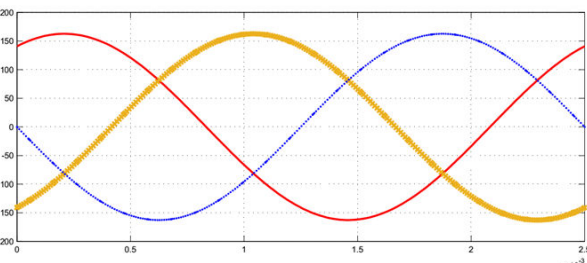
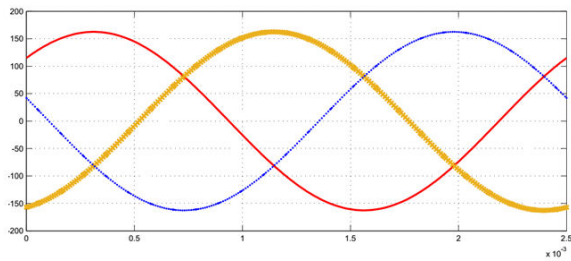

Fig. 34 Source No. 3 and No. 4 voltage characteristics

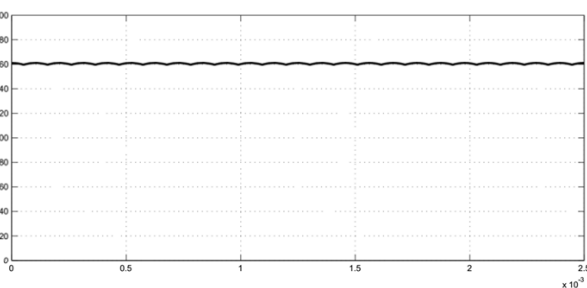
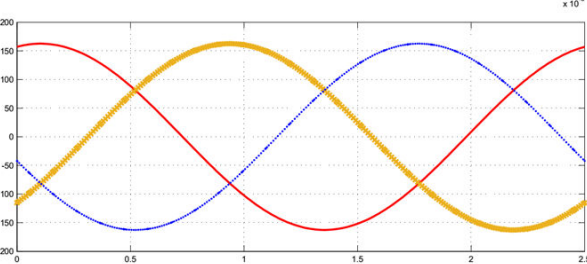

Fig. 35 Output voltage characteristics

The analysis of the graphs above can be concluded that the output voltage of the rectifier circuit is all the more stable the greater the number of pulses of the system. 6-pulse arrangement comprising six diodes produces significant harmonic distortion. 12-pulse system consists of two 6-pulse

circuits connected in series and the input AC voltage connected to the transformer, which has a phase shift between the outputs of 30° . This design system provides lower distortion rectified voltage. In contrast, systems 18- and 24-pulse provide much lower rectified voltage ripple. However, the higher number of pulses, the rectifier is more complicated in construction [15].

V. SUMMARY AND CONCLUSIONS

Basing on the literature review of PES multipulse converters of more electric aircraft MEA can be seen that advanced technologies, such as MEA/AEA, MET/MOET are only one from a few existing possible solutions available for development of more effective and ecologic advanced aircraft. The advanced technologies allow solving the key problem, associated with obtaining electrical energy economy and, what is related with it, decreasing of fuel usage and finally reduction of operating costs. In this purpose were started POA (*Power Optimised Aircraft*) program in 2002, which purpose was to increase efficiency of electrical energy including the most important aircraft systems such as propulsion system, pneumatic system, construction of actuators (EHA, EMA) and primarily generation of electrical power. This goal could be achieved by advanced progress made in the branch of Power Electronics (PES, PEC, EPS) [16]. Moreover, it should be noted that the MEA trend was known for a long time (II World War). But only the latest achievements in the field of advanced Power Electronic used in latest civil aircrafts (A-320, B-787) and military (F-22 Raptor, F-35) led to progressive implement of advanced technological solutions MEA/AEA in aviation.

Concluding from the simulation of example AC-DC rectifier model and analysis of output voltage and current characteristics from 6- and 12-pulse converter obtained, the level of regulation of 6-pulse AC-DC converter contained between voltage of 23,0-27,8V DC. However, 12-pulse converter keeps the level of regulation between voltage of 26,7-27,8V DC. Moreover, on this basis and literature review can be concluded AC-DC converters (12-pulse) are characterized by significantly better output parameters (Fig. 14), than in analogical systems being used on military aircrafts (Fig. 13). The show primarily more precise regulation and lower level of ripples of rectified DC. Additionally, despite usage of low-pass Pi filter in rectifiers (6-pulse), obtained quality of converted DC is not accurate in such range as in 12-pulse converters. Analogically, analyzing advanced multipulse converters (18- and 24-pulse) can be concluded these systems are characterized by significantly lower rectified DC voltage ripples (Figs. 31 and 35) in comparison with 6- and 12-pulse converters, what is presented in Figs. 25 and 28. Basing on the above can be drawn conclusions, that the cause of this is influence of such factors as: fluctuations of AC voltage, drops of converters and stabilizers voltage.

REFERENCES

- [1] M. Ronkowski, M. Michna, G. Kostro, F. Kutt, "Maszyny elektryczne wokół nas." Politechnika Gdańska, 2009-2010.

- [2] I. Moir, A. Seabridge, *"Aircraft Systems: Mechanical, Electrical, and avionics subsystems integration, 3rd Edition."* John Wiley & Sons, Ltd., 2008.
- [3] T. L. Skvarenina, *"The power electronics handbook."* CRC Press LLC, 2002.
- [4] E. Ruda, *"Koncepcja samolotu bardziej elektrycznego."* Praca magisterska, WSOSP, 2014.
- [5] A. Forsyth, A. Abdel-Hafez, *"A Review of More-Electric Aircraft."* 13th International Conference on Aerospace Sciences & Aviation Technology. ASAT-13, Cairo 2009.
- [6] L. Setlak, *"Overview of Aircraft Technology solutions compatible with the concept of MEA."* Technical Transactions. Electrical Engineering No. 1-E/2015, p. 67-76. Politechnika Krakowska, 2015.
- [7] T. L. Skvarenina, S. Pekarek, O. Wasynczuk, P.C. Krause, *"Simulation of a More-Electric Aircraft Power System Using an Automated State Model Approach."* Proceedings of the Intersociety Energy Conversion Engineering Conference, 1996.
- [8] J. I. Corcau, L. Ieana, L. Dinca, *"On using PEMFC for Electrical Power Generation on More Electric Aircraft."* International Journal of Electronics and Electrical Engineering 6/2012.
- [9] T. Citko, *"Energoelektronika – Układy wysokiej częstotliwości."* WPB Białystok, 2007.
- [10] M.E. Elbuluk, M.D. Kankam, *"Motor Drive Technologies for the Power-By-Wire (PBW) Program: Options, Trend and Tradeoff, Part II: Power Electronic Converter and Devices"*, IEEE Aerospace and Electronics Systems Magazine, Dec. 1995, pp.31-36.
- [11] A. Eid, M. Abdel-Salam, H. El-Kishky, T. El-Mohandes, *"Simulation and transient analysis of conventional and advanced aircraft electric power systems with harmonics mitigation."* Electric Power Systems Research 79 (2009).
- [12] K. Emandi, M. Ehsani, *"Aircraft power systems: technology, state of the art, and future trends"*, Aerospace and Electronic Systems Magazine, IEEE 2000.
- [13] Cpt David Pfahler, *"Air Force Power Requirements."* Standard Form 298 (Rev. 8-98), 2006.
- [14] L. Setlak, E. Ruda, *"Przegląd, analiza i symulacja wybranych komponentów elektroenergetycznego systemu zasilania EPS samolotu zgodnych z trendem samolotu zelektryfikowanego MEA."* Instytut Napędów i Maszyn Elektrycznych KOMEL. Zeszyty problemowe ZP-ME nr 3/2015 (107), str. 139-144, Katowice 2015.
- [15] G. Gong, U. Drogenik, J.W. Kolar, *"12-Pulse Rectifier for More Electric Aircraft Applications."* ETH Zurich, Power Electronic Systems Laboratory, ICIT 2003.
- [16] L. Setlak, *"Przegląd rozwiązań technologicznych samolotu zgodnych z koncepcją MEA."* Instytut Napędów i Maszyn Elektrycznych KOMEL. Zeszyty problemowe ZP-ME nr 3/2014 (103), str. 83-90, Katowice 2014.