

# Comparative Review of Modulation Techniques for Harmonic Minimization in Multilevel Inverter

M. Suresh Kumar, K. Ramani

**Abstract**—This paper proposed the comparison made between Multi-Carrier Pulse Width Modulation, Sinusoidal Pulse Width Modulation and Selective Harmonic Elimination Pulse Width Modulation technique for minimization of Total Harmonic Distortion in Cascaded H-Bridge Multi-Level Inverter. In Multicarrier Pulse Width Modulation method by using Alternate Position of Disposition scheme for switching pulse generation to Multi-Level Inverter. Another carrier based approach; Sinusoidal Pulse Width Modulation method is also implemented to define the switching pulse generation system in the multi-level inverter. In Selective Harmonic Elimination method using Genetic Algorithm and Particle Swarm Optimization algorithm for define the required switching angles to eliminate low order harmonics from the inverter output voltage waveform and reduce the total harmonic distortion value. So, the results validate that the Selective Harmonic Elimination Pulse Width Modulation method does capably eliminate a great number of precise harmonics and minimize the Total Harmonic Distortion value in output voltage waveform in compared with Multi-Carrier Pulse Width Modulation method, Sinusoidal Pulse Width Modulation method. In this paper, comparison of simulation results shows that the Selective Harmonic Elimination method can attain optimal harmonic minimization solution better than Multi-Carrier Pulse Width Modulation method, Sinusoidal Pulse Width Modulation method.

**Keywords**—Multi-level inverter, Selective Harmonic Elimination Pulse Width Modulation, Multi-Carrier Pulse Width Modulation, Total Harmonic Distortion, Genetic Algorithm.

## I. INTRODUCTION

NOWADAYS, the concern of many ongoing researches showing the multilevel inverters can be assimilating into many medium and high voltage industrial applications such as Flexible AC transmission system (FACTS) equipment, HVDC, motor drives, and renewable energy systems [1]. Multi-level inverter is a well-known power conversion process to provide the Step output voltage thus it similar as sine wave with minimum value of THD [2]. Advantage of multi-level inverter is mainly related with the traditional two-level voltage inverter, it produce step output voltage, it provides high power quality, lower harmonic value, enhanced electromagnetic compatibility and lower switching losses [3]. Generally multi-level inverter has been categorized into three types: Diode-Clamp Multi-Level Inverter (DCMLI), Flying Capacitor

Multi-Level Inverter (FCMLI), and Cascaded H-Bridge Multi-Level Inverter (CHBMLI) [4].

In multi-level inverter, harmonic problem is the important one with distress the output voltage and increased level of switching strategy [5]. Consequently numerous methods like Sinusoidal Pulse Width Modulation (SPWM), Multi-Carrier Pulse Width Modulation (MCPWM) and Selective Harmonic Elimination Pulse Width Modulation (SHE-PWM) are implemented for harmonic elimination in multi-level inverter [6]. Multi-Carrier Pulse Width Modulation (MCPWM) strategies is widely used, because it can be easily implemented to low voltage modules [7]. Normally MCPWM can be categorized as Level Shifted PWM (LS-PWM) and Phase Shifted PWM (PS-PWM) methods [8]. The LS-PWM is characterized into Phase Disposition (PD), Phase Opposition Disposition (POD) and Alternative Phase Opposition Disposition (APOD) [9]. Equate the above all methodology, APOD method is the most major process to express harmonics are centered as sidebands around the carrier frequency [10]. Merits of APOD approach in MCPWM have no harmonics occur at the carrier frequency and higher band width [11]. Among all the above method, SHEPWM is only method for selecting proper switching angles to eliminate low-order harmonics and minimize the THD of output voltage [12]. The main objective of SHEPWM method is to determine the switching angles to specific lower order harmonics suppressed in the output voltage of the inverter to achieve desired fundamental component with possible minimum THD [13]. In SHEPWM method operate a set of non-linear transcendental equations as the fitness or objective function that includes many local optimal solutions [14]. Moreover SHE problem can be solved in three ways such as analytical approach based on resultant theory method [15], numerical iterative techniques, such as Newton-Raphson method [16] and evolutionary algorithms [17] such as Genetic Algorithm (GA), Particle Swarm Optimization (PSO) [18] and etc. As clarified before, evolutionary algorithm such as GA and PSO algorithm can be programmed with SHE for employs to find the fitness function for achieve the desired fundamental component and remove selective harmonics in the waveform of output voltage effectively [19]. Various fitness functions can be employed for SHE problem [20], which the purpose of all approach is the same.

In this paper, presented the comparative analysis on MCPWM, SPWM and SHEPWM method for valuation of harmonic elimination and shown the THD result in CHBMLI. In consequence simulation results can be processed in 7-level

M.Suresh Kumar is doing PG Power Electronics and Drives at K. S. Rangasamy College of Technology, Tiruchengode 637215 Tamilnadu (mobile: 9025291195; e-mail: sureshmeped13@gmail.com).

Dr. K. Ramani is working as Associate Professor, Department of Electrical and Electronics Engineering, K.S.Rangasamy college of Technology, Tiruchengode 637215 (mobile: 9788518536 e-mail: kreee82@gmail.com).

CHBMLI using MCPWM method, 9-level CHBMLI using SPWM and 9-level, 11-level CHBMLI using SHEPWM method to show the validity of the modulation techniques. Simulation result of MCPWM, SPWM and SHE method can be done through in MATLAB/Simulink tool box.

II. MULTI-LEVEL INVERTER TOPOLOGY

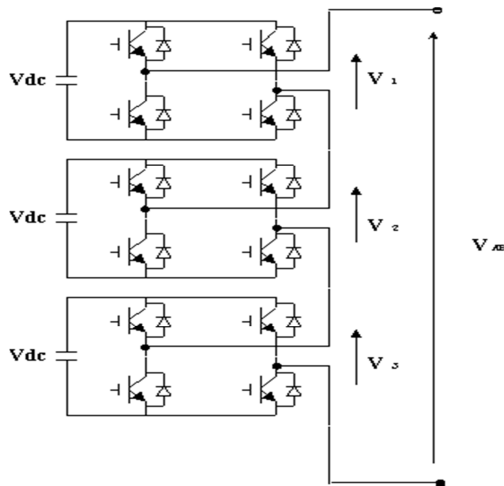

Fig. 1 Single Phase Cascaded H-Bridge Multi-Level Inverter

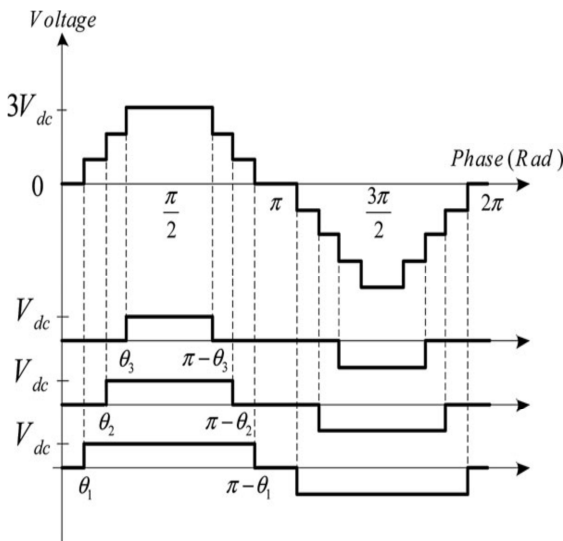

Fig. 2 Staircase Output Voltage Waveform of Cascaded H- Bridge Multi-Level Inverter

A CMLI equated with capacitor clamped and diode clamped multilevel inverter, it shown that the benefits such as modularity layout, fewer components, absence of extra clamping diodes or voltage balancing capacitors and the number of output voltage levels can be easily adjusted [21]. In CHBMLI, the period of switches turn ON and OFF process can be done in only once per cycle so it simply solving the switching loss problem [22]. Fig. 1 shows the CHBMLI have series of H bridge (single-phase full-bridge) inverter units. Each full-inverter bridge can provide three different voltage

outputs:  $+V_{dc}$ , 0, and  $-V_{dc}$ . Although, CHBMLI produce staircase output voltage waveform as shown in Fig. 2. As a result, the voltage level of CHBMLI is measured in  $2S + 1$ , where  $S$  is the number of dc sources [23]. Fig. 2 shows the output voltage waveform of a 7-level CHBMLI with three isolated dc sources ( $S = 3$ ).

III. CONFIGURATION OF MULTICARRIER AND SELECTIVE HARMONIC ELIMINATION PWM METHOD

A. Multicarrier PWM Method

The main principle of the multicarrier PWM method is obtained on the comparison of a sinusoidal reference waveform with triangular carrier waveforms [24]. As a result  $m-1$  carriers have required to producing  $m$  levels of carrier waveform and also the carriers are present in the continuous bands are consider as almost Zero reference value. Hence carriers have the same amplitude  $A_c$  and the same frequency  $f_c$  in the required waveform. The sine reference waveform takes a frequency  $f_r$  and  $A_r$  for the peak to peak value of the reference waveform [25]. Therefore this method can be considered by the two subsequent parameters called amplitude modulation index  $m_a$  and frequency modulation index ( $m_f$ ):

$$m_a = \frac{2A_r}{(m-1)A_c} \tag{1}$$

$$m_a = \frac{2A_r}{A_c} \tag{2}$$

$$m_f = \frac{f_c}{f_r} \tag{3}$$

And so in the MCPWM, APOD can be instigated in the CHBMLI for the switching generation scheme. Consequently APOD-PWM, all carrier waveform is obtainable along with phase and its neighboring carrier wave by 180 degree as exposed in Fig. 3. Altogether the carrier waveform have same frequency, same amplitude but compare each carrier waveform to neighbor carrier waveform is phase shifted 180 degree. Likewise Even carrier waveforms are in phase but compare to Odd carrier waveform are out of phase shift 180 degree in odd carrier waveform.

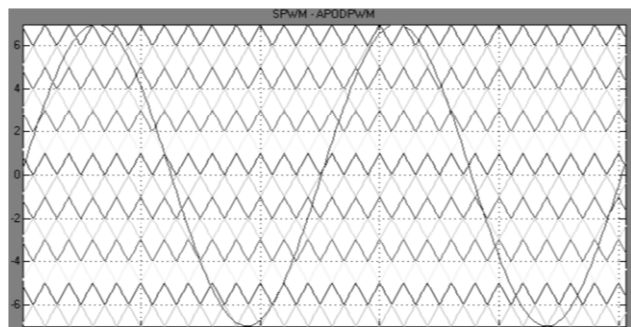

Fig. 3 Carrier and Sinusoidal Waveform of APODPWM

*B. Sinusoidal Pulse Width Modulation Method*

Although the SPWM method, the waveform contains several number of harmonics order in the phase voltage waveform, the dominant ones other than the fundamental are of order  $n$  and  $n \pm 2$  where  $n$  can be described as

$$n = f_c/f_m \tag{4}$$

In the SPWM method, generation of the desired output voltage is completed by relating the desired reference waveform (modulating signal) with a high-frequency triangular carrier wave [26]. Fig. 4 shows that the switching pulse generation can be formed completely for made the combination of carrier pulse and sinusoidal pulse waveform. While the modulating signal is a sinusoid of amplitude  $A_m$ , and the amplitude of the triangular carrier is  $A_c$ , the ratio is given by

$$m = A_m/A_c \tag{5}$$

where  $m$  is known as the modulation index. Therefore, in SPWM methods have to control the modulation index for controls the amplitude of the applied output voltage.

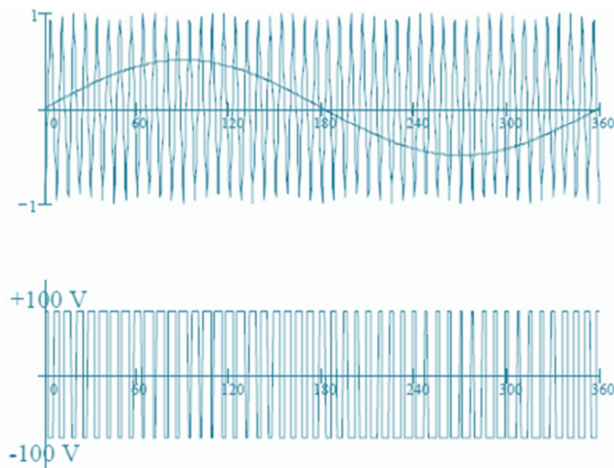

Fig. 4 SPWM with  $f_c/f_m$

The subsequent square waveform contains a model of the desired waveform in its low frequency components, with the higher frequency components presence at frequencies of a close to the carrier frequency.

*C. Selective Harmonic Elimination PWM Method*

In this paper SHE-PWM method, GA and PSO algorithm are implemented for calculating the non-linear transcendental equation for determine the proper switching angels to CHBMLI. Using SHE-PWM method, CHBMLI produces output phase voltage with proper switching angles. To begin with output phase voltage have harmonics is presented [29]. Furthermore in case of output phase voltage, even harmonics is zero but odd harmonics are critical to calculate. Therefore SHEPWM method can used Fourier expansion for the purpose

of to calculate the odd harmonics in the phase voltage. Accordingly Fourier analysis of output phase voltage is given by

$$V(\omega t) = \sum_{n=1}^{\infty} V_n \cos(n\omega t) + V_n \sin(n\omega t) \tag{6}$$

Considering the output voltage and amplitude of dc sources is shown in Fig. 2, it would be written as:

$$V(\omega t) = \sum_{n=1}^{\infty} V_n \sin(n\omega t) \tag{7}$$

where  $V_n$  is the amplitude and voltage waveform of  $n_{th}$  harmonic component. In SHE-PWM method switching angles can be limited in zero and  $\pi/2$ . Consequently  $V_n$  develops to describe odd and even function is given as,  $V_n = \frac{4}{n\pi} V_{dc} \sum_{i=1}^s \cos(na_i)$ ,  $n=odd$  and  $V_n = 0$ ,  $n=even$ . The purpose of SHEPWM method in CMLI is used to eliminate low order harmonics while other harmonics are eliminated by using filter [27]. In this paper SHEPWM can be implemented for eliminate 3<sup>rd</sup>, 5<sup>th</sup>, 7<sup>th</sup> harmonics [28]. Similarly low order harmonics can be solved the transcendental nonlinear equation of switching angles are provided as follows,

$$V_n = \frac{4}{\pi} V_{dc}(a_1) + V_{dc}(a_2) + V_{dc}(a_3) \tag{8}$$

$$V_5 = \frac{4}{5\pi} V_{dc}(5a_1) + V_{dc}(5a_2) + V_{dc}(5a_3) \tag{9}$$

$$V_7 = \frac{4}{7\pi} V_{dc}(7a_1) + V_{dc}(7a_2) + V_{dc}(7a_3) \tag{10}$$

In equation (9) and (10) are fixed to be zero to eliminate fifth and seventh harmonics respectively. Using modulation index to represent the fundamental voltage of  $V_1$  is given as

$$M = \frac{V_1}{sV_{dc}} \tag{11}$$

Substituting (8), (9), (10) in (11) to get nonlinear equation (12) is given by,

$$\left. \begin{aligned} M &= \frac{4}{3\pi} \cos(a_1) + \cos(a_2) + \cos(a_3) \\ 0 &= \cos(5a_1) + \cos(5a_2) + \cos(5a_3) \\ 0 &= \cos(7a_1) + \cos(7a_2) + \cos(7a_3) \end{aligned} \right\} \tag{12}$$

Now optimal switching angles can be named  $a_1, a_2, a_3$  must be found depend upon modulation index. Therefore, PSO algorithm can be programmed for finding optimal switching value for eliminating lower order harmonics and maintained their fundamental voltage value.

*D. Genetic Algorithm*

A GA is a computational model to find the precise solution for the optimization problems based on genetics and evolution. In GA approach, Effortlessness of the operation and Power of effect are two of the main attractions for calculate the optimization problem. GA can be used to enhance the order of carrier waveform in the PWM so result can be shown to minimize the Total Harmonic Distortion [30]. Moreover GAs can use probabilistic evolution rules to attendant their search toward regions of the entire search space. Fig. 5 shows that the

GA flow chart for measuring the quantity of optimal switching angles for eliminating the lower order harmonic and minimizing the THD valve. Though GA is a tool can be used as random select, they have been theoretically and empirically established to deliver robust solution in complex search spaces. The GA can be applied as follows:

- i. Proper Selection of binary or floating string.
- ii. Estimate the number of definite variables to the optimization problem. And the specific variables can be related to the number of controlled switching angles.
- iii. Set the initial population size depend upon the rate of convergence.
- iv. The fitness of every chromosome is assessed by the cost function. Since, the objective of the cost function depend upon the minimization of harmonics order with relates the switching angles
- v. The cost function for a nine level inverter is,

$$f(\theta_1, \theta_2, \theta_3) = \frac{|V_7| + |V_9|}{|V_1|} \quad (13)$$

#### E. Particle Swarm Optimization Algorithm

The particle swarm optimization (PSO) is an optimization technique first introduced by Kennedy and Eberhart was inspired by the sociological behavior of food searching principles such as group of birds and fish manner. [17]. And PSO is an effective and fastest optimization algorithm for define the optimal solution of the non-linear problems. Every time particles can be modernized for finding the feasible solution with respect of position and velocity vectors. In enter search space, position vectors said to be  $X_i = [x_1, x_2, \dots, x_D]$  and the velocity vector  $V_i = [v_1, v_2, \dots, v_D]$  [13]. Each particle can develops the search criteria depend upon the present best value, previous best value and experience of neighboring best value. Using (13) and (14) modify the particles with respect of velocity and position vectors. Therefore the velocity and position equation is given as

$$V_{id}^{k+1} = V_{id}^k + c_1 r_1^k (p_{id}^k - x_{id}^k) + c_2 r_2^k (g_{best}^k - x_{id}^k) \quad (14)$$

$$X_{id}^{k+1} = x_{id}^k + V_{id}^{k+1} \quad (15)$$

where  $c_1$  and  $c_2$  are the constraints of cogitative and social task respectively. And  $r_1$  and  $r_2$  are random values for the initial solution of PSO and its range is within 0 to 1.

- Step 1. Initialize the population with proper locations and Range of velocities.
- Step 2. Estimate the fitness of the individual particle in the entire swarm (PBest).
- Step 3. Calculate the fitness of individual global particles in the entire swarm (GBest).
- Step 4. Modify PBest and GBest Position based on updating velocity constraints
- Step 5. Update the particles position at the end of every iteration.
- Step 6. Terminate the iteration process if the condition can get the Optimal value
- Step 7. Go to Step 2.

In above all steps to show the estimation of optimal switching value by PSO and its process can be defined in subsequent flow chart. Fig. 6 shows that the PSO algorithm flow chart for determining the quantity of optimal switching angles for eliminating the lower order harmonic and minimizing the THD valve.

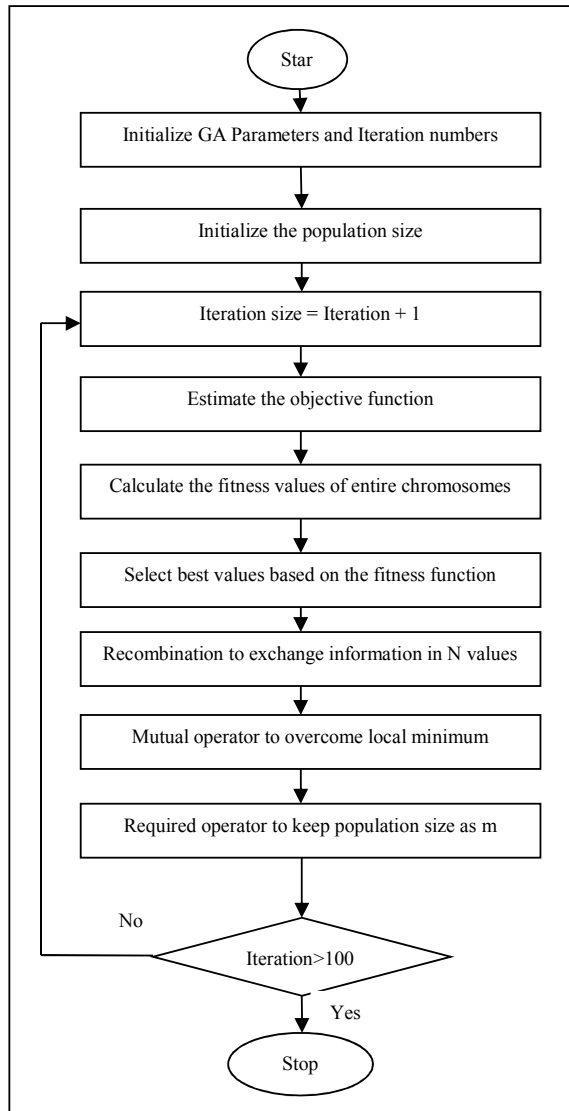

Fig. 5 GA Flow Chart

#### IV. INVESTIGATION OF SIMULATION RESULTS

Here compare and analysis the simulation result of MCPWM method, SPWM method and SHEPWM method of CHBMLI with using MATLAB/Simulink system. In MCPWM technique can be used APOD approach in 7-level CHBMLI, SPWM can be exposed 9-level CHBMLI, SHEPWM can be demonstrate the result of using GA and PSO algorithm in 9-level, 11-level CHBMLI respectively.

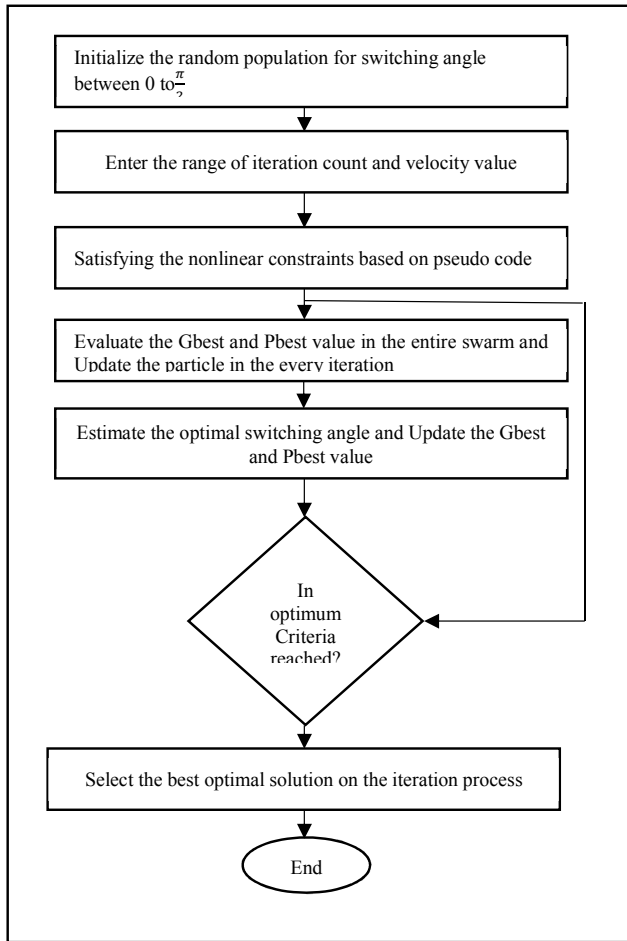

Fig. 6 PSO Flow Chart

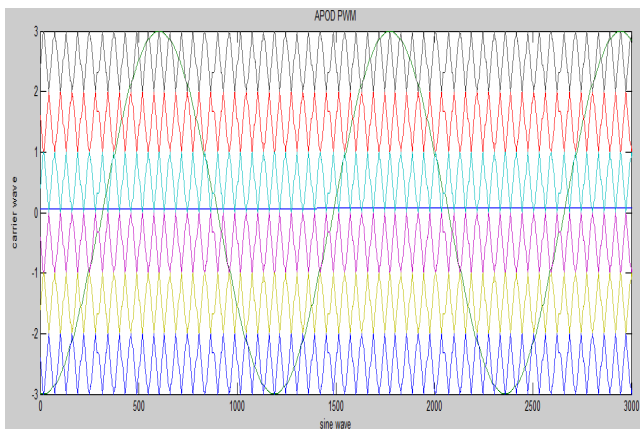

Fig. 7 Output Carrier and Sinusoidal Waveform of APOD approach for 7-level CHBMLI

*A. Multi Carrier Based Seven Level CHBMLI*

Fig. 7 shows output carrier and sinusoidal waveform of APOD approach for 7-level CHBMLI. Fig. 8 shows the switching pulse waveform of APOD approach used in 7-level CHBMLI. In Fig. 9 shows that the magnitude of output phases voltage of 7 level CHBMLI by using MCPWM method. In

Fig. 10 shows that the THD value of 7 level CHBMLI by Fast Fourier Transform analysis using MCPWM method.

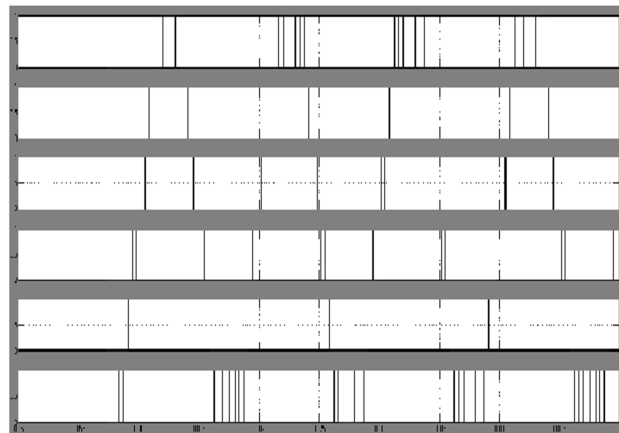

Fig. 8 Switching Pulse Waveform of 7-level CHBMLI using APOD approach

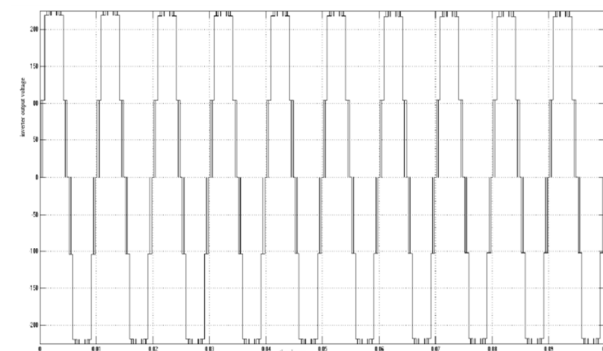

Fig. 9 Output Phase Voltage of 7-Level CHBMLI using MCPWM

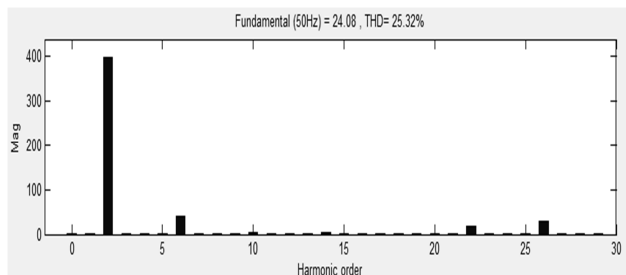

Fig. 10 THD result of 7- Level CHBMLI using MCPWM

*B. Sinusoidal PWM Based Nine-level CHBMLI*

Figs. 11 and 12 shows that the 9-level CHBMLI output waveform and harmonic spectrum of 9-level CHBMLI by SPWM method. From the harmonic spectrum, result shows that the THD value by SPWM is 36.17%.

*C. SHEPWM Method-Genetic Algorithm Based Nine-level CHBMLI*

Figs. 13 and 14 shows that the output waveform and the frequency spectrum of 9-level CHBMLI by using SHEPWM method with GA approach.

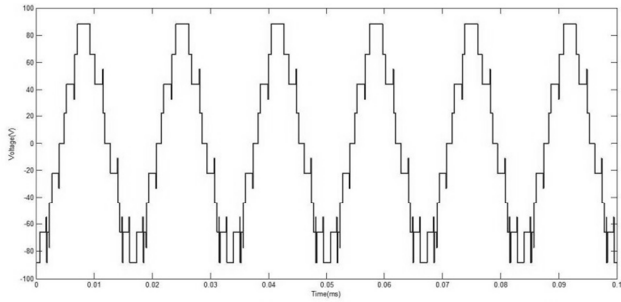

Fig. 11 Output voltage for 9-level CHBMLI by SPWM

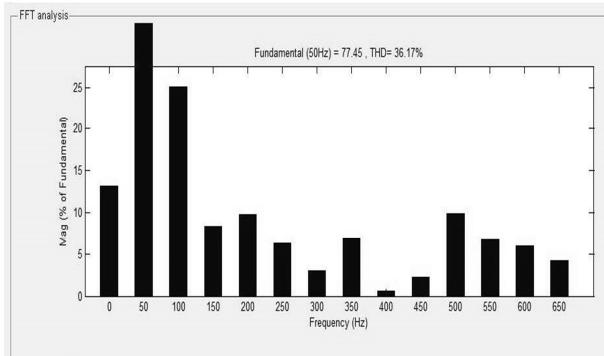

Fig. 12 Harmonic spectrum of 9-level CHBMLI by SPWM

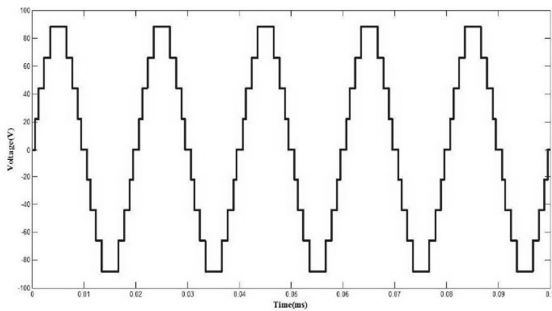

Fig. 13 Output voltage for 9-level CHBMLI by SHEPWM with GA

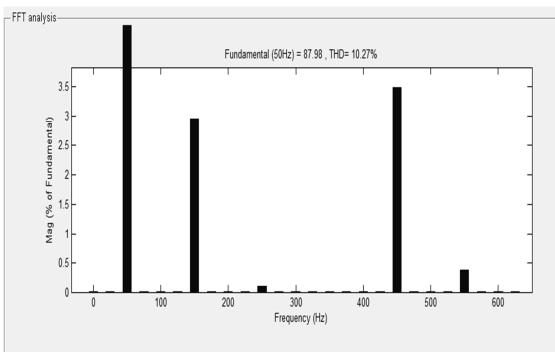

Fig. 14 Harmonic spectrum of 9-level inverter by SHEPWM with GA

Fig. 14 shows that that the harmonic spectrum of THD value by SHEPWM is 10.27%.

*D. SHEPWM Method-PSO Algorithm Based 9-level CHBMLI*

Fig. 15 shows that the harmonic order for the output phase voltage of CHBMLI using PSO. Fig. 16 shows that the output pulse voltage of CHBMLI for the given Modulation Index= 0.5 and Load Phase Angle=120 degree. Fig. 17 shows that the output current for the given modulation index value MI=0.3 at Load Phase Angle =120 degree

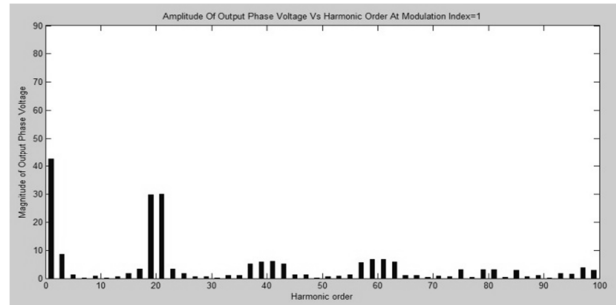

Fig. 15 Harmonic Order versus the Magnitude Phase Output Voltage

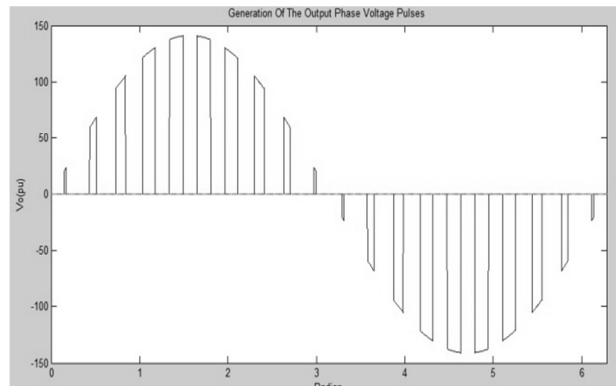

Fig. 16 Output Phase Voltage of MI=0.5 at Load Phase Angle=120 degree

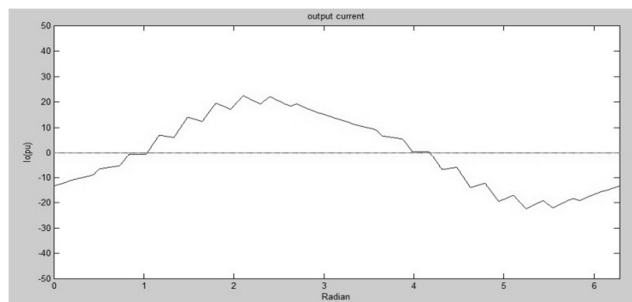

Fig. 17 Output Phase Voltage of MI=0.5 at Load Phase Angle=120 degree

Table I shows that the simulation result of PSO algorithm in SHEPWM method, it shows RMS voltage and THD value for the various modulation index values.

TABLE I  
THD AND OUTPUT VOLTAGE VALUE AT VARIOUS MODULATION INDEX

Modulation Index	RMS output voltage ( $V_{ORMS}$ )	RMS value of output voltage fundamental component	% $V_{oTHD}$
0.2	40.8855	16.7162	22.2
0.3	50.2887	25.2896	17.8
0.4	58.1488	33.8128	13.9
0.5	65.1517	42.4474	11.4
0.6	71.1688	50.6500	9.80
0.7	76.7500	58.9139	8.30
0.8	82.1900	67.5671	6.98
<b>0.9</b>	<b>87.4450</b>	<b>76.4662</b>	<b>5.57</b>

Table II shows that the THD value of MCPWM, SPWM and SHEPWM based GA, PSO algorithm for the CHBMLI.

TABLE II  
THD VALUE OF CHBMLI USING MCPWM, SPWM, SHEPWM METHOD BASED GA AND PSO ALGORITHM

METHODS	Levels of CHBMLI	$V_{oTHD}$ %
MCPWM	7-level CHBMLI	25%
SPWM	9-level CHBMLI	36%
SHEPWM based GA	9-level CHBMLI	10%
SHEPWM based PSO	11-level CHBMLI	5.5%

In Fig. 18 shows that the THD value of MCPWM, SPWM, and SHEPWM method based GA, PSO algorithm in the CHBMLI.

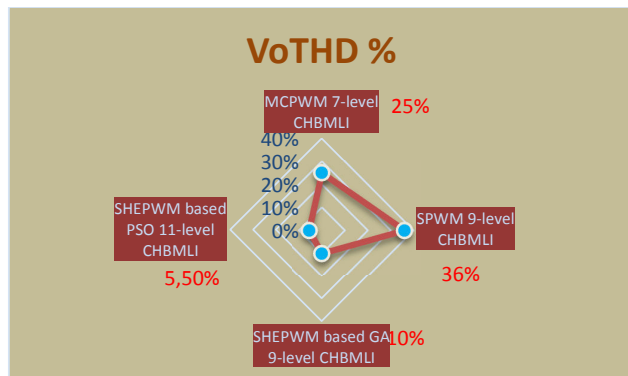

Fig. 18 THD value of Modulation Techniques in the CHBMLI

## V. CONCLUSION

In this paper, proposed the comparison and analysis the simulation result of modulation techniques such as MCPWM, SPWM and SHEPWM Based GA, PSO approach has been suggested in the CHBMLI. In this comparative review to illustrate the MCPWM, SPWM and SHEPWM based GA, PSO algorithm can be used to solve the optimized harmonics problem and enhanced the power quality for the high power application system. As a result, this all modulation method can demonstrate proficient results for attain the global solution and also give better THD results in the CHBMLI.

## ACKNOWLEDGMENT

The authors want to thank AICTE New Delhi for the support given to this work through the research work and awarded the "Career Award for Young Teachers" **Dr.K.Ramani** (F.No.11.8/AICTE/RIFD/CAYT/POL-1/2013-14)

## REFERENCES

- [1] G. Holmes and T. A. Lipo, Pulse Width Modulation for Power Converters. Piscataway, NJ: IEEE Press, 2003.
- [2] S. Kouro, J. Rebolledo, and J. Rodriguez, "Reduced switching-frequency modulation algorithm for high-power multilevel inverters," IEEE Trans. Ind. Electron. vol. 54, no. 5, pp. 2894–2901, Oct. 2007.
- [3] H. S. Patel and R. G. Hoft, "Generalized harmonic elimination and voltage control in thyristor inverters: Part I—Harmonic elimination," IEEE Trans. Ind. Appl., vol. IA-9, no. 3, pp. 310–317, May/June 1973.
- [4] H. S. Patel and R. G. Hoft, "Generalized harmonic elimination and voltage control in thyristor inverters: Part II—Voltage control technique," IEEE Trans. Ind. Appl., vol. IA-10, no. 5, pp. 666–673, Sep/Oct. 1974.
- [5] W. Fei, X. Du, and B. Wu, "A generalized half-wave symmetry SHE-PWM formulation for multilevel voltage inverters," IEEE Trans. Ind. Electron. vol. 57, no. 9, pp. 3030–3038, Sep. 2010.
- [6] P. N. Enjeti, P. D. Ziogas, and J. F. Lindsay, "Programmed PWM techniques to eliminate harmonics: A critical evaluation," IEEE Trans. Ind. Appl. vol. 26, no. 2, pp. 302–316, Mar./Apr. 1990.
- [7] V. G. Agelidis, et al., "Multiple Sets of Solutions for Harmonic Elimination PWM Bipolar Waveforms: Analysis and Experimental Verification," IEEE Trans. Power Electron., vol. 21, no. 2, pp.415–421, March 2006.
- [8] A. I. Maswood, et al., "A Flexible Way to Generate PWM-SHE Switching Pattern using Genetic Algorithm," IEEE Applied Power Electronics (APEC) Conf. Proc., Anaheim, California, USA, Vol. 2, 2001, pp. 1130 – 1134.
- [9] A. Sayyah, et al., "Optimization of THD and Suppressing Certain Order Harmonics in PWM Inverters using Genetic Algorithms," Proc. of IEEE International Symposium on Intelligent Control, Germany, Oct. 2006, pp. 874 – 879.
- [10] K. Sundareswaran, et al., "Inverter Harmonic Elimination through a Colony of Continuously Exploring Ants," IEEE Trans. Ind. Elect., vol. 54, no. 5, pp.2558-2565, October 2007.
- [11] Ayoub Kavousi, et al., "Application of the Bee Algorithm for Selective Harmonic Elimination Strategy in Multilevel Inverters," IEEE Trans. Power Electron., vol. 27, no. 4, pp.1689-1696, April 2012.
- [12] J. Kennedy, R. Eberhart, "Particle Swarm Optimization," (ICNN'95), Vol. IV, pp.1942- Proceedings of IEEE International Conference on Neural Networks 1995.
- [13] Mohamed Azab, "Global maximum power point tracking for partially shaded PV arrays using particle swarm optimization", International Journal of Renewable Energy Technology, vol. 1, no. 2, pp. 211-235, Inderscience Enterprises Ltd- UK, 2009.
- [14] J. Hereford, M. Siebold, "Multi-robot search using a physically-embedded particle swarm optimization", International Journal of Computational Intelligence Research, Vol. 4, No. 2, pp.197–209, 2008.
- [15] M. Clerc and J. Kennedy, "The particle swarm: Explosion, stability and convergence in a multi-dimensional complex space," IEEE Trans. Evol. Comput. vol. 2, no. 3, pp. 91–96, Jun. 1998.
- [16] K. Ramani and A. Krishnan SMIEEE "An Estimation of Multilevel Inverter Fed Induction Motor Drive." International Journal of Reviews in Computing. E-ISSN: 2076-331X© 2009 IJRIC.
- [17] J. Kennedy and R. Eberhart, Swarm Intelligence. San Mateo, CA: Morgan Kaufmann, 2001.
- [18] K. Ramani and A. Krishnan, Switching Pattern Selection Scheme Based 11 levels Flying Capacitor Multilevel Inverter fed Induction Motor, European Journal of Scientific Research, Vol. 48, No. 1, 2010, pp. 51-62.
- [19] L. M. Tolbert, F. Z. Peng and T. G. Habetler. 1999. Multilevel converters for large electric drives. IEEE Transactions on Industry Applications. 35(1): 36-44, January / February.
- [20] Neelashetty Kashappa and Ramesh Reddy K. 2011. Performance of Voltage Source Multilevel Inverter -Fed Induction Motor Drive Using Simulink. ARPN Journal of Engineering and Applied Sciences, ©2006-2011. 6(6): 50-57.

- [21] Mr. G. Pandian and Dr. S. Rama Reddy. 2008. Implementation of Multilevel Inverter-Fed Induction Motor Drive. Journal of industrial technology. Vol.24.
- [22] Yang Han, Lin Xu, Gang Yao, Li-Dan Zhou, Mansoorand Chen Chen. 2009. Operation Principles and Control Strategies of Cascaded H-bridge Multilevel Active Power Filter. Electronics and Electrical Engineering, ISSN 1392 - 1215 2009. 3(91).
- [23] S. Mohamed Yousuf, P. Vijayadeepan and S. Latha.2012. The Analysis of Multi-Carrier PWM Control Techniques for Neutral Clamped Multilevel Z-Source Inverter. International Conference on Computing and Control Engineering (ICCE 2012), 12 and 13 April.
- [24] E. Sambath, S.P. Natarajan and C.R. Balamurugan. 2012. Performance Evaluation of Multi Carrier Based PWM Techniques for Single Phase Five Level HBridge Type FCMLI. IOSR Journal of Engineering(IOSRJEN) ISSN: 2250-3021. 2(7): 82-90.
- [25] S. Malathy and U. Shajith Ali. Performance Analysis of Multi-Carrier PWM Based Cascaded Multilevel Inverter. GJPAST | MAR - APR 2012 ISSN: 2249-7188.
- [26] Muhammad H Rashid. 1996. Power Electronics Circuits Devices and Applications. 2nd Ed. PHI, NewDelhi, India. pp. 566-572.
- [27] Leon M. Tolbert, IEEE, Fang Zheng Peng. 2000.IEEE and Thomas G. Habetler. IEEE Multilevel PWM Methods at Low Modulation Indices IEEE Transactions on Power Electronics. 15(4), July.
- [28] G. Mahesh, Manivanna Kumar and S. Ram Reddy2011.Simulationand Experimental Results of 7-Level Inverter System. Research Journal of Applied Sciences, Engineering and Technology. 3(2): 88-95,ISSN: 2040-7467.
- [29] J. Rodriguez, S. Bernet, B. Wu, J. O. Pontt, and S. Kouro, "Multilevel voltage-source-converter topologies for industrial medium voltage drives," IEEE Trans. Ind. Electron., vol. 54, no. 6, pp. 2930-2945, Dec.2007.
- [30] F. Z. Peng, "A generalized multilevel inverter topology with self voltage balancing," IEEE Trans. Ind. Appl., vol. 37, no. 2, pp. 611-618, Mar./Apr.2001.



**M. Suresh Kumar** was born in Salem District, Tamilnadu, India. He received his B.E degree in Electrical and Electronics Engineering in 2013 from Government college of Engineering-Bargur, Krishnagiri District; At present, he pursuing his M.E degree in Power Electronics and drives from K.S.Rangasamy college of Technology-Tiruchengode, Namakkal District,India. His current research interests involved in Multi-level Inverters, Optimization Techniques and Photo Voltaic system.



**Dr. K. Ramani** was born in Vedaranyam Nagapattinum District. He is Under Graduated in 2004 from Bharathiar University, Coimbatore and Post Graduated in 2006 at Anna University, Chennai-25. He is awarded Ph.D degree in 2012 from Anna University, Chennai-25. He is currently working as a Senior Lecturer, Electrical & Electronic Engineering Department, University Technology PETRONAS, Malaysia. He has more than ten year working experience as a Associate Professor in the department of EEE at K.S.Rangasamy College of Technology, Tiruchengode,India. He has published 58 International/National Conferences, Journals. His research interest involves in power electronics, multilevel inverters, modeling of induction motor and optimization techniques. He is Editor in chief, Journal of Asian Scientific research and International and Journal of Advances in Engineering and Technology (USA). He is reviewers in IEEE Transaction of Industrial Electronics, International Review of Electrical Engineering, International Journal of the Physical Sciences and various IEEE international conferences. He obtained best teacher award in KSRCT in the academic year 2011-12. Also he obtained *Career Award for Young Teachers* from AICTE, New Delhi (F.No.11.8/AICTE/RIFD/ CAYT/POL-1/2013-14). He is life member of ISTE, IETE and MIEEE.