

# Behavior of the Masonry Infill in Structures Subjected to the Horizontal Loads

Nawel Mezigheche, Abdelhacine Gouasmia, Allaeddine Athmani, Mouloud Merzoud

**Abstract**—Masonry infill walls are inevitable in the self-supporting structures, but their contribution in the resistance to earthquake loads is generally neglected in the structural analyses. The principal aim of this work through a numerical study of masonry infill walls behavior in structures subjected to horizontal load is to propose by finite elements numerical modeling, a more reliable approach, faster and close to reality. In this study, 3D Finite Element Analysis was developed to study the behavior of masonry infill walls in structures subjected to horizontal load; the finite element software being used was ABAQUS, it is observed that more rigidity of the masonry filling is significant, more the structure is rigid, we can so conclude that the filling brings an additional rigidity to the structure not to be neglected; it is also observed that when the framework is subjected to horizontal loads, the framework separates from the filling on the level of the tended diagonal.

**Keywords**—Finite element, Masonry infill walls, Rigidity of the masonry, Tended diagonal.

## I. INTRODUCTION

THE catastrophic experiments in Algeria show that the seismic behavior of the structures with masonry filling was not always very powerful, it is therefore necessary to develop our comprehension of this material.

From research undertaken these last years, it was shown that the fillings can take part in the resistance and the rigidity of the structures [1]-[3]; it was also shown that the presence of the fillings can have a significant contribution to the dissipation of the capacity of energy.

In more of public works concerning the use of the anisotropic continuous models, masonry is considered as a composite material or the effect of the joints of mortar and cracking are taken into account in a way distributed in the mass of material, these models of the total type are not always able to represent all the mechanisms of rupture characterizing masonry especially those associated the friction and the slip.

## II. FINITE ELEMENT ANALYSIS

In the finite element method based on displacement, structure is divided into parts, each one with its own material and properties, for which the relationship between the nodal forces and displacements can be derived. The assembly of these elements and application of loads and boundary

N. Mezigheche is with the University of Badji Mokhtar, Annaba, Algeria (corresponding author phone: +213697490453; e-mail: nawel.mezigheche@lgc-univ-annaba.dz).

A. Gouasmia, A. Athmani, and M. Merzoud are with the University of Badji Mokhtar, Annaba, Algeria, (e-mail: gouasmia\_abdelhacine@yahoo.fr, allaeddine.athmani@gmail.com, mouloud.merzoud@univ-annaba.org).

conditions give results in a system of equations describing the structure equilibrium, which must be solved to obtain nodal displacements of the structure, and stresses, strains in the integration points.

In this study, 3D Finite Element Analysis was developed to study the behavior of masonry infill walls in structures subjected to horizontal load; the finite element software being used was ABAQUS.

ABAQUS is a general commercial computer code. It is particularizes by its large field of action that ranges from thermo- acoustics through fluid mechanics. Version 6.5 witch we used consists of three different modules:

CAE ABAQUS: These modules permit the definition and visualization of different simulations. Initially, the problems are defined by geometric entities for which one the physical properties will be defined

Standard ABAQUS: This module is the default calculation code dedicated to the quasi-static calculations, linear or not, thermal, acoustic, the calculation algorithm is based on iterative calculations to achieve the reach balance system equilibrium at each time increment.

ABAQUS Explicit: The explicit module is often used for dynamic calculations. Unlike implicit code the explicit is not an iterative algorithm. This algorithm is based on a very large number of very short increments defined by the propagation speed of an elastic wave.

Before undertaking models of masonry infilled frame with various types of masonry having various young modulus, using ABAQUS, and to be able to generalize with any type of masonry infill, we must take a model already established and check to be able to validate our calculations, so we took an example treated by [4], as shown in (Fig. 1).

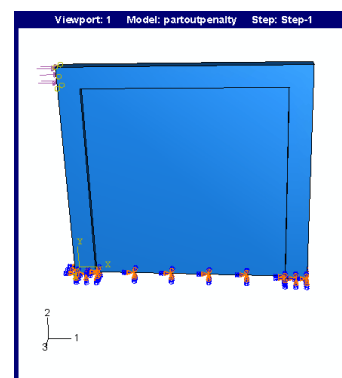

(a)

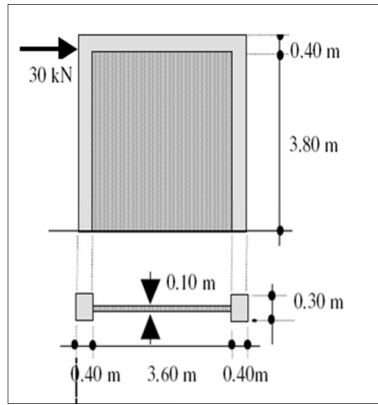

(b)

Fig. 1 (a) Model designed with Abaqus, (b) Model designed by Asteris [4]

*A. Size and Geometry of Model*

Size and geometry for various components of the numerical model are considered as proposed by the article taken; they are presented in Fig. 1 (a).

*B. Type of Element*

All the parts were modeled using C3D8R which refer to continuum three dimensional 8-noded brick element with reduced order integration [5]. This element has three degrees of freedom at each node, translations in the nodal x, y, & z. The solid (or continuum) elements in ABAQUS can be used for linear analysis and for complex nonlinear analyses involving contact, plasticity, and large deformations. Reduced integration reduces running time, especially in three dimensions.

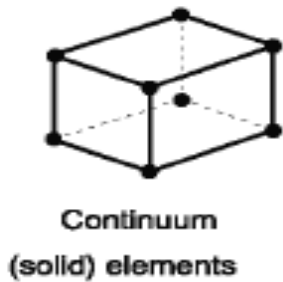

Fig. 2 Type of element used for modeling

*C. Material Properties*

The material properties for the various components of the numerical models are considered, as proposed by the article taken, the elasticity modulus of the concrete framework reinforced is 29000 MPa, and a Poisson's ratio is 0.20, and for masonry elasticity modulus in the normal direction with the joints is 7500 MPa, and a corresponding Poisson's ratio of 0.32.

*D.Mesh*

Meshes bricks and joints must be connected, this connection is difficult to manage when the bricks are deposited in a complex way including in the 3D case.

Fig. 3 show mesh density on Asteris model and that on ABAQUS

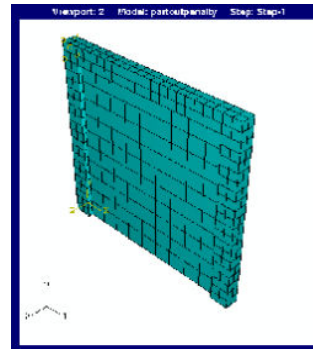

(a)

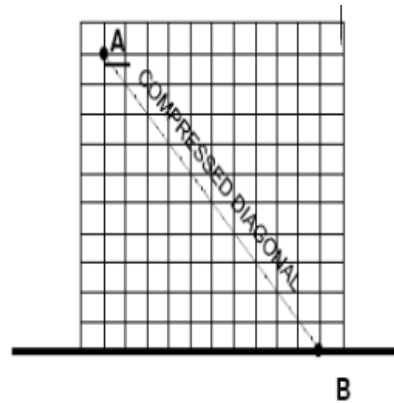

(b)

Fig. 3 (a) Mesh on Abaqus model, (b) Mesh on Asteris model

III. RESULTS DISCUSSION AND COMPARISONS

Figs. 4-6 show graphic results obtained from Asteris compared with that obtained from ABAQUS.

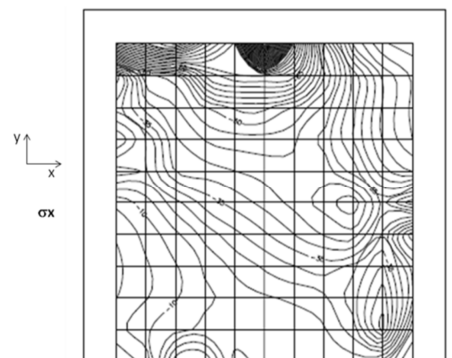

(a)

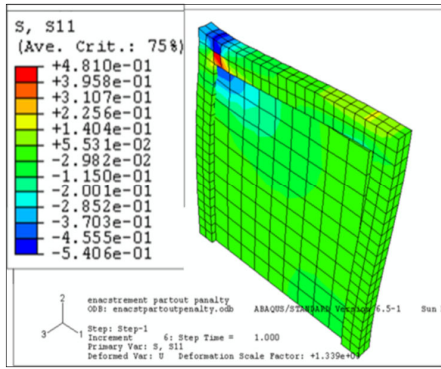

(b)

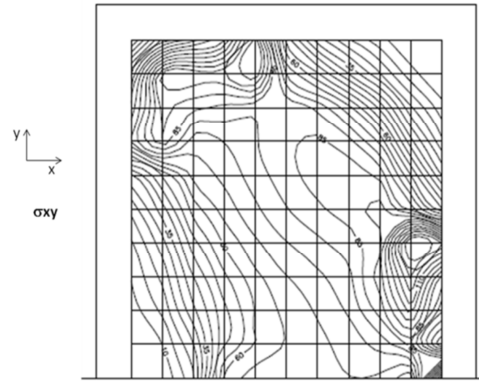

(a)

Fig. 4 Normal stresses in the parallel direction to the load (a) Model designed by Asteris, (b) Model designed with Abaqus

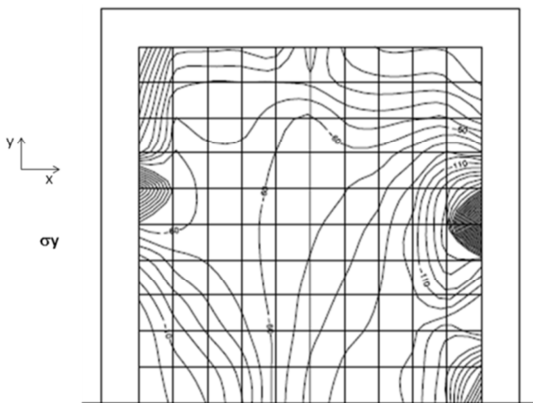

(a)

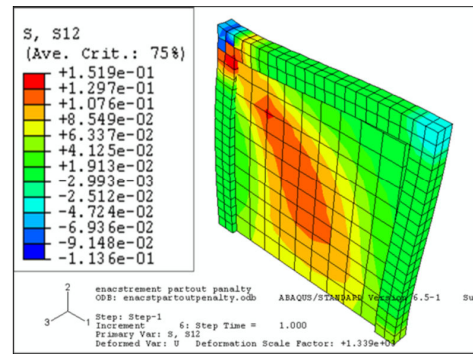

(b)

Fig. 6 Shear stresses (a) Model designed by Asteris, (b) Model designed with Abaqus

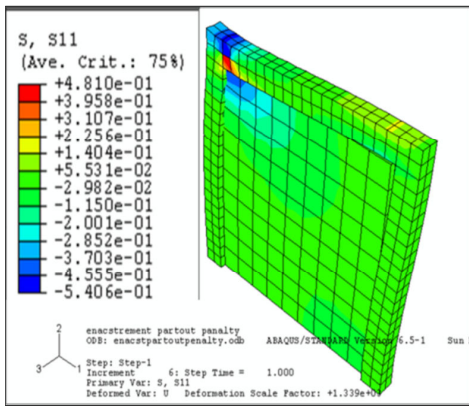

(b)

Fig. 5 Normal stresses in the normal direction to the load. (a) Model designed by Asteris, (b) Model designed with Abaqus

#### IV. CONTRIBUTION OF MASONRY INFILL WALLS IN STRUCTURES

We have developed simple models of structures with different properties of masonry infill, to know precisely their general behavior, using different ranges of homogenized elasticity modulus panels ranging from 750 to 20,000 MPa; increases in the relative rigidities of the structures according to the rigidity of masonry infill are shown in Fig. 7.

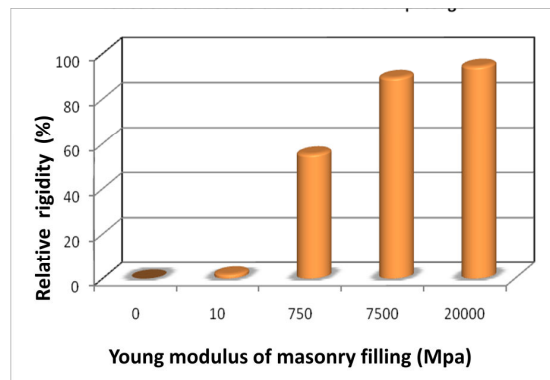
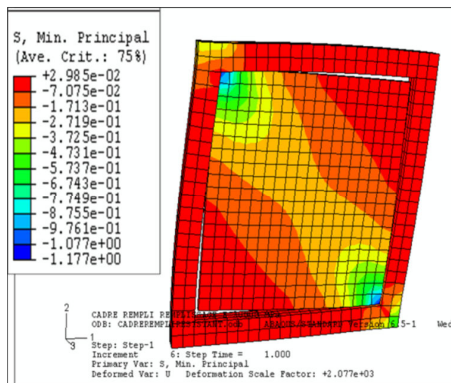

Fig. 7 Relative rigidity of the structures according to the Young modulus of masonry fillings

## V. FAILURE MODES

It is also observed that when the framework is subjected to horizontal loads, the framework separates from the filling on the level of the tended diagonal [6]-[8], as shown in Fig. 8, and the filling will be replaced in the structural analyses by an equivalent compressed diagonal of width "W". This theory was initiated by Stafford Smith [1], [9], [10].



(a)

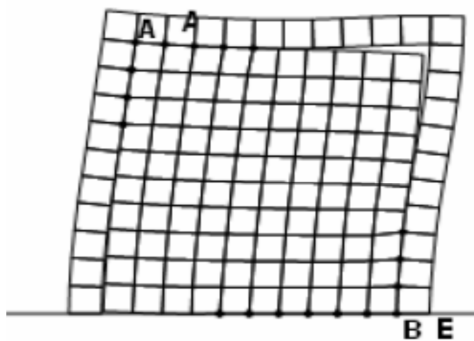

(b)

Fig. 8 Masonry filling separation observed (a) Model designed with Abaqus, (b) Model designed by Asteris

## VI. CONCLUSION

The principal aim of this work through a numerical study of the behavior of masonry infill walls in structures subjected to horizontal load is to propose by finite elements numerical modeling, a more reliable approach, faster and close to reality.

A finite element model was successfully constructed and developed using ABAQUS software. It is observed that more rigidity of the masonry filling is significant, more the structure is rigid, therefore the filling brings an additional rigidity to the structure not to be neglected. Moreover, when the framework is subjected to horizontal loads, the framework separates from the filling on the level of the tended diagonal, as shown in (Fig. 3), and the filling will be replaced in the structural analyses by an equivalent compressed diagonal of width "W".

## REFERENCES

- [1] Stafford Smith B «Behavior of square infilled frames» Journal of Structural Division, Proceedings of American Society of civil engineers, Vol 92 ST1, February (1966), pp 381-403.
- [2] KfouryA, «Contribution des éléments de remplissage à la rigidité latérale des cadre en acier» thèse de magistère de l'université de Montréal, Décembre (1985).
- [3] Yanev B. S, Niven Mc «Mathematical modeling of the seismic response of one story steel frames with infilled partitions» 3 Conf V2Mc Gill univ Montréal Qué Can Nat I Conf for earth eng, June (1979).
- [4] Asteris, P.G. (2008) "Finite Element Micro-Modeling of Infilled Frames", Electronic Journal of Structural Engineering N°8, 1-11.
- [5] ABAQUS 6.10," Analysis user manual".
- [6] M.Lafuente, C.genatios et M.lorrain «Etudes analytiques sur le comportement des murs en maçonnerie sous sollicitations latérales monotones » Materials and structures 1993 -26-PP 387,394.
- [7] Merzoud M, Habita M.F «Résistance à la compression diagonale des murs en maçonnerie» Colloque Maghrébin de Génie Civil, pp 151-157 CMGC (1999).
- [8] Stafford Smith, B. (1962) "Lateral stiffness on infilled frames", Proceedings of American Society of civil engineers, Vol 88 ST6, 182-197.
- [9] Yvener Gertin «Comportement sismique d'un mur en maçonnerie armée entièrement rempli de coulis» Mémoire de Maîtrise ès Sciences Appliquées Spécialité: génie civil Sherbrooke (Québec), CANADA Janvier 2014.
- [10] Grine.A «Comportement de la maçonnerie de la région de Annaba» Mémoire de Magister, Université Badji Mokhtar de Annaba, Mars (2002).