

OPEN_EmoRec_II- A Multimodal Corpus of Human-Computer Interaction

Stefanie Rukavina, Sascha Gruss, Steffen Walter, Holger Hoffmann, Harald C. Traue

Abstract—OPEN_EmoRec_II is an open multimodal corpus with experimentally induced emotions. In the first half of the experiment, emotions were induced with standardized picture material and in the second half during a human-computer interaction (HCI), realized with a wizard-of-oz design. The induced emotions are based on the dimensional theory of emotions (valence, arousal and dominance). These emotional sequences - recorded with multimodal data (facial reactions, speech, audio and physiological reactions) during a naturalistic-like HCI-environment one can improve classification methods on a multimodal level.

This database is the result of an HCI-experiment, for which 30 subjects in total agreed to a publication of their data including the video material for research purposes*. The now available open corpus contains sensory signal of: video, audio, physiology (SCL, respiration, BVP, EMG Corrugator supercilii, EMG Zygomaticus Major) and facial reactions annotations.

Keywords—Open multimodal emotion corpus, annotated labels.

I. INTRODUCTION

NOWADAYS, the progress of technological development is so fast and noticeable for almost every user. Especially technologies in public areas (e.g. ticket machine) but also complex IT softwares in work life with diminished usability can lead to frustration on the user's side.

To prevent these problems, newly called Companion Technology can help to overcome these problems. Such technology will have cognitive abilities and will be able to bridge the gap between usability and complex software manuals [1]. Furthermore, it is supposed to adapt to the user's abilities and experiences individually and above that to their emotions and dispositions [2]. Emotional and dispositional events in HCI are almost identical to events happening during human-human interactions [3]. This congruency makes it possible to use the same channels humans rely on to recognize emotions during the human-human interactions, such as speech and facial reactions. However, technological systems can additionally measure the user's psychobiological reactions in emotional or dispositional events. As they are continuously available and more difficult to control (like audio signal or facial reactions), they are often referred to as "honest signals" [4]. Most research groups assess physiological signals such as EMG, ECG, Respiration, Temperature and EEG. All of them have disadvantages concerning their availability, content of information, their recording method but also their reliability and validity [5]. Therefore the goal in affective computing is

to find a good ratio of recording emotional features and informational content. Finding a good combination of specific features extracted from multimodal data (after fusion of information) can improve classification accuracies of the emotional or dispositional events [6], [7].

II. OPEN_EMOREC_II

The OPEN_Emorec_II corpus was designed to induce emotional responses in HCI users during two different parts of a HCI-experiment, see Fig. 1. In the first half of the experiment, standardized picture material was used to induce emotions according to the dimensional model of emotions (see below). In the second half of the experiment the same dimensional emotions were induced during a naturalistic-like human-computer interaction in a standardized environment. It was realized as a wizard-of-oz experiment, which allows the user to have a "normal" interaction with different technological feedback, which is actually operated by a hidden human operator [8]. Different feedbacks dependent concerning the user's performance in various situations were systematically and repeatable [9] designed to induce different states of emotions [10].

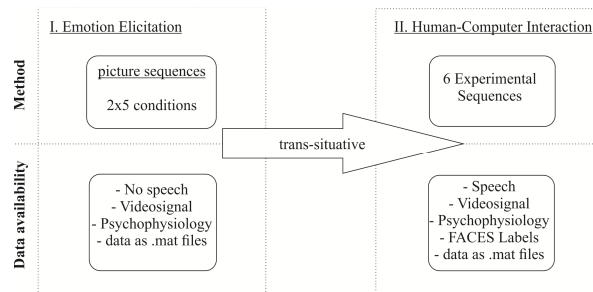

Fig. 1 OPEN_EmoRec_II

The OPEN_EmoRec_II corpus, can be made available to other research groups, enables the testing of different classification algorithms and the usage of different multimodal data, which was shown for a similar experiment [6], [7], [10]. In addition to the recording of data some of the mimical behavior is annotated, but it is still possible to perform specific annotations for the testing of hypothesis. For example, the combinations for using facial reactions as markers combined with audio signals, for example, have been shown to improve emotion classification rates [11] or the usage of solely physiological data after specific events [12] or audio data [13]. There are existing tools for annotating such approaches, like ATLAS [14], which has been applied to this corpus as well.

Stefanie Rukavina, Sascha Gruss, Steffen Walter, Holger Hoffmann, Harald C. Traue are with the department of Medical Psychology, Ulm University. (e-mail: stefanie.rukavina@uni-ulm.de).

OPEN_EmoRec_II was constructed in 2010-2011 on behalf of the SFB/TRR-62 and contains data of 30 subjects who agreed to the publication of their video material.

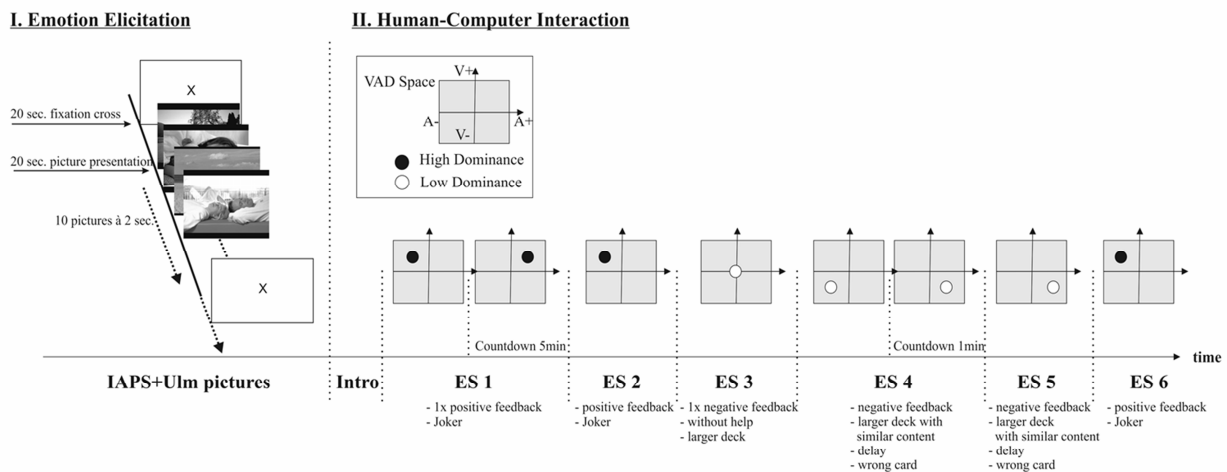

Fig. 2 Experimental Design

III. SETUP

For the realization of the wizard-of-oz Experiment it was necessary to split the setup in two rooms, one with the stimulus-PC for the subject (see Fig. 3) and one manipulation-PC for the wizard in another room. The picture presentation in the first half of the experiment was conducted in the same room.

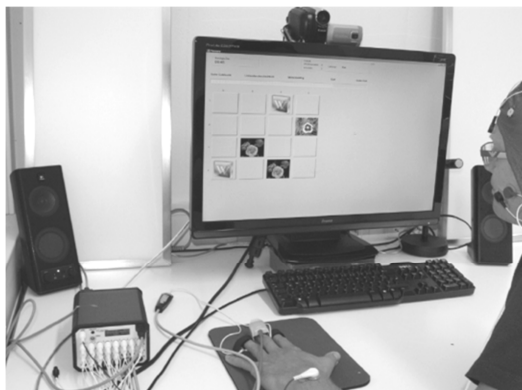

Fig. 3 Experimental Setup

The video and audio signal were recorded during the experimental HCI with a Canon, MD 125 camera attached to the screen. Via an extra microphone the conversation between the subject and the technical system (wizard) took place by Skype. The system feedback to the user was presented in natural language, recorded priorly, manipulated by the wizard, by loudspeakers during the whole experiment the physiological data recording utilized BiObserve software and a Nexus-32 (24-bit; MindMedia, NL) with a sampling rate of 512 Hz. The software BiObserve managed the synchronicity

between physiology, audio and video signal as well as the trigger information.

In total, we recorded during both experimental procedures: video, audio, trigger information and physiological data: respiration, EMG corrugator supercillii, EMG zygomaticus major, BVP and Skin Conductance (SCL).

IV. EXPERIMENTAL DESIGN

A. General Information

The experimental design, based on a previous experiment EmoRec I [10] was refined in a way, that there was a prolonged emotion stimulation in the first part and only one round in total in the wizard-of-oz experiment, see Fig. 2. During both experimental parts, emotions were induced in a dimensional manner, according to their ratings in the dimensions of valence, arousal and dominance [15], [16].

Although we will not forstall the use of this database, we would recommend one possibility, namely the testing of trans-situative classification of emotions. This means, the first part of the experiment can be used for the training of the classifiers whereas the second part can be used to test the classifiers. This can be recommended because the emotional responses have been induced by different situations within the same model.

B. Emotion Elicitation with Standardized Picture Material

For the emotion elicitation pictures from the IAPS and a completing Ulm picture set were used [17], [16]. To intensify the emotion induction a prolonged presentation was used [18], [19]. One stimulus sequence consisted of 10 pictures with similar ratings according to the five possible affective states: high valence and high arousal (HVHA), high valence and low arousal (HVLA), low valence and low arousal (LVLA), low valence and high arousal (LVHA) and neutral. Each picture in

a stimulus sequence was displayed for 2 sec without a pause between the following pictures. After each stimulus sequence a fixation cross was presented for neutralization of the user's affective state.

In total, 10 stimulus sequences (two for each of the 5 affective states) were presented which leads to 100 pictures used. The order of pictures in each stimulus sequence was fixed, but the presentation of the 10 stimulus sequences was randomized. Further trigger information and picture ratings are attached in the Appendix.

C. Human-Computer Interaction

The second part of the experiment was the simulation of a naturalistic-like human-computer interaction in a wizard-of-oz design.

This part of the HCI-experiment was designed to allow the subject to interact as natural as possible with the technical system via natural speech. The subjects were instructed to try to make minor mistakes in a memory task and be as fast as possible. With these two instructions the subjects got motivated and were eager to win the challenge.

The task was to solve 6 experimental sequences (ES) of a mental trainer which followed the principle of the popular game 'concentration'. Each ES was designed to induce different emotions within the affect grid by using different technical feedback, see Fig. 2. Although the protocol was strict about which technical feedback was allowed to use in each ES, the wizard (a psychologically skilled operator) could adapt the protocol to individual needs, e.g. if the emotional induction had to be increased. A detailed description of each ES can be found in [10] for further information. The technical feedback was verbal and of a natural spoken language by a professional male speaker.

After a short instruction by the technical system itself the experimental sequences started with ES 1. ES 1 was to increase valence with the help of Jokers (if the subject opened the wrong cards) and positive feedback concerning the subject's performance to 'good'. At the end of ES 1 a 5 minute countdown timer was set to increase the arousal.

ES 2 was to increase valence further to 'very good' but with less arousal. Therefore no time limit was given. ES 3 was about to induce a neutral emotional state. Therefore, the subject's performance was rated as "medium" and no technical feedback was given.

ES 4 and ES 5 were about to induce a negative state. Therefore in both rounds the amount of cards was increased and the motives were similar and hard to discriminate, which makes it more difficult to remember the 'right' motive. In ES 4 the subject's performance was rated as 'low', the game was manipulated e.g. a false card was displayed or with a delay. After the half of this round, there was a one-minute timer to increase arousal. ES 5 was about to decrease valence further, therefore more negative feedback was used in combination with repeatedly asked question 'if the user would like so, than the technical system will cancel this round because it is too difficult'.

The final ES 6 was used to induce a positive state again.

With the help of Jokers the wizard manipulated this round to improve the subject's performance so it could be rated as 'very good'.

At the end of the experiment, the subjects were asked to rate each ES with the use of the SAM Rating. This rating can be used as a manipulation check.

V. DATA RECORDING

A. General Information

This OPEN_EmoRec_II database consists only of 30 subjects of a total of xx subjects because only the Ss agreed with public scientific use of the material. However, due to technical problems within the recording, there is no trigger information for one subject during part I and there are 3 videos missing for 3 subjects during part I.

The main focus of this database is the classification of physiological signals during part II, therefore this data had a higher priority.

B. Physiological Signals

During this experiment an EEG (Electroencephalogram) was also recorded, however the signal was excluded from the analysis and also from the database due to technical problems which caused many quality problems.

The physiological channels in this data set will be described in the following section: The sensors BVP and SCL were attached to the non-dominant hand which was the left hand for each subject.

Blood volume pulse (BVP): The BVP sensor measured indirectly the heart rate. The underlying technique of this sensor 'Photoplethysmography' sends infrared light with a specific wave length (990nm) and measures the reflected amount of light. The rest of the light will be absorbed by the hemoglobin in the blood. With this measurement you can indirectly calculate the heart rate with alternating vasodilatation and vasoconstrictions. This signal correlates highly with the heart rate measured via ECG [20]. A finger clip was attached to the left middle finger, see Fig. 1.

Skin Conductance Level (SCL): The electrodermal activity is a robust measurement of the sympathetic branch of the ANS (autonomous nerve system) and can easily be detected with two sensors measuring the current between their sites (index and ring finger of the left hand). Since it is solely sympathetic innervated it is a good indicator for arousal with phasic responses and slow tonic components [21].

Electromyogram (EMG): The surface EMG is a sum potential of all muscle fibers under the electrodes and a reliable measure of muscle activity. In emotion research two muscle sites of typical EMG recordings have been established: Corrugator supercillii (frowning muscle) and Zygomaticus major (smiling muscle). Both muscles are shown to discriminate valence very well [5].

Respiration (RSP): Respiration was recorded via a strain sensitive belt attached to the chest. Using this measurement it is able to measure respiration frequency and the depth of each exhalation and inhalation. Respiration has an influence on

other physiological signals, e.g. respiratory sinus arrhythmia of the heartbeat.

C. Subjects

This database consists of 30 right handed subjects (n=23 women; mean age: 37.5 years; n=7 men; mean age: 51.1 years). Every subject signed the informed consent and allowed thereby the publication of their video-, audio-, and physiological signals. After participation every subject earned 35€. The study was conducted according to the ethical guidelines of Helsinki (certified by the Ulm University ethics committee: C4 245/08-UBB/se).

D. Manipulation Check

For the emotion induction via standardized picture material there was no extra rating essential.

After the HCI experiment the subjects were asked to rate each ES with the dimensional scale of the SAM rating according to valence, arousal and dominance [22], see Table I.

The ratings show, that it was possible to induce positive emotions with high valence in ES 1, ES 2 und ES 6. Although ES 3 should induce a neutral condition, valence rating show here higher values than expected. ES 4 and ES 5 induced negative emotions as it was hypothesized.

TABLE I
SAM RATING OF THE EXPERIMENTAL SEQUENCES

Rating	ES 1	ES 2	ES 3	ES 4	ES 5	ES 6
Valence	7,96	6,96	6,96	5,63	4,12	8,54
Arousal	3,55	4,29	4,67	5,11	6,15	3,52
Dominance	7,70	7,25	6,66	6,03	4,80	8,08

SAM Rating of the 30 subjects for OPEN_EmoRec_II

E. Synchronicity

For multimodal databases the synchronicity between physiology and video/audio signals is crucial. Therefore, all incorporated data in this corpus were controlled for synchronicity manually in addition to the software triggering. This was done by checking the movements of an eye blink in the video with the corresponding muscle activity pattern within the Corrugator EMG. In case of an offset, this was corrected by time shifting of the data line.

VI. FACIAL EXPRESSION ANNOTATION

To provide the database with further label information about the subjects' emotional behavior, the facial reactions to the technical feedback during part II was labeled according to the FACES guidelines [23]. With this method, the facial expression was labeled according to valence (positive, negative) and intensity (1-4 Likert scale), which is useful as it is identical to the dimensional approach like the whole emotion induction. Every one of the 4 raters also included the information of how expressive the subject was in total (1-5 Likert scale) and the start and end time of the emotional expression from which the duration could be calculated. The ICC(3,4) model (intraclass correlation coefficient, two-way randomized) was used to calculate the agreement between the

4 raters according to [24] leading to ICC= 0.74. This value is the mean of the ICC for valence = 0.75, ICC for intensity = 0.65, ICC for duration =0.70 and ICC for expressiveness = 0.84. It can be seen, that the 4 raters had a relatively high agreement on their ratings.

The facial reactions were labeled after a positive/negative feedback or a system-corresponding (delay, wrong card) feedback. All the verbal technical feedbacks were short with a mean of 2.1 sec. The delay-system feedback took 6 sec, which is why the labeled videos were 6 sec long.

TABLE II
FACES LABEL CLASS

Label Class	n	description
VN_1,0*	78	4 raters detected expression and agreed in valence
VP_1,0*	41	4 raters detected expression and agreed in valence
VN_0,75	97	3 rates detected expression and agreed in valence
VP_0,75	26	3 rates detected expression and agreed in valence
VN_0,5	167	2 raters detected expression and agreed in valence
VP_0,5	44	2 raters detected expression and agreed in valence
VA_0,4	102	4 raters detected expression; 2 agreed in positive and 2 in negative
VA_0,3	116	3 raters detected expression; 2 agreed in valence
VA_0,2	86	2 raters detected expression; 1 agreed in positive and 1 in negative

VN=valence negative; VP=valence positive; VA= valence ambivalent; Due to the fact that the raters were not sure about the valence in some expressions the label "ambivalent" was added. This is optional and can be excluded if wished

For the conclusion of all the detected emotional expressions of each subject, it was important that at least 2 raters have seen and rated the expression, otherwise the event was not taken into account. If there was an agreement, the event would be labeled according to its valence and to the amount of raters (see Table II).

Finally, it is possible to integrate the facial reactions into the database like second trigger information. Since in most cases the subjective starting point of a facial expression was different for each of the raters, there is also the standard deviation for every variable (start, end, apex).

Further information is available in the appendix.

VII. CONCLUSIONS

With OPEN_EmoRec_II it is possible to analyze user behavior during emotion induction with standardized picture material and during a speech based naturalistic communication with a computer system. Especially with the help of the facial annotation one may see, that users react emotionally when being evaluated according to their performance. It has often been criticized, that emotional behavior doesn't occur often and are rare [25]. Of course, these emotional events may be less intensive towards a computer, but they react visibly for other humans.

Therefore it is crucial to make affective computers more sensitive and specialized individually to their users, which will have impact on the classification methods [26].

VIII. APPENDICES

TABLE III
TRIGGER INFORMATION FOR EMOTION ELICITATION WITH PICTURE MATERIAL PART I

Trigger	Affective Core	Slide	Valence	Arousal	Dominance
video 1	neutral	7050	4,93	2,75	5,82
		7043	5,17	3,68	6,38
		7041	4,99	2,60	6,35
		7004	5,04	2,00	6,74
		7059	4,93	2,73	6,22
		7211	4,81	4,20	4,99
		7080	5,27	2,32	7,04
		7052	5,33	3,01	6,19
		7175	4,87	1,72	6,47
		7056	5,07	3,07	6,38
video 2	HVHA	8400	7,09	6,61	4,63
		1650	6,65	6,23	4,29
		5470	7,35	6,02	4,96
		8180	7,12	6,59	4,97
		8341	6,25	6,40	4,66
		5700	7,61	5,68	4,59
		5950	5,99	6,79	3,56
		RM*	5,83	7,31	4,40
		8191	6,07	6,19	4,88
		8030	7,33	7,35	4,70
video 3	LVHA	3500	2,21	6,99	2,4
		3120	1,56	6,84	3,32
		3053	1,31	6,91	2,33
		9921	2,04	6,52	3,57
		9810	2,09	6,62	3,95
		3170	1,46	7,21	2,7
		9926	3,85	4,83	4,37
		3000	1,59	7,34	2,73
		6300	2,59	6,61	2,78
		9920	2,5	5,76	3,09
video 4	HVLA	5551	7,31	3,26	6,48
		2360	7,7	3,66	6,92
		2388	7,44	3,77	6,62
		5200	7,36	3,2	6,21
		1610	7,82	3,08	6,77
		5779	7,33	3,57	6,96
		2037	6,42	3,35	6,21
		2540	7,63	3,97	5,96
		5760	8,05	3,22	7,49
		1620	7,37	3,54	6,82
video 5	LVLA	6010	3,73	3,95	5,08
		9045	3,75	3,89	5,03
		2722	3,47	3,52	5,34
		2715	3,28	4,35	5,17
		9101	3,62	4,02	5,35
		8010	4,38	4,12	5,17
		7046	4,18	4,14	5,22
		2280	4,22	3,77	5,7
		2210	4,38	3,56	5,03
		7700	4,25	2,95	5,13

TABLE IV
TRIGGER INFORMATION FOR EMOTION ELICITATION WITH PICTURE MATERIAL PART II

Trigger	Affective Core	Slide	Valence	Arousal	Dominance
video 6	neutral	7006	4,88	2,33	6,18
		7150	4,72	2,61	5,55
		7010	4,94	1,76	6,70
		7009	4,93	3,01	6,33
		7161	4,98	2,98	5,68
		7000	5,00	2,42	6,14
		6150	5,08	3,22	5,54
		7110	4,55	2,27	6,07
		7035	4,98	2,66	6,39
		7025	4,63	2,71	6,1
video 7	HVHA	4695	6,84	6,61	5,95
		5621	7,57	6,99	5,81
		8080	7,73	6,65	5,91
		8370	7,77	6,73	5,37
		5629	7,03	6,55	5,68
		4611	6,62	6,04	5,99
		8490	7,20	6,68	5,37
		8503	7,02	5,22	6,33
		8161	6,71	6,09	5,89
		4690	6,83	6,06	6,12
video 8	HVLA	LO7*	7,01	2,67	7,15
		LO1*	7,73	3,01	7,36
		LO2*	8,11	3,11	7,40
		LO6*	6,41	2,31	7,24
		LO3*	7,88	3,21	7,3
		LO8*	7,89	2,93	7,45
		LO5*	7,86	3,35	7,17
		LO9*	7,52	2,77	7,14
		LO4*	7,69	2,89	7,04
		LO *	7,79	2,73	7,30
video 9	LVLA	LU1*	3,32	3,49	5,50
		LU6*	4,10	3,04	5,93
		9360	4,03	2,63	5,34
		LU5*	3,01	3,40	5,58
		LU8*	3,75	3,71	5,72
		9390	3,67	4,14	5,22
		LU9*	3,43	3,79	5,42
		LU *	3,83	3,12	5,75
		LU7*	2,99	4,22	5,18
		LU2*	3,38	3,62	5,28
video 10	LVHA	5971	3,49	6,65	3,30
		9250	2,57	6,60	3,73
		3400	2,35	6,91	3,65
		2800	1,78	5,49	3,40
		9410	1,51	7,07	2,81
		9424	2,87	5,78	3,78
		6230	2,37	7,35	2,15
		3266	1,56	6,79	2,83
		6350	1,90	7,29	2,73
		1050	3,46	6,87	3,08

*Ulm pictures

ACKNOWLEDGMENT

This research was supported in part by grants from the Transregional Collaborative Research Centre SFB/TRR 62 "Companion-Technology for Cognitive Technical Systems" funded by the German Research Foundation (DFG). We also

would like to thank Sascha Meudt for supporting the annotation with the annotation tool ATLAS and Felix Schüssel for further support with the videos. Last but not least we would like to thank Nike Schier, Gerrit Blum and Kristina Wolniak for helpful discussions and labeling the facial

expressions.

AVAILABILITY

OPEN_EmoRec_II is available for research groups. Please feel free to visit www.emotionlab.org and contact stefanie.rukavina@uni-ulm.de or harald.traue@uni-ulm.de for comments or questions.

REFERENCES

- [1] Wendemuth, A. and S. Biundo, A Companion Technology for Cognitive Technical Systems, in COST 2102 International Training School, A. Esposito, et al., Editors. 2012, LNCS 7403, Berlin, Springer: Dresden, Germany. p. 89-103.
- [2] Traue, H.C., et al., A Framework for Emotions and Dispositions in Man-Companion Interaction, in Converbal Synchrony in Human-Machine Interaction, M. Rojc and N. Campbell, Editors. 2013, CRC Press. p. 98-140.
- [3] Walter, S., et al., "Similarities and differences of emotions in human-machine and human-human interactions: what kind of emotions are relevant for future companion systems?". *Ergonomics*, 2014. 57(3): p. 374-86.
- [4] Pentland, A.S., *Honest Signals: How they shape our world*. 2008, Cambridge, Massachusetts, London, England: MIT Press.
- [5] Tan, J., et al., "Repeatability of facial electromyography (EMG) activity over corrugator supercilii and zygomaticus major on differentiating various emotions". *J Ambient Intell Human Comput*, 2012. 3(3): p. 3-10.
- [6] Schels M, et al. Multi-Modal Classifier-Fusion for the Classification of Emotional States in WOZ Scenarios. in 1st International Conference on Affective and Pleasurable Design (APD'12) 2012: CRC Press.
- [7] Böck, R., et al. Intraindividual and interindividual multimodal emotion analyses in human-machine-interaction. in *Cognitive Methods in Situation Awareness and Decision Support (CogSIMA)*, 2012 IEEE International Multi-Disciplinary Conference on. 2012: IEEE.
- [8] Bernsen, N.O., H. Dybkjaer, and L. Dybkjaer, Wizard of oz prototyping: When and How, in *Experimentelle Emotionspsychologie*, W. Janke, M. Schmidt-Daffy, and G. Debus, Editors. 2008, Pabst Publishers: Lengerich. p. 179-192.
- [9] Kächele, M., S. Rukavina, and F. Schwenker. Paradigms for the Construction and Annotation of Emotional Corpora for Real-World Human-Computer-Interaction. in *International Conference on Pattern Recognition Applications and Methods (ICPRAM)*. 2015: SciTePress.
- [10] Walter, S., et al., "Transsituational Individual-Specific Biopsychological Classification of Emotions". *Systems, Man, and Cybernetics: Systems*, IEEE Transactions on, 2013. 43(4): p. 988-995.
- [11] Limbrecht-Ecklundt, K., et al., The importance of subtle facial expressions for emotion classification in human-computer interaction, in *Emotional Expression: The Brain and The Face*, F.-M. A, Editor. 2013, UFT Press.
- [12] Hrabal, D., et al., Physiological Effects of Delayed System Response Time on Skin Conductance, in *Multimodal Pattern Recognition of Social Signals in Human-Computer-Interaction*, F. Schwenker, S. Scherer, and L.-P. Morency, Editors. 2013, Springer Berlin Heidelberg. p. 52-62.
- [13] Scherer, S., et al., "Spotting laughter in natural multiparty conversations: A comparison of automatic online and offline approaches using audiovisual data". *ACM Trans. Interact. Intell. Syst.*, 2012. 2(1): p. 1-31.
- [14] Meudt, S., L. Bigalke, and F. Schwenker. ATLAS – an annotation tool for HCI data utilizing machine learning methods. in 1st International Conference on Affective and Pleasurable Design (Jointly with the 4th International Conference on Applied Human Factors and Ergonomics (AHFE'12)), 2012.
- [15] Lang, P.J., M.M. Bradley, and B.N. Cuthbert, *International Affective Picture System (IAPS): Affective ratings of pictures and instruction manual*. Technical Report A-6. 2005, University of Florida, Gainesville, FL.
- [16] Lang, P.J., M.M. Bradley, and B.N. Cuthbert, *International affective picture system (IAPS): Technical manual and affective ratings*. 1999, University of Florida, Center for Research in Psychophysiology: Gainesville.
- [17] Walter, S., et al., "The influence of neuroticism and psychological symptoms on the assessment of images in three-dimensional emotion space". *Psychosoc Med*, 2011. 8: p. Doc04.
- [18] Smith, J.C., M.M. Bradley, and P.J. Lang, "State anxiety and affective physiology: effects of sustained exposure to affective pictures". *Biological Psychology*, 2005. 69(3): p. 247-60.
- [19] Valenza, G., A. Lanata, and E.P. Scilingo, "The Role of Nonlinear Dynamics in Affective Valence and Arousal Recognition". *IEEE Transactions on Affective Computing*, 2011 PrePrints. 99.
- [20] Selvaraj, N., A. Jaryal, J. Santhosh, K.K. Deepak, and S. Anand, "Assessment of heart rate variability derived from finger-tip photoplethysmography as compared to electrocardiography". *Journal of Medical Engineering & Technology*, 2008. 32(6): p. 479-484.
- [21] Benedek, M. and C. Kaernbach, "Decomposition of skin conductance data by means of nonnegative deconvolution". *Psychophysiology*, 2010. 47(4): p. 647-58.
- [22] Bradley, M.M. and P.J. Lang, "Measuring emotion: the Self-Assessment Manikin and the Semantic Differential". *Journal of Behavior Therapy and Experimental Psychiatry*, 1994. 25(1): p. 49-59.
- [23] Kring, A. and D. Sloan, "The Facial Expression Coding System (FACES): Development, validation, and utility.". *Psychological Assessment*, 2007. 19(2): p. 210-224.
- [24] Hallgren, K.A., "Computing Inter-Rater Reliability for Observational Data: An Overview and Tutorial". *Tutorials in quantitative methods for psychology*, 2012. 8(1): p. 23-34.