

Compensation of Power Quality Disturbances Using DVR

R. Rezaeipour

Abstract—One of the key aspects of power quality improvement in power system is the mitigation of voltage sags/swells and flicker. Custom power devices have been known as the best tools for voltage disturbances mitigation as well as reactive power compensation. Dynamic Voltage Restorer (DVR) which is the most efficient and effective modern custom power device can provide the most commercial solution to solve several problems of power quality in distribution networks. This paper deals with analysis and simulation technique of DVR based on instantaneous power theory which is a quick control to detect signals. The main purpose of this work is to remove three important disturbances including voltage sags/swells and flicker. Simulation of the proposed method was carried out on two sample systems by using Matlab software environment and the results of simulation show that the proposed method is able to provide desirable power quality in the presence of wide range of disturbances.

Keywords—DVR, Power quality, Voltage sags, Voltage swells, Flicker.

I. INTRODUCTION

OVER the past five decades, the increased use of sensitive electronic circuits by industries and households together with privatization and competition in electric power systems, non-linear loads and the power system faults cause some disturbances in a power system. Power quality is one of the major concerns due to its impact on electricity equipment and it is described as a variation of voltage and current [1], [2]. The problem of harmonics, voltage sags/ swells and flicker and their major impact on sensitive loads are well known in the power distribution system [3], [4].

Considering the high speed of response and flexibility of electronic devices for power quality improvement, custom power devices are seriously noticed to solve the power quality problems. One of those devices is the Dynamic Voltage Restorer (DVR), which is one of the most efficient and effective modern custom power devices used in power distribution networks [5]-[8]. Various methods have been used for controlling DVR [9], [10] in order to solve several problems of power quality including dq0 algorithm [11], three dimensional voltage space vector PWM algorithm [12], using repetitive controllers [13], optimum energy consumption strategy [14] and many other creative methods [15]-[18]. However, there is complexity of calculations in classic methods or low quality of response is observed in some

methods of frequency domain. The main objective of this paper is to introduce a quick signal detecting strategy based on instantaneous power theory with the aim of assuring certain detecting accuracy for controlling signal of DVR. The suggested strategy which is a time has high speed and response besides the capability of solving voltage quality disturbances.

The other parts of this paper include the following parts: the structure of DVR is studied in detail in Part II. The suggested control method is explained in Part III and the result of simulation are presented in Part IV in order to remove voltage sags/swells and flicker. The conclusion is offered in Part V.

II. STRUCTURE OF DVR

DVR employs a series of voltage boost technology using solid state switches for compensating voltage disturbances. The basic configuration of DVR has been shown in Fig. 1 [19]. Principally the structure of DVR includes an injection/booster transformer, a harmonic filter, storage devices, a voltage source converter (vsc), DC charging circuit and a control system. It is normally installed between the supply and the critical load feeder at the point of common coupling (pcc). DVR with the unique capability for series compensation employs voltage sourced converters linked at the same DC terminal.

Control unit is the heart of DVR where its main function is to detect the presence of voltage sags/swells and flicker in the system, calculate the required compensating voltage for the DVR and generate the reference voltage for PWM generator to trigger on the PWM inverter.

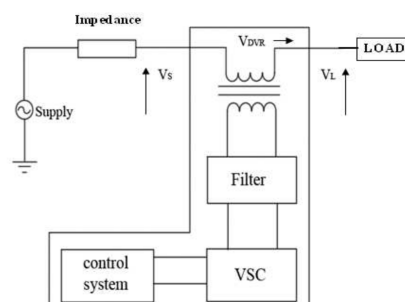

Fig. 1 General structure of a DVR

III. PRESENTATION OF CONTROL METHOD

Use the control method suggested in this part includes series control part, which is based on instantaneous direct detecting method of controlling signal. Ideal compensating

R. Rezaeipour is assistant professor with the Department of Electrical Engineering, College of Technical and Engineering, Tabriz Branch, Islamic Azad University, Tabriz, Iran (phone: +98 413 3309720; fax: +98 4133280055; e-mail: r.a.rezaei@gmail.com).

results are that load voltage is standard positive-sequence sine voltage of principle wave and power source only supply pure active power positive-sequence sine current of principle. So the control signal applied on DVR should be in a way that we can obtain complete sinusoidal voltage in load side, through applying it in series with non-sinusoidal and unbalanced source. For this purpose it is necessary to obtain reference signal which the complete corrected sinusoidal voltage should be in its form. Powers are calculated directly from the a-b-c phase voltages. It eliminates the need for complicated $\alpha\beta$ coordinate transformation, thus reducing the computation volume and improving the detection speed. However, this method requires low pass filter.

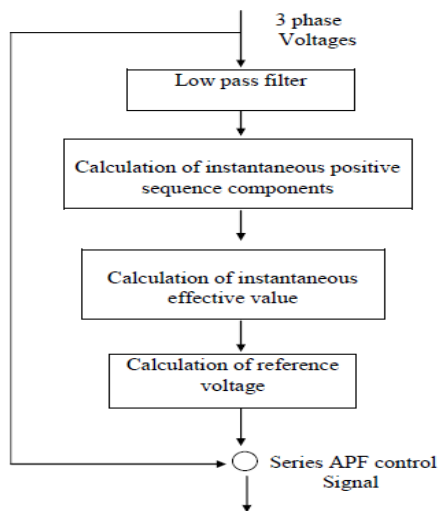

Fig. 2 DVR control diagram

This method does not require calculation of voltage component and in this way a delay in compensator response is avoided. The development stages of signal for DVR control are shown in diagram Fig. 2. If the voltage signals of u_a , u_b and u_c are three-phase voltages include distortion, they will only have fundamental frequency component after passing the low pass filter. Now using (1), the components of their instantaneous positive sequence, those are u_a^+ , u_b^+ and u_c^+ will be calculated:

$$\begin{bmatrix} u_a^+ \\ u_b^+ \\ u_c^+ \end{bmatrix} = \frac{1}{3} \begin{bmatrix} 1 & -0.5 & -0.5 \\ -0.5 & 1 & -0.5 \\ -0.5 & -0.5 & 1 \end{bmatrix} \begin{bmatrix} u_a \\ u_b \\ u_c \end{bmatrix} + \frac{\sqrt{3}}{6\omega} \begin{bmatrix} 0 & D & -D \\ -D & 0 & D \\ D & -D & 0 \end{bmatrix} \begin{bmatrix} u_a \\ u_b \\ u_c \end{bmatrix} \quad (1)$$

where D is the derivative operator.

Then, the effective value of positive sequence voltage is determined through (2) as instantaneously

$$U = \left(\sqrt{\text{abs} \left(\frac{1}{T} \int_i^{T+i} (u^+)^2 \right)} \right) \quad (2)$$

Now the wave form of the main components of distorted voltage which for phase α is as (3) can be accessed

$$u_a^+ = \sqrt{2}U \sin(\omega t + \alpha) \quad (3)$$

where, I_F is the fault current. Be sure that the border is off.

$$v_a = \frac{V}{U} u_a^+ = \sqrt{2}V \sin(\omega t + \alpha) \quad (4)$$

where V is the effective value of desirable voltage. Finally, the control signal of series active filter is obtained through comparing the reference signal obtained from (4) and distorted signal.

IV. SIMULATION RESULTS

In this section, the simulation study was performed using SIMULINK software in MATLAB environment for voltage quality problems in order to study the performance of suggested method.

A. Existence of Voltage Sags

The system being studied in this state is a 400V three phase network including a 10KW power constant linear load.

The study was performed from $t=0.1s$ to $t=0.2s$. Figs. 3 (a)-(c) show voltage sags in voltage of source, compensating voltage of DVR and well corrected load voltage, respectively.

As it is seen in Fig. 3 (c) the load voltage is completely corrected after $t=0.1s$ which DVR is activated. Also as it is seen there is a short transient in correction around one power cycle due to time needed for exact amount computation by RMS block calculator.

B. Existence of Voltage Swells

In this state, a 400 V network with $R=0.01\Omega$ and $L=1mH$ is considered as a generator. This system feeds a linear load which is a three phase balance 10 KW constant power load. The study was performed for 0.2 second time interval and DVR is considered to operate at $t=0.1s$. Fig. 4 (a) shows high level voltage sags and the Fig. 4 (c) shows that after operation of DVR, voltage is reduced to its desirable value.

C. Existence of Voltage flicker

The system being studied in this state is a 400V three-phase network including a 10 kW power constant linear load with the $\pm 20\%$ magnitude fluctuations and 8Hz frequency. The Study was performed from $t=0.1s$ to $t=0.4s$. It has been assumed that the voltage of source increase in order to improve the effective value of voltage after removing flicker at $t=0.4s$. Figs. 5 (a)-(c) show flicker in voltage of source, compensating voltage of DVR and well-corrected load voltage, respectively. To show the ability of proposed method in flicker reduction, the RMS value of load voltage and source voltage are illustrated in Fig. 5 (d). It shows that after operation of DVR, the RMS voltage is reduced to its desirable value after passing a short transient.

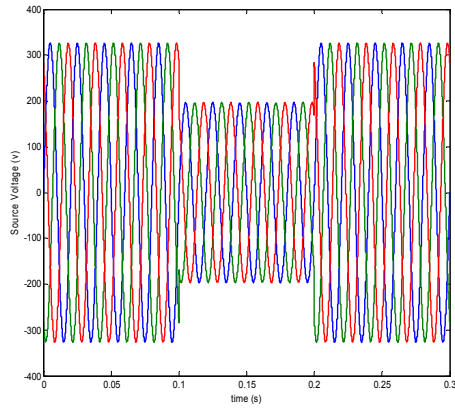

Fig. 3 (a) Source voltage

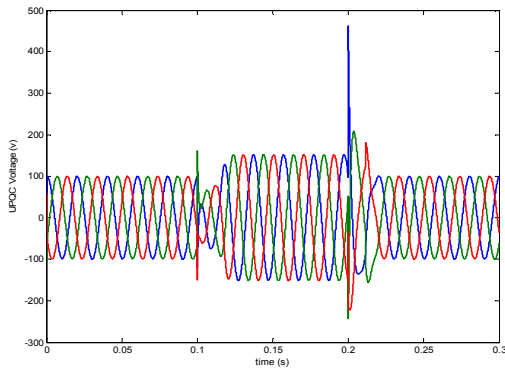

Fig. 3 (b) DVR voltage

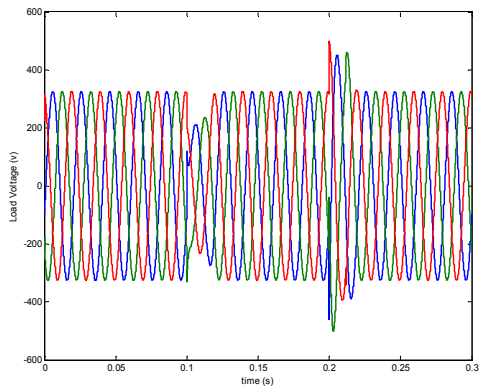

Fig. 3 (c) Corrected voltage at load side

V. CONCLUSIONS

Direct signal detection method for DVR control is proposed in this paper. The suggested method based on calculation of reference signal in time domain is very simple and fast without any complexity of calculations. By the way, this method can satisfy the requirement when considering both dynamic real-time tracking speed and compensating accuracy. This novel strategy acts based on the conditions of network in any time, regarding to remove voltage quality disturbances from the distribution system. The proposed control method corrects the load voltage to a perfect sinusoidal form with

exact RMS value. Other than voltage sags/swells and flicker compensation, DVR can added other features like line voltage harmonics compensation, reduction of transients in voltage and fault current limitations. Computer simulation was performed using Simulink on two typical case studies. One system is with the voltage sags/swells and the other with flicker. The results show that the suggested method managed to remove the disturbances in all cases.

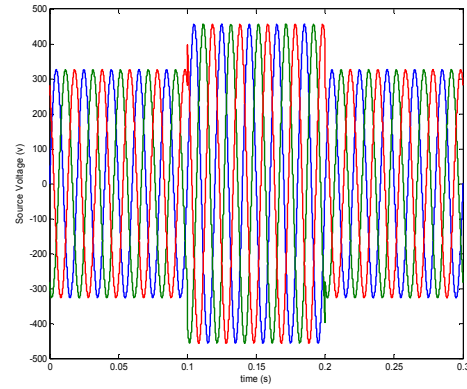

Fig. 4 (a) Source voltage

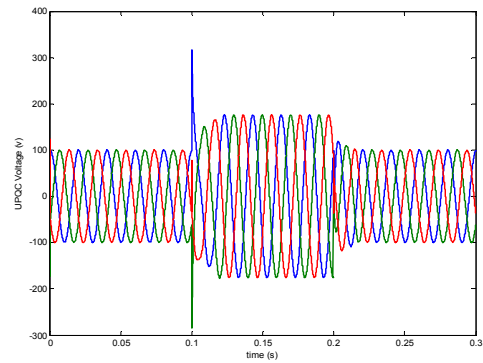

Fig. 4 (b) DVR voltage

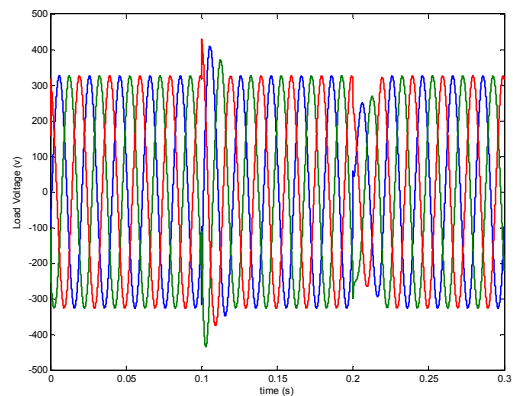

Fig. 4 (c) Corrected voltage at load side

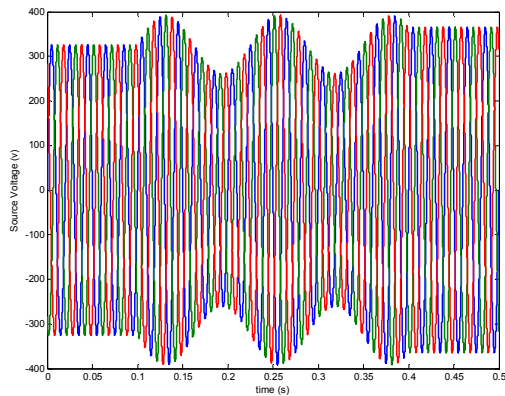

Fig. 5 (a) Source voltage

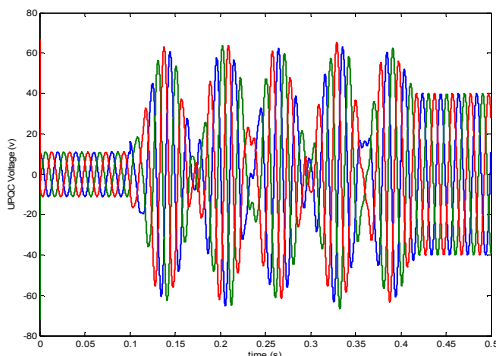

Fig. 5 (b) DVR voltage

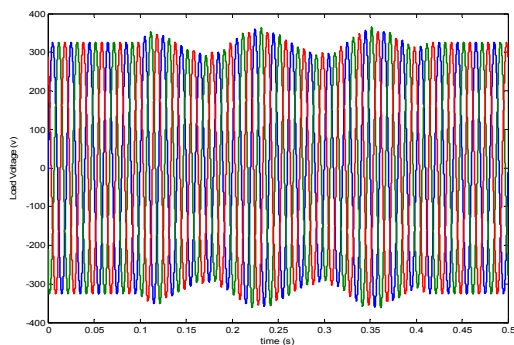

Fig. 5 (c) Corrected voltage at load side

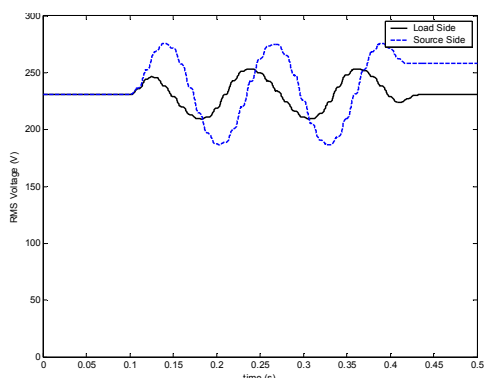

Fig. 5 (d) Effective values of source and load voltages

APPENDIX

The study was performed from $t=0.1s$ to $t=0.2s$ for both voltage sags and voltage swells and the magnitude of disturbances have been considered +40% and -40% for voltage swells and voltage sags ,respectively.

REFERENCES

- [1] R. Omar, and N. A. Rahim, "Power quality improvement in low voltage distribution system using dynamic voltage restorer (DVR)," *the 5th IEEE Conf. on Electronics and Applications*, pp. 973-978, 2010.
- [2] B. Singh, K. Al-Haddad, and A. Chandra, "A review of active filters for power quality improvement," *IEEE Trans. on Industrial Electronics*, vol.46, no.5, pp. 960-971, 1999.
- [3] D. M. Vilathgamuwa, A. A. D. R. Perera, and S. S. Choi, "Voltage Sag compensation with energy optimized Dynamic Voltage Restorer," *IEEE Trans. on Power Del.*, vol. 11, no. 3, pp. 928-936, 2003.
- [4] V. Salehi, S. Kahrobaee, and S. Afsharnia, "Power flow control and power quality improvement of wind turbine using universal custom power conditioner," *IEEE Conf. on Industrial Electronics*, pp. 1688-1692, 2006.
- [5] S. S. Mahesh, M. K. Mishra, B. K. Kumar, and V. Jayashankar, "Rating and design issues of DVR injection transformer," *the 3rd IEEE Conf. on Applied Power Electronics*, pp. 449-455, 2008.
- [6] V. K. Ramchandaramurthy, A. Arulampalam, C. Fitzer, C. Zhan, M. Barnes, and N. Jenkins, "Supervisory control of dynamic voltage restorers," *IEEE Proc. Gener. Transm. Distrib.*, vol. 151, no.1, pp. 509-516, 2004.
- [7] H. Toodeji, and S. H. Fathi. "Cost reduction and control system improvement in electrical arc furnace using DVR," *IEEE Conf. on Industrial Electronics and Applications*, pp. 211-215, 2009.
- [8] R. Madhusudan, and G. Ramamohan Rao, "Modeling and simulation of a Dynamic Voltage Restorer (DVR) for power quality problems-voltage sags and swells," *International Conf. on Advances in Engineering, Science and Management* , pp. 422-427, 2012.
- [9] M. Sharanya, B. Basavaraja, and M. Sasikala, "An overview of dynamic voltage restorer for voltage profile improvement," *International Journal of Engineering and Advanced Technology*, vol. 2, no. 2, pp. 26-29, 2012.
- [10] O. Rosli, N. A. Rahim, and S. Marizan, "Dynamic voltage restorer application power quality improvement in electrical distribution system: An overview," *Australian Journal of Basic and Applied Sciences*, vol. 5, no. 12, pp. 379-396, 2011.
- [11] T. Thakur, and G. Singh "Modelling and simulation of DVR for power quality improvement" *International Journal of Engineering Sciences Research* , vol. 2, no. 4, pp. 304-311, 2011.
- [12] M. Kavitha, T. Chandrase Khar, and D. Mohan Reddy, "Designing of dynamic voltage restorer (DVR) to improve the power quality for restructured power systems," *American Journal of Electrical Power and Energy Systems*, vol.2, no.3, pp. 94-97, 2013.
- [13] A. Venkata, and Dr. K. Narasimha Rao, "Power quality improvement using repetitive controlled dynamic voltage restorer for various faults", *International Journal of Engineering Research*, vol.2, no.1, pp. 168-178, 2012.
- [14] M. R. Banaei, S. H. Hosseini, and G. B. Gharehpetican, "Inter-line dynamic voltage restorer control using a novel optimum energy consumption strategy" *Science direct*, pp. 989-999, 2006.
- [15] P. Kumari, and V. Kumargarg, "Simulation of dynamic voltage restorer using Matlab to enhance power quality in distribution system," *International Journal of Engineering Research and Applications*, vol.3, no.4, pp.1436-1441, 2013.
- [16] M. A. Bhaskar, S. S. Dash, C. Subramani, M. J. Kumar, P. R. Gireesh, and M. V. Kumar "Voltage quality improvement using DVR", *International Conf. on Recent Trends in Information, Telecommunication and Computing*, pp. 378-380, 2010.
- [17] P. Roncero-Sánchez, E. Acha, J. E. Ortega-Calderon Vicente Felio, and A. Garcia-Cerrada, "A versatile control scheme for a dynamic voltage restorer for power-quality improvement", *IEEE Trans., Power Del.*, vol. 24, no. 1, pp. 277-284, 2009.
- [18] P. G. Gonzalez, and A. G. Cerrada "Analysis of a Neutral-Point-Connected DVR and comparison with a conventional and a transformer-less DVR", *Internal report*. Comillas, Madrid, 2010.

- [19] A. Kumar Jena, B. Mohapatra, and K. Pradhan, "Modeling and simulation of a Dynamic Voltage Restorer (DVR)," *A Project Report for the degree of Bachelor of Technology in Electrical Engineering*, Rourkela, Odisha, 2008.

Roshanak Rezaeipour was born in Tabriz, Iran. She received her Ph.D degree in electrical engineering from the Iran University of Science and Technology, Tehran, Iran in 2012. She is currently an assistant professor in department of Electrical Engineering, College of Technical and Engineering, Tabriz Branch, Islamic Azad University, Tabriz, Iran Her research interests are power system analysis, Reactive power control in power system and FACTS devices.