

Estimation of Vertical Handover Probability in an Integrated UMTS and WLAN Networks

Diganta Kumar Pathak, Manashjyoti Bhuyan, Vaskar Deka

Abstract—Vertical Handover(VHO) among different communication technologies ensuring uninterrupted and service continuity is one of the most important performance parameter in Heterogenous networks environment. In an integrated Universal Mobile Telecommunication System(UMTS) and Wireless Local Area Network(WLAN), WLAN is given an inherent priority over UMTS because of its high data rates with low cost. Therefore mobile users want to be associated with WLAN maximum of the time while roaming, to enjoy best possible services with low cost. That encourages reduction of number of VHO. In this work the reduction of number of VHO with respect to varying number of WLAN Access Points(APs) in an integrated UMTS and WLAN network is investigated through simulation to provide best possible cost effective service to the users. The simulation has been carried out for an area $(7800 \times 9006)m^2$ where COST-231 Hata model and 3GPP (TR 101 112 V 3.1.0) specified models are used for WLAN and UMTS path loss models respectively. The handover decision is triggered based on the received signal level as compared to the fade margin. Fade margin gives a probabilistic measure of the reliability of the communication link. A relationship between number of WLAN APs and the number of VHO is also established in this work.

Keywords—VHO, UMTS, WLAN, MT, AP, BS.

I. INTRODUCTION

IN the last few years a number of wireless technologies have been deployed. All these technologies differ in their properties like radio access networks, bandwidth used, service provided etc. and they have certain advantages as well as some inherent limitations. Universal Mobile Telecommunication System (UMTS) with ubiquitous coverage supports data rates [1] of 2 Mbps at higher cost. On the other hand Wireless Local Area Network(WLAN) provides data rate upto 300 Mbps at an extremely low cost within a small coverage area, resulting less mobility. Therefore both of these technologies can be complementary to each other. UMTS and WLAN can be integrated which keeps the best features of both of these technologies i.e global coverage of UMTS along with high speed and low cost of WLAN. The inherent limitations of these technologies can be eliminated in the integrated architecture. For example the low data rate of UMTS can overcome by handing over the ongoing connection to WLAN, if WLAN is available. Similarly when a mobile terminal(MT) moves out of coverage area of WLAN, it can be handed over to UMTS.

Diganta Kuamr Pathak is with the Department of Information Technology, Gauhati University, Guwahati-781014, Assam, India (e-mail: pathakdiganta1@gmail.com).

Manashjyoti Bhuyan is with the Department of Electronics and Communication Technology, Gauhati University, Guwahati-781014, Assam, India (e-mail: manashjyoti.b@gmail.com).

Vaskar Deka is with the Department of Information Technology, Gauhati University, Guwahati-781014, Assam, India (e-mail: vaskardeka@gmail.com).

The basic idea is to choose high data rate at a low cost within smaller coverage area whenever possible [2].

Mobility management in heterogeneous networks controls the handover process from one technology to the other. When received signal power level from the current network is below a threshold value, MT regularly scans corresponding frequency bands to detect available network [3]. If the signal strength is adequate a handover to the other network is attempted. The UMTS handover procedure involves complicated protocols like Radio Resource Control Protocol(RRC). RRC is responsible for paging, User Equipment(UE) measurements, cell selection etc. GPRS mobility management protocol(GMM) is used to support mobility of the MT. Mobility management in WLAN is much simpler than UMTS. As it is a IP based network, Mobile IPv4(MIPv4) protocol is used for handover management [4]. Vertical Handover(VHO) is the key performance parameter in an integrated UMTS and WLAN networks. VHO ensures the seamless roaming in an integrated UMTS and WLAN network. Users want to be associated with WLAN most of the time because of its cheapest service and it is always expected to get one alternate AP, when it moves out of coverage of the previous AP. Therefore the number of VHO is expected to be minimum to ensure best possible service with low cost.

As signal passes through a medium due to unwanted interference the signal gets faded and therefore an extra amount of RF power is radiated to overcome this phenomenon which is referred to as Fade margin. To calculate the reliability of a link Fade margin provides an important criteria. Fade margin gives a probabilistic measure of the reliability of the communication link. Each transmitter (whether UMTS or WLAN) has certain value for fade margin operating at certain transmit power having certain coverage area. The Fade Margin for UMTS and WLAN have negative value measured in dBm. The signal power level on the fade margin is unreliable for fifty percent of the total time and hence for uninterrupted link the handover process has to be completed when the signal power is well above the fade margin [5].

In this paper an algorithm is proposed to find out the frequency of VHO with respect to varying number of Access Points(APs). Applying this algorithm the number of VHO performed by a MT can be calculated in an area where a number of APs are randomly distributed while a fixed number of UMTS Base Stations(BSs) are planned. MTs are allowed to move in certain directions according to randomly chosen slope. The handover decision has been taken based on received signal power level compared to fade margin. Finally Monte Carlo Averaging has been applied to obtain

better performance. Monte Carlo Averaging is a problem solving technique used to approximate the probability of certain outcomes by running multiple trial runs, using random variables. In telecommunications, for planning a wireless network design must be proved to work for a wide variety of scenarios that depend mainly upon certain parameters like number of users, their locations and the services they want to use. Monte Carlo methods are typically used to generate these users and their states. The network performance is then evaluated and, if results are not satisfactory, the network design goes through an optimization process.

The rest of the paper is organized as follows. The proposed algorithm is discussed in Section II. Section III describes the Base Station Planning in the simulation area using Hexagonal Geometry. In Section IV different path loss models that are used for prediction of received signal strength for both UMTS and WLAN are described briefly. A brief discussion about the simulation scenario and the analysis of the obtained results is given in Section V. Finally Section VI concludes the paper.

II. PROPOSED ALGORITHM

The proposed algorithm is shown below(Algorithm 2). The algorithm proposed here consider an area where a number of UMTS BSs are planned using cellular geometry(Hexagonal geometry). A number of WLAN APs are allowed to place randomly in the area. There are MTs which start(switch on) randomly at any point in the area and allowed to move in any direction starting from its initial point. The direction of movement is determined by a randomly selected slope. Each of the MT is allowed to move in different direction fifty times and finally the average value of number of VHO is considered. The MTs will associate with either AP or BS and handover from one network to another takes place during its movement. The selection of the appropriate network is controlled by the first algorithm(Algorithm 1). This algorithm will take handover decision comparing the received signal strength of different networks with respect to fade margin. The received signal power level is estimated using the path loss models discussed in section IV. The algorithm gives an inherent priority to WLAN because of its cost effectiveness and high data rate. The algorithm 2 uses algorithm 1 to choose the best network.

Different parameters used to describe the algorithms are described below:

- * BS_power: received signal strength from the nearest UMTS BS.
- * AP_power: received signal strength from the nearest WLAN AP.
- * Whandoff_threshold: indicates the handover threshold for WLAN. The RSSI(received signal strength indicator) value received by a MT attached to a WLAN network is always expected to be well above the handover threshold of the respective WLAN network for uninterrupted communication. MT is expected to handover to an alternate network before the RSSI value from the current network decreases below handover threshold.
- * Uhandoff_threshold: indicates handover threshold for the UMTS network. MT associated

with a UMTS network having RSSI value below the handover threshold is unreliable for an ongoing communication. Therefore the handover process has to be completed above the handover threshold.

- * AP_fade_margin: It indicates the fade margin of WLAN network.
- * BS_fade_margin: It denotes the fade margin of UMTS network.
- * Diff_AP: It assigns the difference between AP_fade_margin and AP_power.
- * Diff_BS: The difference between BS_fade_margin and BS_power is indicated by Diff_BS.
- * Handoff_count: It is a counter that is used to count the number of handover encountered during its movement directed by a randomly selected slope.
- * mc_handoff: It is used for calculating the monte carlo averaging value of handover which runs multiple number of trial(Here 50 number of trial run is considered). In every trial run the MT is allowed to move in different direction. Finally the handover count is divided by 50 to get the net effect of handover count.
- * State_MT: It is a dynamic array that is used to save the state of the MT i.e whether the MT is connected to AP or BS. If MT is connected to AP then state of the MT is saved as 1 otherwise 0.
- * Total_Handoff: It is also a dynamic array that is used to save the total number of VHO takes place for a certain number of MTs.

III. BASE STATION PLANNING

While considering the geometric shape of a cell that covers an entire area without overlap and with equal area, the hexagonal shape is considered to be the best because of its close proximity towards circular radiation pattern [6]. While modeling hexagonal cell with certain coverage area, the Base Station transmitter are usually placed at the center of the cell(in case of omni directional antenna). Here the simulation scenario is considered to cover an area of $(7800 \times 9006)m^2$ with cell radius of 2.6 Km as shown in the fig 2. Within this area, eight Base Stations can be planned with the specified cell radius. The coordinates of the Base Stations are shown in the fig 2. The coordinates of the BS are calculated using hexagonal geometry [7]. Let us consider a single cell to illustrate the procedure as shown in fig 1. Here O is the centre of the hexagonal cell and R is the radius. OA is perpendicular to BC. The $\angle OAB = 60^\circ$. Now from the right angled triangle OAB we get

$$\begin{aligned} \frac{AB}{OB} &= \cos 60^\circ \\ \implies AB &= OB \times \frac{1}{2} \\ \implies AB &= \frac{R}{2} \end{aligned} \quad (1)$$

Algorithm 1 Algorithm to find Nearest AP or BS

```

1: procedure NEARESTCONNECTED(X,Y)
2:   Find the nearest AP and BS from (X,Y)
3:   Find the received power level from the nearest AP
   (AP_power) and BS (BS_power)
4:   if ((AP_power > Whandoff_threshold) &
   (BS_power < Uhandoff_threshold)) then
5:     MS is connected to AP
6:   else if ((AP_power < Whandoff_threshold)
   & (BS_power > Uhandoff_threshold)) then
7:     MS is connected to BS
8:   else if ((AP_power > Whandoff_threshold)
   & (BS_power > Uhandoff_threshold)) then
9:     MT is connected to AP
10:  else if ((AP_power < Whandoff_threshold)
   & (BS_power < Uhandoff_threshold)) then
11:    Find out the difference between AP fade margin
   and AP_power
12:    Diff_AP = (AP_fade_margin - AP_power)
13:    Find out the difference between BS fade margin
   and BS_power
14:    Diff_BS = (BS_fade_margin - BS_power)
15:    if (Diff_AP < (Diff_BS)) then
16:      MT is connected to AP
17:    else
18:      MT is connected to BS
19:    endif
20:  endif
21: end procedure

```

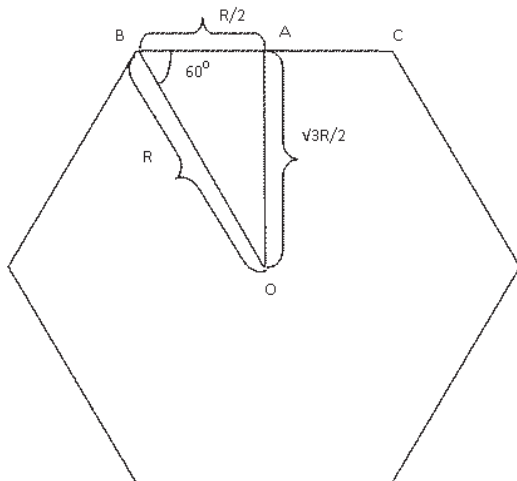

Fig. 1 UMTS Cell

Algorithm 2 Algorithm for finding Handover count

```

1: Size of the simulation area is S = (7800 × 9006)m2.
2: Plan the number of BS in S
   (refer to the fig 2)
3: for AP=10 to 6000 in step of 50 do
4:   i = 0                                     ▷ Variable Declaration
5:   for ma=1 to 50 in step of 1 do
6:     mc_handoff = 0                         ▷ Variable Declaration
7:     Randomly distribute the number of APs in S.
8:     Handoff_Count = 0                     ▷ Variable Declaration
9:     for MT=1 to 200 in step of 1 do
10:      Choose a slope randomly from a set of slopes
       0°, 45°, 90°, 135°, 180°, 225°, 270°, 315°.
11:      Find a point (X,Y) randomly in S from where the
       MT can move (directed by the slope).
12:      j = 0                                 ▷ Variable Declaration
13:      do
14:        NEARESTCONNECTED(X,Y)
15:        if MT is AP connected then
16:          State_MT[j] = 1
17:        else
18:          State_MT[j] = 0
19:        endif
20:        if (j > 0) then
21:          if (State_MT[j-1] = 1 &
             State_MT[j] = 0) then
22:            Handoff_Count ++
23:          else if (State_MT[j-1] = 0 &
                  State_MT[j] = 1) then
24:            Handoff_Count ++
25:          endif
26:        endif
27:        j ++
28:      while all points in MT trajectory completed
29:    end for
30:    mc_handoff += Handoff_Count
31:  end for
32:  mc_handoff = mc_handoff/50
33:  Total_Handoff[i] = mc_handoff
34:  i ++
35: end for

```

Similarly

$$\begin{aligned}
 \frac{OA}{OB} &= \sin 60 \\
 \Rightarrow OA &= OB \times \frac{\sqrt{3}}{2} \\
 \Rightarrow OA &= \frac{\sqrt{3}}{2} \times R \quad (2)
 \end{aligned}$$

Using the above equations (refer to(1) and(2)) the coordinates of the BSs can be calculated.

A. Coordinates of BS1

The coordinates of the BS1 is assumed to be placed at the origin. It is taken as a reference point to calculate the

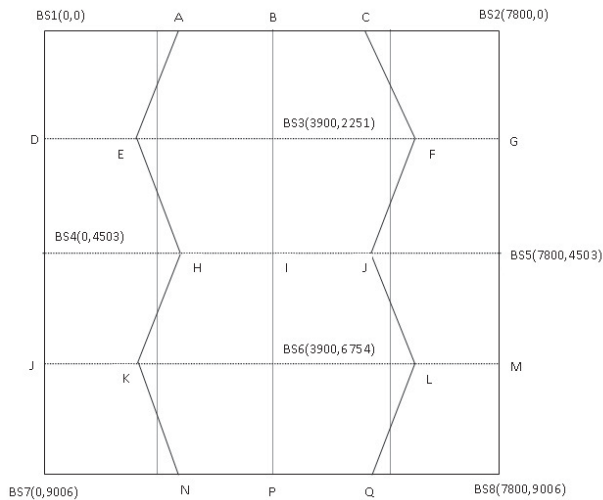

Fig. 2. UMTS Base Station Planning in the Simulation area

coordinates of other BSs.

B. Coordinates of BS2

The base station BS2 lies in X axis. So the y coordinate will be 0. The x coordinate can be calculated from the coordinate of the cell vertex C. The cell vertex A is at a distance equal to the radius ($R=2600\text{m}$) of the cell from BS1. As A lies in X axis, the coordinates of A will be $(2600,0)$. The length of AB will be $R/2 = 2600/2 = 1300$ (refer to (1)). So the coordinates of B will be $(3900,0)$. Again $AB=BC=R/2 = 2600/2 = 1300$. So the coordinates of C will be $(5200,0)$. Again the distance between C and BS2 is $R = 2600\text{ m}$ and it lies in X axis. So the coordinates of BS2 becomes $(7800, 0)$.

C. Coordinates of BS3

From the fig 2, it is obvious that the x coordinate of BS3 will be same as B. To calculate the y coordinate, there is a need to find out the distance between B and the BS3. The distance between B and the BS3 is $\frac{\sqrt{3}}{2}R$ (refer to (2)). If the coordinates of BS3 is (X,Y) then

$$\sqrt{(X - 3900)^2 + (Y - 0)^2} = \frac{\sqrt{3}}{2} \times R \quad (3)$$

Here x coordinate of BS3 is 3900 i.e $X=3900$ and radius $R=2600\text{m}$. Putting the values of X and R in (3), the value of Y is evaluated as $Y=2251$. So the coordinates of BS3 will be $(3900, 2251)$.

D. Coordinates of BS4

The x coordinate of BS4 is same as BS1 which is obvious from the fig 2. The distance between BS1 and D will be equal to $\frac{\sqrt{3}}{2} \times R$ (refer to (2)). Similarly the distance between D and BS4 will be equal to $\frac{\sqrt{3}}{2}R$. Therefore the distance between

BS1 and BS4 becomes twice that of $\frac{\sqrt{3}}{2} \times R$. If the coordinates of BS4 is (X,Y) then

$$\sqrt{(X - 0)^2 + (Y - 0)^2} = 2 \times \frac{\sqrt{3}}{2} \times R \quad (4)$$

Solving the above equation for $X=0$ and $R=2600$, the y coordinate of BS4 is evaluated as $Y=4503$. So the coordinates of BS4 will be $(0, 4503)$.

E. Coordinates of BS5

It is evident from the fig 2 that the y coordinate of BS5 is same as BS4. The distance between BS4 and H will be equal to the radius (R) of the cells. Similarly both the distance between H and J and the distance between J and BS5 will be equal to R. Therefore the distance between BS4 and BS5 becomes thrice that of radius (R) of the cells. If the coordinate of BS5 is (X,Y) then

$$\sqrt{(X - 0)^2 + (Y - 4503)^2} = 3 \times R \quad (5)$$

Solving the above equation for $Y=4503$ and $R=2600$, the X coordinate of BS5 will be $X=7800$. So the coordinates of BS5 becomes $(7800, 4503)$.

F. Coordinates of BS6

The x coordinate of BS6 is same as BS3 (refer to the fig 2). The distance between BS3 and I will be $\frac{\sqrt{3}}{2} \times R$ (refer to (2)). Similarly the distance between I and BS6 will be $\frac{\sqrt{3}}{2} \times R$. So the distance between BS3 and BS6 will be twice that of $\frac{\sqrt{3}}{2} \times R$. If the coordinate of BS6 is (X,Y) then

$$\sqrt{(X - 3900)^2 + (Y - 2251)^2} = 2 \times \frac{\sqrt{3}}{2} \times R \quad (6)$$

Solving the above equation for $X=3900$ and $R=2600$, the y coordinate of BS6 will be $Y=6754$. So the coordinates of BS6 becomes $(3900, 6754)$.

G. Coordinates of BS7

The x coordinate of BS7 is same as BS4 (refer to the fig 2). The distance between BS4 and J will be equal to $\frac{\sqrt{3}}{2} \times R$ (refer to (2)). Similarly the distance between J and BS7 will be equal to $\frac{\sqrt{3}}{2}R$. Therefore the distance between BS4 and BS7 becomes twice that of $\frac{\sqrt{3}}{2} \times R$. If the coordinates of BS7 is (X,Y) then

$$\sqrt{(X - 0)^2 + (Y - 4503)^2} = 2 \times \frac{\sqrt{3}}{2} \times R \quad (7)$$

Solving the above equation for $X=0$ and $R=2600$, the y coordinate of BS4 becomes $9006(Y=9006)$. So the coordinates of BS4 will be $(0, 9006)$.

H. Coordinates of BS8

The x coordinate of BS8 is same as BS5 which can be intimated from the fig 2. The distance between BS5 and M will be equal to $\frac{\sqrt{3}}{2} \times R$ (refer to (2)). Similarly the distance between M and BS8 will be equal to $\frac{\sqrt{3}}{2}R$. Therefore the distance between BS5 and BS8 becomes twice that of $\frac{\sqrt{3}}{2} \times R$. If the coordinates of BS8 is (X,Y) then

$$\sqrt{(X - 7800)^2 + (Y - 4503)^2} = 2 \times \frac{\sqrt{3}}{2} \times R \quad (8)$$

Solving the above equation for X=7800 and R=2600, the y coordinate of BS8 will be 9006(Y=9006). So the coordinates of BS8 will be (7800, 9006).

IV. PATH LOSS MODEL

When a signal transmitted from a transmitter passes through medium, it attributed to phenomenon like reflection, diffraction and scattering [6]. Due to these phenomena the signal reaches the receiver by two or more paths each of having different length. The interaction between these signals causes multipath fading and the strength of the signal decreases as the distance between the transmitter and the receiver increases. A rare worst case occurs when waves travelling along different paths end up completely out of phase and cancel each other. To predict the average received signal strength at a distance from the transmitter propagation models have been used. These models have traditionally been focused on predicting the average received signal strength from the transmitter. In a mobile communication system the radio transmission often takes place in irregular terrain. In estimating the path loss, the terrain structure plays a vital role. The terrain structure may vary from simple curved surface to mountain surface. A number of outdoor propagation have been proposed to predict the path loss over irregular terrain.

The technology behind UMTS is much more complicated compared to GSM which in turn makes the UMTS network planning much more complicated than GSM voice planning [8]. Therefore it is impossible to think of minimum received signal level to achieve one maximum interference threshold in UMTS. Each service needs a specific threshold values and also network behaviour changes with traffic. Therefore the need for an accurate propagation prediction is now more vital [8]. As there is a difference in the frequency used by UMTS and GSM, the Propagation prediction models used in GSM systems are not applicable UMTS.

In urban areas Okumura's model is widely used for signal prediction. This model is applicable in the frequency range 150 MHz to 1920 MHz and distances of 1 to 100 Km. Hata Model is also a radio propagation model based on Okumura's model. Hata Model provides separate model for varying environments like urban areas, suburban areas etc. The propagation predictions of Hata Model compare closely with the original Okumura's Model as long as distance exceeds 1 km. This model is well suited for large cell mobile systems, but not for personal communications systems (PCS) which have cells on the order of 1 Km radius [6]. For personal communications systems PCS extension of Hata Model is used

within a small coverage area. PCS extension of Hata Model was provided by the European Cooperative for Scientific and Technical Research (EURO-COST) and it is used here as outdoor propagation prediction model for WLAN. Similarly 3GPP has specified separate propagation prediction model for different environments in their technical reports [9]. UMTS path loss Model for Outdoor to Indoor and Pedestrian Test Environment is considered here.

A. COST-231 Hata Model

The COST-231 working committee which was formed by the European Cooperative for Scientific and Technical Research (EURO-COST) developed the extended version of the Hata Model. COST-231 proposed the following formula to extend Hata's model to work with 2 GHz band. The proposed model for path loss is:

$$L_{50}(\text{urban}) = 46.3 + 33.9 \log f_c - 13.82 \log h_{te} - a(h_{re}) + (44.9 - 6.55 \log h_{te}) \log d + C_M \quad (9)$$

Where $a(h_{re})$ is the correction factor for the effective antenna height which is a function of the size of the coverage area. For a small to medium sized city, the mobile antenna correction factor is given by

$$a(h_{re}) = (1.1 \log f_c - 0.7)h_{re} - (1.56 \log f_c - 0.8)dB$$

for a large urban area, it is given by

$$a(h_{re}) = 8.29(\log 1.54h_{re})^2 - 1.1dB \text{ for } f_c \leq 300MHz \quad (10)$$

$$a(h_{re}) = 3.2(\log 11.75h_{re})^2 - 4.97dB \text{ for } f_c \geq 300MHz$$

$C_M = 0 \text{ dB}$ for a medium size city and suburban area

$$C_M = 3 \text{ dB} \text{ for metropolitan centers} \quad (11)$$

The COST-231 extension of the Hata Model is restricted to the following range of parameters:

f_c : 1500 MHz to 2000 MHz

h_{te} : 30m to 200m

h_{re} : 1m to 10 m

d: 1km to 20 km

B. UMTS path loss Model for Outdoor to Indoor and Pedestrian Test Environment

According to the 3GPP technical report [9] the path loss model which is applicable for the test scenarios of outdoor to indoor and pedestrian test environment:

$$L = 40 \log(R) + 30 \log(f) + 4921 \log(f) + 80dB \quad (12)$$

Where:

R is the base station - mobile station separation in kilometres.

f is the carrier frequency of 2000 in MHz.

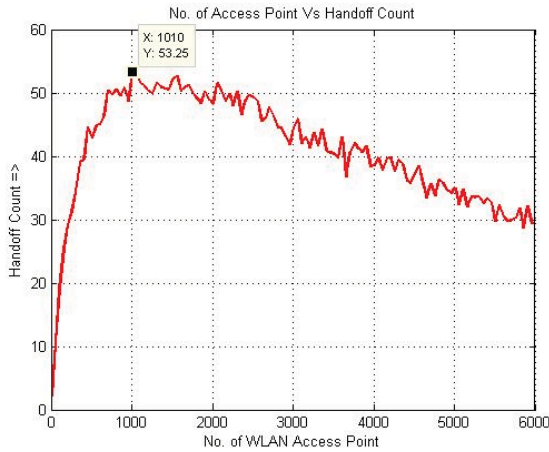

Fig. 3. Simulation Scenario

V. SIMULATION

The simulation has been carried out for outdoor to indoor and pedestrian Test Environment. The area considered here for simulation is $(7800 \times 9006)m^2$. Eight UMTS BSs are planned in the simulation area as shown in fig 2. WLAN APs have been distributed randomly in the simulation area. Two hundred MTs are considered for simulation, which have also been distributed randomly while simulating the scenario. The MTs can start (switched on) at any point in the simulation area and are allowed to move in certain direction. The direction of movement is determined by a randomly chosen slope from a set of slopes with respect to X axis. The set of slopes considered here are $[0^0, 45^0, 90^0, 135^0, 180^0, 225^0, 270^0, 315^0]$. The decision of association and disassociation of MT with AP or BS has been carried out with the help of received signal power level which is compared with fade margin as described in the algorithm 2. To determine the received signal power level, different path loss models are used for UMTS and WLAN. COST-231 Hata model is used for prediction of received signal strength radiated from WLAN AP and 3GPP specified path loss model [9] (Outdoor to Indoor and Pedestrian Test Environment) is used for predicting the received signal strength from UMTS BS.

At each point in the trajectory of the MTs, the association (whether AP or BS) is compared with the association of the previous point. If both of these doesn't match, one VHO is reported and `handoff_count` is incremented. The process is repeated for each MT. When the process has been completed for all the MT, the total handover count for the specified number of APs is recorded. This whole process is repeated for fifty times and finally take the average of it (monte carlo averaging for better accuracy), which will give the frequency of VHO for that specified number of APs. Then the number of APs are incremented and the whole process is repeated. The whole simulation work can be summarized by the Algorithm 2. During time of simulation different parameters has been set to certain value as shown in Table 1.

TABLE I
SIMULATION PARAMETERS

Parameter	Values
Simulation Area	$(7800 \times 9006)m^2$
Number of Mobile Station	200
Handoff threshold	$-66dBm$
Height of the receiver	1.5 Meter
Antenna height of the Base station	50Meter
Antenna height of the WLAN Access Point	4 Meter
Transmit power of Access Point	17dBm
Transmit power of Base Station	43dBm
Bandwidth of WCDMA	5 MHz
Bandwidth of WLAN	22 MHz
Receiver Sensitivity	-86dBm
WLAN operating frequency	2.4 GHz
UMTS operating frequency	2.1 GHz
UMTS Node B tower gain	14 dBi
Antenna gain for Omni directional antenna in WLAN	2 dBi
UMTS data rate	384 kbps
WLAN data rate	11 Mbps
Noise Figure	4dB

A. Simulation Results and Analysis

Fig 3 shows the behaviour obtained from the simulation. Here in this graph WLAN APs are plotted in X axis while `Total_Handoff` is plotted in Y axis. From the resultant plot it is observed that the frequency of VHO increases with the increase in the number of APs upto a maximum threshold. But after the handover frequency reaches a maximum value, it decreases with the increases in the number of APs.

When a small number of APs are distributed in the simulation area, the MTs are associated with BS most of the time although it wants to be associated with AP. This is because of the smaller coverage area of WLAN where there is less chances of preferable horizontal handover(i.e handover from WLAN to WLAN). When the number of APs increases, the WLAN coverage area increases. But if these number APs unable to build some overlapped WLAN network, then the MT has to finally handed over to UMTS during its movement and as a result the frequency of VHO increases. In this way when the number of APs approaches towards 1010, the MTs find lots of APs to be associated but not so much that it can associate only with WLAN and switch from one AP to another. Because of the higher priority given to WLAN over UMTS, there will be wild swing between UMTS and WLAN resulting greater number of VHO. After a maximum handover frequency is reached for the number of APs equal to 1010, frequency of handover decreases with the increase in number of APs. During this time the number of the randomly distributed APs are sufficient to build some WLAN overlap network in some portion of the simulation area. Within this

area MTs find alternate AP to be connected while moving out of coverage from the previous AP. As the number of AP increases gradually, the area of the overlapped network increases and the MTs will associate with the APs most of the time resulting less number of VHO. Although only the MTs are allowed to move in a straight direction, random motion can also be inferred from this simulation. This is because of the monte carlo averaging applied during simulation where the same MT is allowed to move in different direction fifty times and total number of VHO is calculated. The average of this total number of VHO gives the final handover frequency.

The reduction of VHO with respect to increase in number of APs can be describe by the graph obtained in the simulation as shown in fig 3. This result can be expressed in terms of fourth degree polynomial equation as follows (refer to (13)). The independent variable X in (13) refers to the number of APs while the frequency of VHO is expressed as a function of X.

$$f(X) = (P1 \times X^4 + P2 \times X^3 + P3 \times X^2 + P4 \times X + P5)/(X^2 + Q1 \times X + Q2) \quad (13)$$

where

$$P1=4.481 \times 10^{-7}$$

$$P2=-0.01028$$

$$P3=76.41$$

$$P4=-93.95$$

$$P5=-6.283$$

$$Q1=313.5$$

$$Q2=29.12$$

VI. CONCLUSION AND FUTURE SCOPE

In this paper a cost effective way of seamless roaming in heterogenous networks is suggested where WLAN works as a complementary network to the UMTS network. The algorithm advised here is designed for estimating the frequency of VHO in an integrated UMTS and WLAN networks. The frequency of VHO can be reduced by increasing the density of WLAN APs. The maximum number of VHO can be evaluated from the derived equation(refer to (13)). From the equation which is being derived from the results obtained during simulation can be used for estimating the frequency of VHO in an integrated UMTS and WLAN networks.

Although the BSs has been planned using hexagonal geometry, the APs are randomly distributed. WLAN AP can also be optimally placed in an area [10]. It will reduced the number of APs as well as enhance proper utilization of resources. Again the handover decision can be taken based on the prediction of traveling distance of a MT inside a WLAN cell [11], which reduces unnecessary handover. This will be done at the next level of work.

REFERENCES

- [1] Shiao-Li Tsao and Chia-Ching Lin , *Design and Evaluation of UMTS WLAN Interworking Strategies*, Vehicular Technology Conference, 2002. Proceedings. VTC 2002-Fall. 2002 IEEE 56th (Volume:2) Page No 777 - 781.
- [2] S. Mohanty, "A new architecture for 3G and WLAN integration and inter-system handover management", Springer Journal of Wireless Networks, December 2006, Volume 12, Issue 6, pp 733-745

- [3] Tom Van Leeuwen , Ingrid Moerman, Piet Demeester, "Location assisted fast vertical handover for UMTS/WLAN overlay networks" .Elsevier Computer Communications 29 (2006) 2601-2611.
- [4] George Lampropoulos, Nikos Passas, Lazaros Merakos, Alexandros Kaloxylos, "Handover Management Architectures in Integrated WLAN/Cellular Networks", IEEE Communication Surveys fourth quarter 2005, Volume 7, NO. 4.
- [5] Diganta Kumar pathak, Manasjyoti Bhuyan, Vaskar Deka and Maushumi Barooah, "Constraint Estimation for RSSI based Handoff between UMTS and WLAN". Proceedings of IEEE 2013 1st International Conference on Emerging Trends and Applications in Computer science.
- [6] T S Rappaport, "Wireless Communications Principles and Practise" .Second Edition Pearson Education.
- [7] V.H MAC DONALD; "The Cellular Concept", The Bell System Technical Journal Volume 58, No. 1 January 1979.
- [8] M. Coinchon, A. P. Salovaara, and J. E. Wagen, "The Impact of Radio Propagation Predictions on Urban UMTS Planning" .2002 International Zurich Seminar on Broadband Communications Access Transmission-Networking, February 19-21, Zurich, Switzerland, 2002. 1998.
- [9] Universal Mobile Telecommunications System (UMTS); "Selection procedures for the choice of radio transmission technologies of the UMTS ", (UMTS 30.03 version 3.1.0) TR 101 112 V3.1.0 (1997-11).
- [10] S. Kouhbor, Julien Ugon, Alex Kruger, Alex Rubinov,"Optimal Placement of Access Point in WLAN Based on a New Algorithm", International Conference on Mobile Business, 11-13 July, 2005
- [11] Xiaohuan Yan, Nallasamy Mani and Y. Ahmet Sekercioglu, "A Traveling Distance Prediction Based Method to Minimize Unnecessary Handovers from Cellular Networks to WLANs", IEEE COMMUNICATIONS LETTERS, VOL. 12, NO. 1, JANUARY 2008.



Diganta Kumar Pathak graduated in Physics and then did his masters in Computer Applications from Gauhati University, Assam, India. in the year 2007 and 2010 respectively. He also completed MTech in Information Technology from the same university in the year 2013. Presently he is working as Junior Research Fellow in the Department of Computer Applications, Assam Engineering College. His area of interest includes Wireless Networks and heterogeneous networks.



Manasjyoti Bhuyan is presently working as Research Associate at the Department of Electronics and Communication Technology (ECT), Gauhati University, Guwahati, Assam, India, completed M.Tech. in Electronics and Communication Technology from Gauhati University, Guwahati, India in 2014. His areas of interest includes Signal Processing for Communication, Intelligent transceiver design etc. He has authored a few research papers.



Vaskar Deka received the BSc and MSc in Computer Science from the Gauhati University, India in the year 2006 and 2008 respectively. He also received MTech in Information Technology from Tezpur University, India in the year 2010. Currently he is working as assistant professor in the Department of Information Technology, Gauhati University and also a PhD candidate in his department itself. His current area of research interests are in the field of Wireless Networks, Smart Environment, etc.