

Modeling and Simulation of Axial Fan Using CFD

Hemant Kumawat

Abstract—Axial flow fans, while incapable of developing high pressures, they are well suitable for handling large volumes of air at relatively low pressures. In general, they are low in cost and possess good efficiency, and can have blades of airfoil shape. Axial flow fans show good efficiencies, and can operate at high static pressures if such operation is necessary. Our objective is to model and analyze the flow through AXIAL FANS using CFD Software and draw inference from the obtained results, so as to get maximum efficiency. The performance of an axial fan was simulated using CFD and the effect of variation of different parameters such as the blade number, noise level, velocity, temperature and pressure distribution on the blade surface was studied. This paper aims to present a final 3D CAD model of axial flow fan. Adapting this model to the available components in the market, the first optimization was done. After this step, CFX flow solver is used to do the necessary numerical analyses on the aerodynamic performance of this model. This analysis results in a final optimization of the proposed 3D model which is presented in this article.

Keywords—ANSYS CFX, Axial Fan, Computational Fluid Dynamics (CFD), Optimization.

I. INTRODUCTION

THE axial flow fan is extensively used in many engineering applications. This type of fan is used in a wide variety of applications, ranging from small cooling fans for electronics to the giant fans used in wind tunnels. Axial flow fans are applied for air conditioning and industrial process applications. Its adaptability has resulted in implementation into large scale systems, from industrial dryers to automotive engine cooling and in-cabin air recirculation systems [1], [2]. The extended use of axial flow fans for fluid movement and heat transfer has resulted in detailed research into the performance attributes of many designs. Numerical investigations have been performed to quantify the performance of axial fans and their flow characteristics [3]. Axial fans blow air along the axis of the fan, linearly, hence their name. The axial-flow fans have blades that force air to move parallel to the shaft about which the blades rotate [4].

With the expressive computer capability and extensive development in the simulation field, CFD have drawn attention in recent years. With the help of CFD, the complex 3-D geometries of equipment can now be modeled with only minor simplifications [5]. CFD models, if created correctly, can account for the complex flows in equipment. CFD models for axial fans have been used to evaluate the flow behavior and characteristics. The models provide sufficiently accurate predictions over a range of operating conditions, which are not possible using other methods. In this paper, CFD was used to

model the flow passing through an axial fan. The objective was to determine ways to increase the efficiency.



Fig. 1 Axial fan assembly

Axial flow fans, while incapable of developing high pressures, they are well suitable for handling large volumes of air at relatively low pressures [6]. In general, they are low in cost and possess good efficiency, and can have blades of airfoil shape. The operating principle of axial-flow fans is simply deflection of air. Flow can be decomposed into two components: axial velocity and tangential or circumferential velocity. Axial velocity is the desired velocity since it moves air from/to the desired spaces and tangential velocity is an energy loss in axial fans or it can be converted into static pressure as in case of vane axial fans.

II. EXPERIMENTATION

The first step is to identify a typical axial flow fan that can be reproduced as a 3-D CAD Solidworks® software engineering drawing package (Fig. 2).

The 3-D models are then imported into the CFD software, remodeled into different sections, and refined to generate a finite volume meshing. This is a crucial step, where details of the geometrical shape need to be defined precisely. The flow domain is also created (Fig. 3), and the final meshing of all components needs to be accurate. Any errors in the drawings and flow area need to be corrected before continuing.

Hemant Kumawat is a Mechanical Engineer, from VIT University, Vellore, Tamil Nadu, India (2014) (phone: +917073195809; e-mail: hemantkumawat1991@gmail.com).

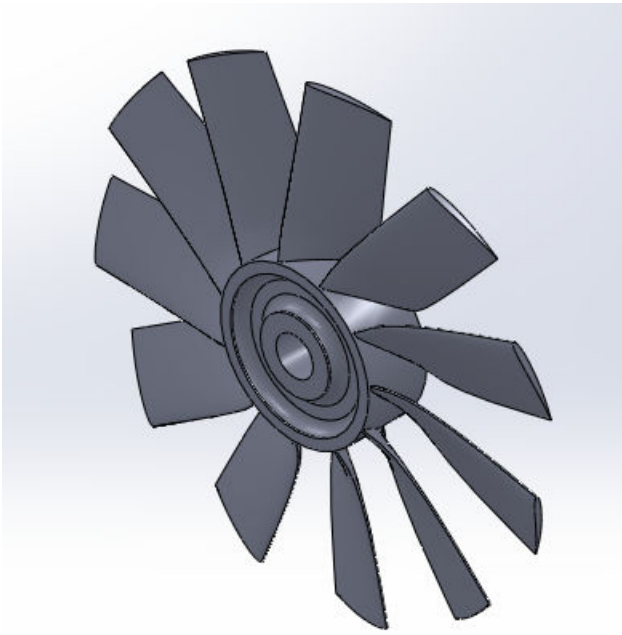

Fig. 2 Solidworks CAD model of fan

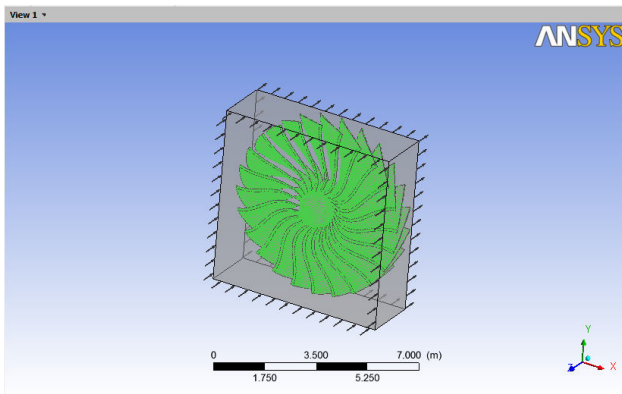

Fig. 3 Computational domain of fan

The second step is to import the files into the CFD code preprocessor, which will solve the flow equations. Here, the flow fields boundary conditions are set. These include inlet air mass flow, outlet pressure, fluid properties, and flow domain characterization, such as moving internal zone and stationary solid walls. The next step is to set the simulation process as a 3-D steady and turbulent problem (Fig. 4).

The simulation is preceded with the CFD code processing the data, applying the basic theory of fluid mechanics by balancing the mass continuity and momentum equations in numerical form and thereafter producing numerical predictions of the flow variables. The problem setup process is completed by defining the boundary conditions, solver controls, and convergence monitors. Assuming the flow to be ideal and dry air at standard atmospheric pressure, the boundary conditions include fixed wall, moving internal zone,

zero pressure at outlet, and variable mass flow rate at inlet. The residual values of all variables solved are monitored during the iteration process. This iteration process needs to be monitored for convergence and repeated if the numerical error conditions are not satisfied. The final step is to analyze the output data and present them in the form of velocity streamline (Fig. 5) and contour plots (Fig. 6).

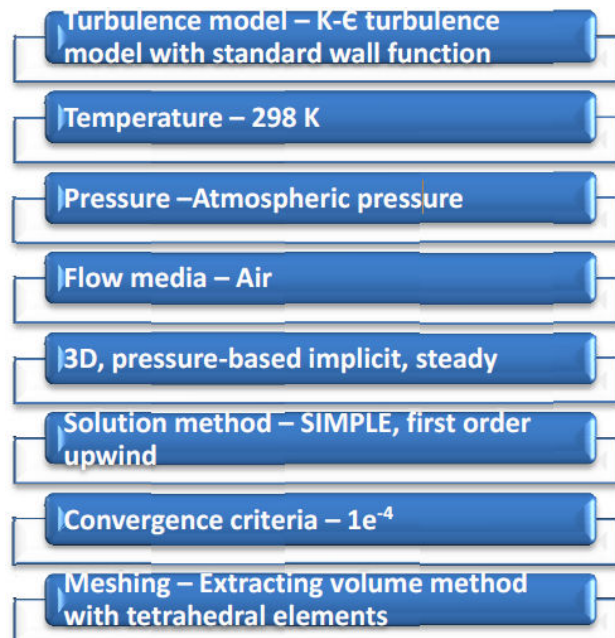

Fig. 4 Simulation parameters

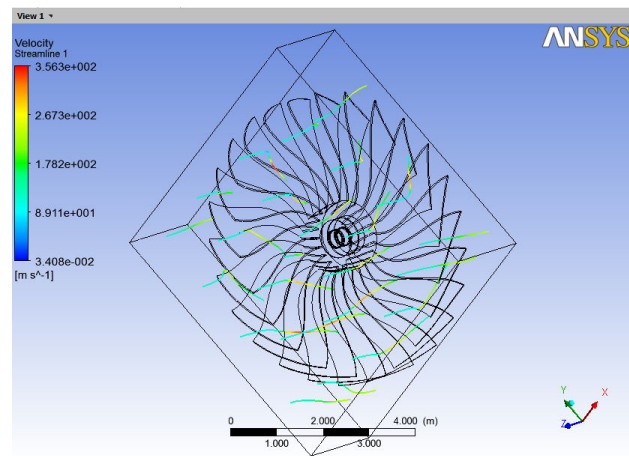

Fig. 5 Velocity streamline of fan

III. RESULTS AND DISCUSSION

On post-processing the numerical CFD results, the observations are presented as velocity streamlines, temperature contour plots, and static pressure contour plots. Optimized design results were then compared with initial design for temperature contour and velocity streamline and

presented in the form of contour plots. Results are compiled separately for initial and optimized designs.

the high temperature melting. Blade life is highly decreased. Temperature of the output air is also increased. Efficiency goes down.

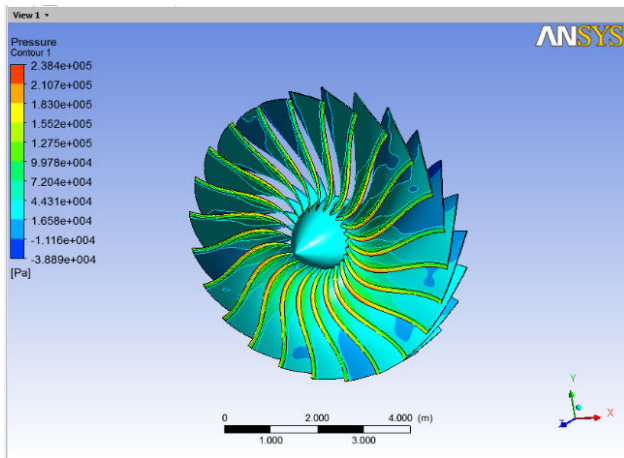

Fig. 6 Pressure contour of fan

A. Initial Design

Initially designed fan is having 7 blades. For initially designed fan, results were compiled for air flowing at a rate of 22 m/s and having the outlet pressure as atmospheric. Fig. 7 shows the turbulence kinetic energy contour plot of initially designed fan.

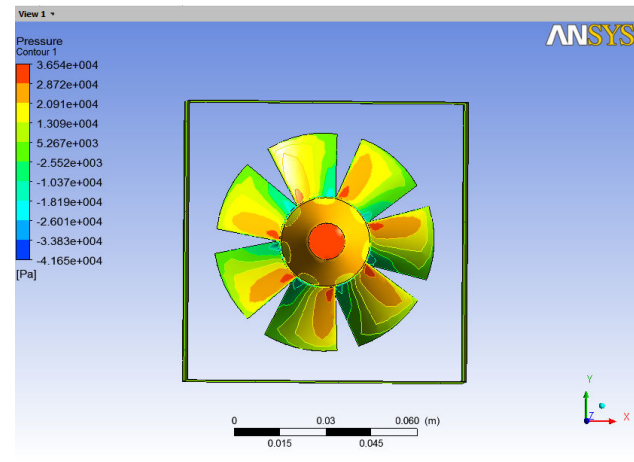

Fig. 8 Pressure contour of initially designed fan

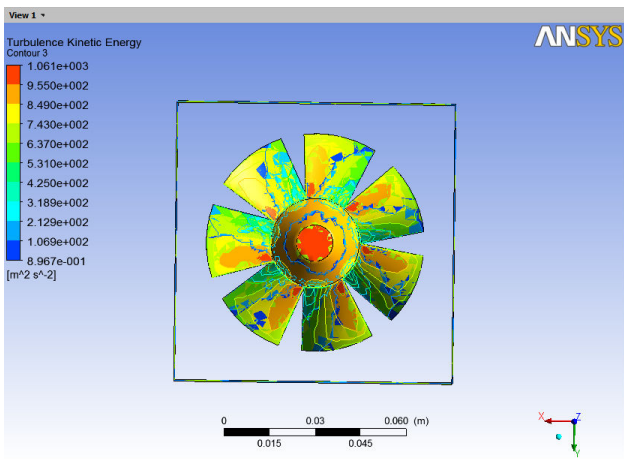

Fig. 7 Turbulence K.E. contour of initially designed fan

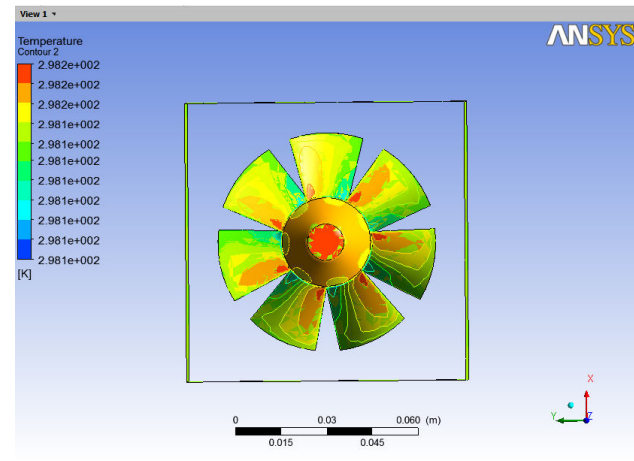

Fig. 9 Temperature contour of initially designed fan

Fig. 8 shows the pressure contour of initially designed axial fan. By observing the pressure contour, pressure ranges from negative to positive scale; hence, creating a pressure zone at the outlet.

Fig. 9 shows the temperature contour of initially designed axial fan. Variation in temperature occurs because of room temperature of air and frictional heating. Temperature variation is not uniform on the blade surface as seen in the figure. Color (showing temp contour) is drastically changing. Sudden change in temperature on the blade surface will lead to the formation of thermal cracks which can damage the blade. Moreover, the airfoil design of the blade gets distorted due to

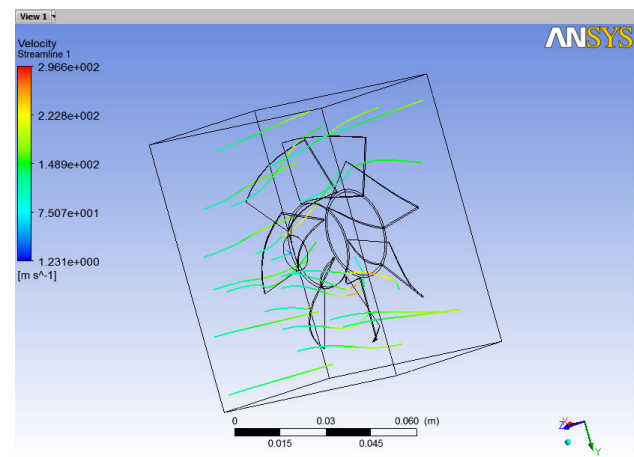

Fig. 10 Velocity streamline of initially designed fan

Fig. 10 shows the velocity streamlines of initially designed fan. By observing the plot, velocity streamlines are not uniform over fan wheel which implies that flow is not uniform. Large variation in velocity can be seen across the blade. As we can see from Fig. 10, the colour of the streamlines changes drastically as we move across the blade. Moreover, there is a reduction in velocity at outlet. This non uniform flow will result in huge noise and acoustic problems and will decrease the overall efficiency.

B. Optimized Design

Optimized designed fan is having 11 blades. For optimized designed fan results were compiled for same working conditions as for the initially designed fan - air flowing at a rate of 22 m/s and having the outlet pressure as atmospheric. Fig. 8 illustrates the temperature contour of optimized designed fan.

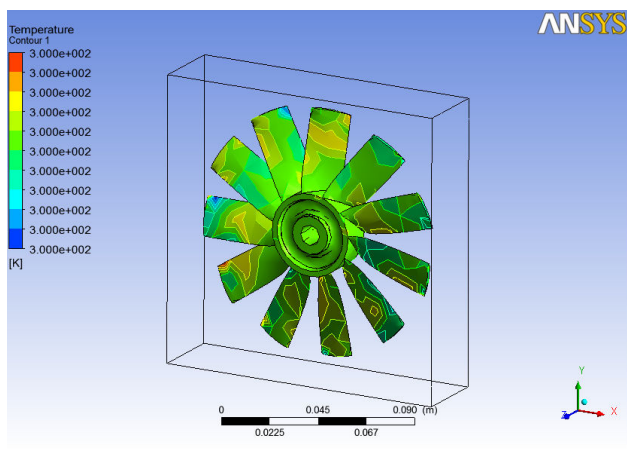

Fig. 11 Temperature contour of optimized designed fan

Fig. 11 shows the temperature contour of optimized designed axial fan. Variation in temperature occurs because of room temperature of air and frictional heating. Temperature variation is almost uniform on the blade surface or it is almost same throughout the blade. This is evident from the same color pattern of temperature contour of blade. In this design there is less chances of formation of thermal cracks. The design of the fan blade remains unchanged throughout the working life of fan. Blade life is increased. Temperature of the output air is same or nearly same as input air. Efficiency increases.

Fig. 12 shows the velocity streamlines of optimized designed fan. By observing the plot, velocity streamlines are uniform which implies that flow is uniform. Required variation in velocity across the blade is achieved. Color of streamlines is almost same across the blade, i.e., at input and output. We get the desired output velocity at output according to the parameters given. As a result of uniform flow, we get lesser or negligible noise and all acoustic problems are solved and hence efficiency is increased.

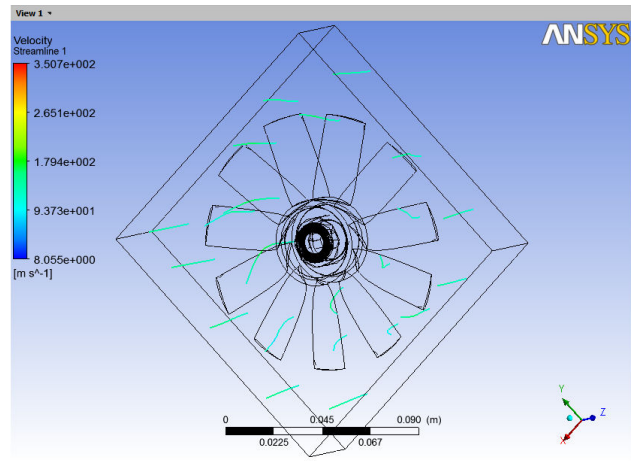

Fig. 12 Velocity streamline of optimized designed fan

IV. CONCLUSION

The results from the numerical simulations provided an insightful understanding of the behavior of fluid flow around an axial fan with different number of fan blades. Numerical CFD analysis was performed for both initially designed and optimized designed axial fan. The numerical CFD results for optimized design were then compared with initially designed axial fan. The key and important outcomes of this study are as follows:

- 1) The CFD modeling shown in this study proved to be very helpful in initiating further and more comprehensive numerical study of the axial fan.
- 2) CFD results were presented in the form of velocity streamlines, which provided actual flow characteristics of air around the fan for different number of fan blades.
- 3) The different parameters like temperature, pressure, fan noise, and turbulence, were also considered while performing CFD analysis. The study revealed that a fan with an optimum number of fan blades performed well as compared to the fan with less number of fan blades. In general, as a compromise between efficiency and cost, five to twelve blades are good practical solutions. Our optimized design is having 11 blades.

ACKNOWLEDGEMENT

The author thanks the management of VIT University for their support and permission to publish this paper. He also expresses gratitude to all of the faculties and lab assistants who contributed to the job design, preparation, and execution of the operation to achieve the results presented in this paper.

REFERENCES

- [1] S. Jain, and Y. Deshpande, "CFD Modeling of a Radiator Axial Fan for Air Flow Distribution," in *World Academy of Science, Engineering and Technology*, Vol : 6 2012-11-28.
- [2] Mahajan Vandana N., Shekhawat Sanjay P., "Analysis of Blades of Axial Flow Fan using Ansys," in *International Journal of Advanced Engineering Technology*, E-ISSN 0976-3945.
- [3] Prof. Jigar S. Patel Prof. Shailesh M. Patel, "Parameter Affecting the Performance of Axial Fan Performance," in *International Journal of*

Engineering Research & Technology (IJERT), Vol. 1 Issue 3, May - 2012 ISSN: 2278-0181.

- [4] Konrad Bamberger, Thomas Carolus, "Optimization of Axial Fans with Highly Swept Blades with Respect to Losses and Noise Reduction," in *University of Siegen*, Paul-Bonatz-Strasse 9-11, 57223 Siegen, Germany.
- [5] Park, J., "A Sound Method for Fan Modeling", *Fluent News*, US, Summer 2005.
- [6] A report on fan design by Moore, 800 s. Missouri avenue Marceline, Missouri.