

Individual Actuators of a Car-Like Robot with Back Trailer

Tarek M. Nazih El-Derini, Ahmed K. El-Shenawy

Abstract—This paper presents the hardware implemented and validation for a special system to assist the unprofessional users of car with back trailers. The system consists of two platforms; the front car platform (C) and the trailer platform (T). The main objective is to control the Trailer platform using the actuators found in the front platform (c). The mobility of the platform (C) is investigated and inverse and forward kinematics model is obtained for both platforms (C) and (T). The system is simulated using Matlab M-file and the simulation examples results illustrated the system performance. The system is constructed with a hardware setup for the front and trailer platform. The hardware experimental results and the simulated examples outputs showed the validation of the hardware setup.

Keywords—Kinematics, Modeling, Wheeled Mobile Robot.

I. INTRODUCTION

DURING the last decade, the automotive industrial countries invested in developing smart cars [1]. Such cars preferred to be semi-automated to help the non-professional drivers in maneuvering and avoiding car accidents [2].

Many surveys were done to determine the severity of these accidents. The national transport commission stated that just in one country (Australia) and in 12 months till April 2011, there were 1334 death on the Australian roads. Also from the economical point of view, the annual cost of road crashes in Australia is about 18 billion dollars [3].

Such trend motivated researchers developing systems to minimize the damage whether in human lives or on the financial side. Many techniques were developed to solve this problem. One of these main problems is collision avoidance. Optimal control techniques as neural network or optimization systems are commonly used for such trend [4], [5].

Civilians nowadays like travelling and camping, so they attach a caravan or an extra luggage to their cars. One of the fatal problems that face them is the maneuvering while driving and parking these trailers. This motivated scientists and researchers to find out a solution to help out the non-professional drivers in maneuvering and parking in small spaces [6], [7].

In [8], [9], the backing control simulated model of a robot with multi-level of trailers using fuzzy controllers is presented.

Implementing an autonomous system that assists the driver during catastrophic incidents and compensate for man error is one of the main aims to minimize accidental rates.

Tarek El-Derini and Ahmed El-Shenawy are with the Electrical and Control Engineering Department, Arab Academy for Science, Technology and Maritime Transport, Alexandria, Egypt (e-mail: tarek.elderini@aast.edu, ahmed.elshenawy@aast.edu).

For example, the main controller of the car with a platform (T) is the platform (C). The classical system nowadays depends on a mechanical differential system between the rear two wheels to minimize the sliding of any of them when the car tries to take a curvature as shown in Fig. 1.

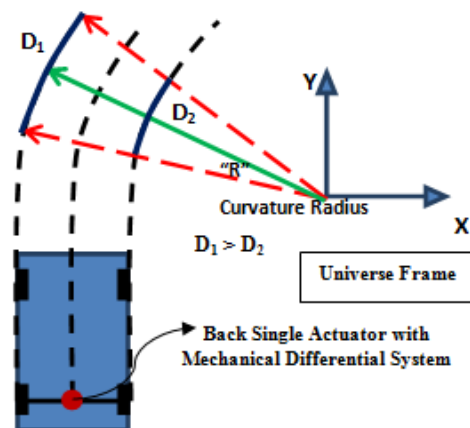

Fig. 1 Differential System with Gears (Front/Rear Wheel Drive)

That is why the new system is proposed. The proposed system depends on an electromechanical solution by removing the coupling part between the two rear wheels and substituting this mechanical system by two actuators; one for each wheel as shown in Fig. 2.

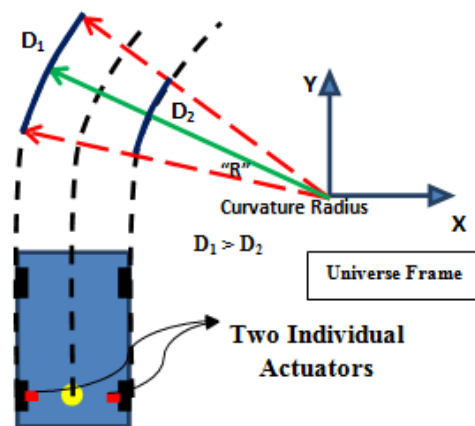

Fig. 2 Individual Wheel Actuated System

The proposed model allows each wheel to have an independent angular velocity; therefore the sliding condition between the two rear wheels does not exist anymore.

II. SYSTEM MODELING

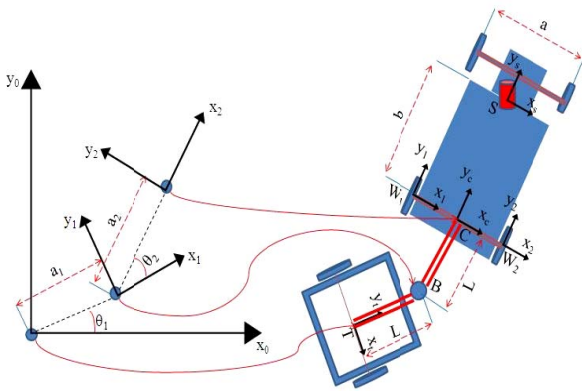

Fig. 3 System Co-ordinates

Modeling the car-like robot (non-holonomic system) mainly is classified into two stages; kinematics modeling and dynamics modeling. The kinematics modeling is considered to be the first step of the dynamics modeling. This paper shows the dynamic modeling only of the proposed system.

The kinematics modeling is divided into two main subsystems which are considered a frame transformation from the robot velocities to the wheels' velocities (Inverse Kinematics) and from the wheels' velocities back to the robot velocities (Forward Kinematics).

There are two forward and inverse kinematics for such kind of robotic system; one for the platform (C) and other for the platform (T). These frame transformations are used to transform the measured wheels' velocities to the robot velocities.

For the platform (C) the forward kinematics matrix is derived using Muir technique [10].

$$\dot{P}_c = J_f \hat{q}_s$$

where \dot{P}_c is the platform (C) velocity in the x-direction, y-direction, and the rotation around z-axis, \hat{q}_s is the platform (C) actuators' measured speeds, and J_f is the Jacobian matrix (Forward Kinematics Solution).

$$J_f = \begin{bmatrix} \frac{2r \sin(2\theta_s)}{-24+a^2(\cos(2\theta_s)-1)} & \frac{2r \sin(2\theta_s)}{-24+a^2(\cos(2\theta_s)-1)} & -\frac{4b(1+\cos(2\theta_s))}{-24+a^2(\cos(2\theta_s)-1)} \\ \frac{2r(5+\cos(2\theta_s))}{-24+a^2(\cos(2\theta_s)-1)} & \frac{2r(5+\cos(2\theta_s))}{-24+a^2(\cos(2\theta_s)-1)} & -\frac{b(4+a^2)(\sin(2\theta_s))}{-24+a^2(\cos(2\theta_s)-1)} \\ -\frac{2ar}{3a^2+4} & \frac{2ar}{3a^2+4} & \frac{4+a^2}{3a^2+4} \end{bmatrix} \quad (1)$$

Similarly for the inverse kinematics for platform (C), the inverse solution model is derived by Muir technique, but, this time the frame transformation is from the robot velocities to the actuators' velocities.

$$\hat{q}_{asol} = J_{inn} \dot{P}_c$$

$$J_{inn} = \begin{bmatrix} \frac{abc \sin^2(\theta_s)}{2r(b^2 \cos^2(\theta_s)+1)} & \frac{abs \sin(\theta_s) \cos(\theta_s)}{2r(b^2 \cos^2(\theta_s)+1)} & \frac{a}{2r(b^2 \cos^2(\theta_s)+1)} \\ \frac{-abc \cos^2(\theta_s)}{2r(b^2 \cos^2(\theta_s)+1)} & \frac{-abs \sin(\theta_s) \cos(\theta_s)}{2r(b^2 \cos^2(\theta_s)+1)} & -\frac{a}{2r(b^2 \cos^2(\theta_s)+1)} \\ \frac{bc \cos^2(\theta_s)}{b^2 \cos^2(\theta_s)+1} & \frac{bs \sin(\theta_s) \cos(\theta_s)}{b^2 \cos^2(\theta_s)+1} & \frac{1}{b^2 \cos^2(\theta_s)+1} \end{bmatrix} + \begin{bmatrix} \frac{\sin(\theta_s)}{r} & \frac{\cos(\theta_s)}{r} & \frac{a}{2r} \\ \frac{\sin(\theta_s)}{r} & \frac{\cos(\theta_s)}{r} & -\frac{a}{2r} \\ 0 & 0 & 0 \end{bmatrix} \quad (2)$$

where " J_{inn} " is the modified Jacobian for solving the singularities of the three castor wheeled robot and proved its efficient performance [11] in reducing the energy consumption of the robot, i.e. the inverse kinematics matrix.

While the kinematic model of platform (T) is considered to be a two linked manipulated robotic system as there are no actuators or sensors on this platform or on the link between the two platforms as shown in Fig. 3.

The distance L between the points (T) and (B) (the co-ordinates of platform (T) and the steering joint between the two platforms) is considered to be the first link with the steering angle (θ_1). The second link is the distance between the steering joint (B) and Platform (C) steering point (S), which is equal to $(L+b)$ with a steering angle (θ_2). The total distance between the point (T) and the point (S) is equal to (L) with a steering angle (θ_t).

The analysis of this type of system can be done by the trigonometric function using the transformation and the rotation of the co-ordinates only.

For example, considering the point (T) is the first point, the joint (B) is the second point, and the point (S) is the third point. What is required is to move the point (T) from the origin to reach the point (S) co-ordinates by means of rotating and translation of point (T) co-ordinates as shown in Fig. 3 where the point(S) is the reference co-ordinates parallel to the floor co-ordinates.

The inverse and forward kinematics of such technique is quiet known by many two linked manipulated robots and used many times before.

The position angles (θ_1, θ_2) are calculated from the trailer co-ordinates (point (T)) and the joint co-ordinates (point (B)) from the inverse kinematics of the trailer given by [12]. Since

$$L_1 = L_2 = L$$

$$\theta_2 = \tan^{-1} \left(\frac{\sqrt{2L(L+b) - (X_s^2 + Y_s^2)}}{X_s^2 + Y_s^2} \right) \quad (3)$$

$$\theta_1 = \tan^{-1}(Y_s, X_s) - \tan^{-1}(L \sin(\theta_2), (L + (L + b)) \cos(\theta_2)) \quad (4)$$

where (Y_s and X_s) are the positions of the Platform (C) steering co-ordinates. They are calculated from the forward kinematics of the trailer given by [12].

$$P_T = R_T P_S$$

$$R_T = \begin{bmatrix} \cos(\theta_t) & -\sin(\theta_t) & 0 & L \cos(\theta_1) + (L + b) \cos(\theta_2) \\ \sin(\theta_t) & \cos(\theta_t) & 0 & L \sin(\theta_1) + (L + b) \sin(\theta_2) \\ 0 & 0 & 1 & 0 \\ 0 & 0 & 0 & 1 \end{bmatrix} \quad (5)$$

where P_T is the position co-ordinates of platform (T) and P_S is the position co-ordinates of Platform (C) steering point (S), and (θ_t) is angle between the two co-ordinates.

$$\theta_t = \theta_1 + \theta_2 \quad (6)$$

$$P_C = R_S P_S$$

$$R_T = \begin{bmatrix} \cos(\theta_2) & -\sin(\theta_2) & 0 & b\cos(\theta_2) \\ \sin(\theta_2) & \cos(\theta_2) & 0 & b\sin(\theta_2) \\ 0 & 0 & 1 & 0 \\ 0 & 0 & 0 & 1 \end{bmatrix} \quad (7)$$

where P_C is the position co-ordinates of platform (C) and P_S is the position co-ordinates of platform (C) steering point (S).

III. HARDWARE IMPLEMENTATION

This section studies the construction of the system whether mechanically or electrically, and the integration of these two stages to deliver the hardware setup by which the system is validated with respect to the developed theories in this paper.

A. Mechanical Construction

This section explains in detail the mechanical construction of both platforms (C and T), the system is divided into three main parts, the front car (platform (C)), the back trailer (platform (T)), and the link between the two platforms as shown in Fig. 4.



Fig. 4 Real Hardware Implementation

1. Platform (C)

The front car has two rear motors responsible for the car motion and a steering motor for changing the direction of motion. The rear motors are fixed to the body and connected directly to the rear wheels, while the steering motor is fixed to the body and connected to the steering wheels through a mechanical transmission system as shown in Fig. 4.

2. Platform (T)

The back trailer is an aluminum box with a rod connected to two conventional wheels without any actuators; the wheels are at one third of the trailers back as shown in Fig. 4.

By this the mechanical construction section is completed and the electrical hardware elements should be identified.

B. Electrical Elements

All the actuating elements are connected to the front car only, while the sensing ones might be connected to both the front car and the trailer just to measure the position of both platforms. The electrical hardware elements connected to the front car and the trailer and their functions as shown in Fig. 5.

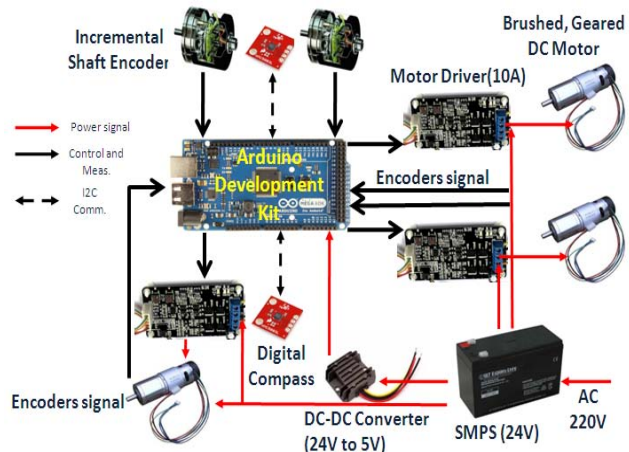

Fig. 5 Electrical Hardware Elements

IV. CONTROL MODEL

The output of the platform (T) inverse kinematics is considered to be the set-point for platform (C) (\dot{P}_C). The rotation angular velocity ($\dot{\theta}_{zr}$) is integrated, and then used in calculating the new steering angle (θ_s) after being compared to the integration of the measured rotation angular velocity ($\dot{\theta}_{zm}$).

When (\dot{P}_C) is subjected to the inverse kinematics of platform (C), frame transformation between the robot velocities and the wheels' speeds is done to get the new reference wheels' speeds (\dot{q}_a) that are compared to the measured wheels' speeds (\dot{q}_s), then subjected to the motor model with the PI-controller.

The measured wheels' speeds (\dot{q}_s) then are subjected to the forward kinematics of platform (C) forming a new frame transformation to get the robot measured velocities (\dot{P}_{cm}). The new robot measured velocities are subjected to the forward kinematics of platform (T), getting the platform (T) new measured velocities (\dot{P}_{tm}) that are integrated and compared to the Trajectory Positions Reference as shown in Fig. 6.

V. SIMULATION & PRACTICAL RESULTS

This section of the paper shows the performance of the control system developed for platform (T) by applying two different position trajectories; a constant position input and a variable position input. The first example is represented by the input values of a fixed position in the X-direction. This reference positions should make the platform (T) follow platform (C) for a trajectory path in X-direction Fig. 7.

shown in Fig. 10, which represents a motion in the four quadrants of the platform (C) Cartesian plane starting with a negative motion in the X-direction.

For the experimental results, the second experiment is represented by a variable position input. This reference positions should make both platforms (C and T) follow a trajectory of a circular path Figs. 11 (a), (b) which represents a motion in the four quadrants of the platform (C) Cartesian plane starting with a negative motion in the X-direction.

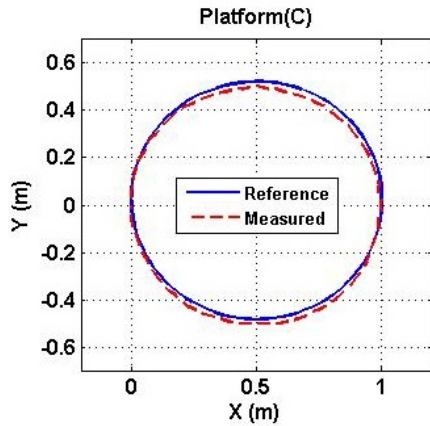

Fig. 11 (a) Platform (C) Trajectory

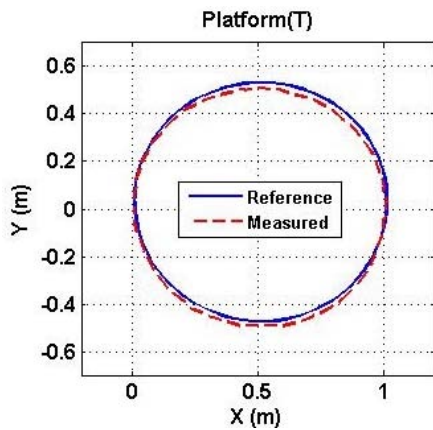

Fig. 11 (b) Platform (T) Trajectory

Figs. 11 (a), (b) show the platform (C) and platform (T) positions fluctuate from zero to maximum until both platforms' (C and T) positions in the X-direction are horizontal (perpendicular to the Y-axis), then starts decreasing until both platforms' (C and T) positions in the X-direction are vertical (parallel to the Y-axis). Then from zero to minimum until both platforms' (C and T) positions in the X-direction are horizontal (perpendicular to the Y-axis), then starts decreasing until both platforms' (C and T) positions in the X-direction are vertical (parallel to the Y-axis) as both velocities in X-direction and Y-direction fluctuates forming the circular path shown in Figs. 12 (a), (b).

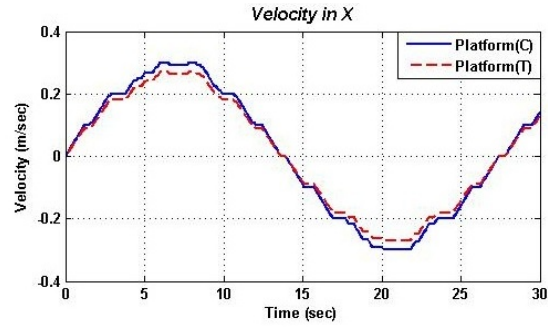

Fig. 12 (a) Platform (C) Measured Velocity

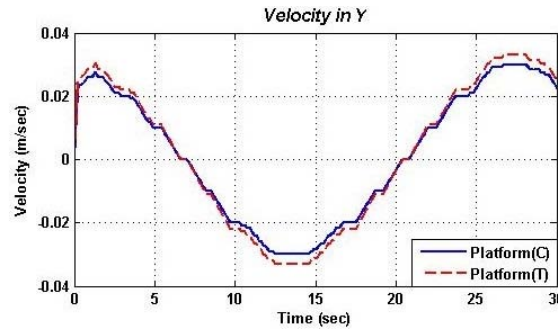

Fig. 12 (b) Platform (T) Measured Velocity

It is obvious from Fig. 13 that the P-controller effect is effective such that the error shown is within the accepted range of error (2% – 5%).

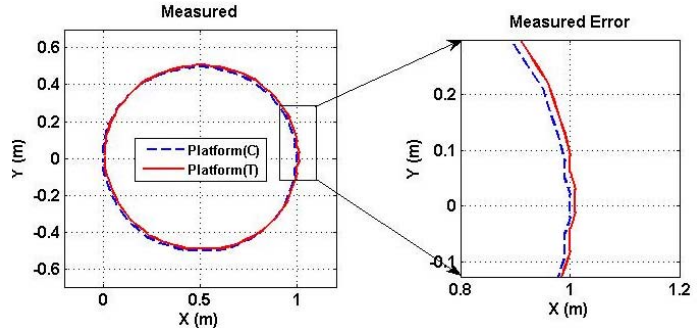

Fig. 13 Platform (C) and Platform (T) Measured Trajectories

VI. CONCLUSIONS

A control system for a car like wheeled mobile robot with a back trailer is proposed in this paper. The system consists of two platforms; the front car platform (C) and the trailer platform (T). The main objective is to control the trailer platform using the actuators found in the front platform(C). The inverse kinematics is modified to solve the singularity problem due to the conventional wheels' constraints (non-holonomic constraints – sliding in the X-direction).

The control technique used was divided into three stages; firstly an axes level control for actuators to insure the performance of the wheels' velocities. Secondly, a controller based kinematics is established on the front platform(C).

Thirdly, a trajectory control for the trailer trajectory uses proportional controller. Consequently, the hardware implementation of the proposed was established and validated. The experimental results showed efficient response with acceptable trajectory errors.

REFERENCES

- [1] O. Daniel Gott, "The Smart Car Project: A case Study in Computer-Mediated Control," Faculty of the Graduate School of State University of New York at Buffalo in partial, 2003.
- [2] A Corporate Approach to Transport Safety, Discussion Paper, August 2011.
- [3] ATC (2011) National Road Safety Strategy 2011-2020.
- [4] Herbert G. Tanner, "Non-holonomic Stabilization with Collision Avoidance for Mobile Robots", 2001 IEEE/RSJ, International Conference on Intelligent Robots and Systems, Maui, Hawaii, USA, 2001.
- [5] Ullah, Q., "Integrated collision avoidance and tracking system for mobile robot", Robotics and Artificial Intelligence (ICRAI), International Conference on 2012.
- [6] Dawn Tiibury, "Trajectory Generation for the N-Trailer Problem Using Goursat Normal Form" In Transaction on automatic Control, VOL. 40, NO. 5, MAY 1995.
- [7] Tom Airaksinen, "Automatic Parallel Parking Assistance System User Interface Design Easier Said Than Done", Technical Description, 2004.
- [8] K. Tanaka, "Backing control problem of a mobile robot with multiple trailers: fuzzy modeling and LMI-based design ", IEEE Transactions on Systems Man and Cybernetics Part C, 1998.
- [9] G. Siamantas, "Backing-up Fuzzy Control of a Truck-trailer Equipped with a Kingpin Sliding Mechanism", IFIP International Federation for Information Processing Volume 296, 2009.
- [10] P. Muir. "Modeling and control of wheeled mobile robots," PhD dissertation Carnegie Mellon university, 1987
- [11] Ahmed K. El-Shenawy, Tarek M. N. El-Derini, "Solving The Singularity of Car Like Robot With Back Trailer", 22nd International Conference on Computer Theory and Applications, 2012.
- [12] Serdar Kucuk, "Robot Kinematics: Forward and Inverse Kinematics" Handbook of Industrial Robotics: Theory, Modeling and Control, Dec 2006.



Tarek M. Nazih El-Derini has received his M.Sc. degree in December 2013 within the field of robotics systems from the Arab Academy for Science, Technology & Maritime Transport (AASTMT), Alexandria, Egypt. In addition to his B.Sc. degree in Electrical and Control Engineering from the Arab academy for Science, Technology & Maritime Transport (AASTMT), Alexandria, Egypt in 2009. Currently, he is a Teacher/Lecturer Assistant at Electrical and Control Engineering Department at the Arab Academy for Science, Technology & Maritime Transport (AASTMT). His research interests are wheeled mobile robots, manipulator robotics systems.



Ahmed K. El-Shenawy has received his doctoral degree in April 2010 as Dr.rar,nat, Doctor of Natural Science in the field of robotics systems from University of Mannheim, in Germany. In addition to his the B.Sc. and M.Sc. degrees in Electrical and Control Engineering from the Arab academy for Science, Technology & Maritime Transport (AASTMT), Alexandria, Egypt in 1999 and 2002, respectively. Currently, he is an Assistant Professor at Electrical and Control Engineering Department at the Arab Academy for Science, Technology & Maritime Transport (AASTMT). His research interests are wheeled mobile robots, manipulator robotics systems and medical robotics.