

Multicasting Characteristics of All-Optical Triode Based On Negative Feedback Semiconductor Optical Amplifiers

S. Aisyah Azizan, M. Syafiq Azmi, Yuki Harada, Yoshinobu Maeda, Takaomi Matsutani

Abstract—We introduced an all-optical multicasting characteristics with wavelength conversion based on a novel all-optical triode using negative feedback semiconductor optical amplifier. This study was demonstrated with a transfer speed of 10 Gb/s to a non-return zero $2^{31}-1$ pseudorandom bit sequence system. This multi-wavelength converter device can simultaneously provide three channels of output signal with the support of non-inverted and inverted conversion. We studied that an all-optical multicasting and wavelength conversion accomplishing cross gain modulation is effective in a semiconductor optical amplifier which is effective to provide an inverted conversion thus negative feedback. The relationship of received power of back to back signal and output signals with wavelength 1535 nm, 1540 nm, 1545 nm, 1550 nm, and 1555 nm with bit error rate was investigated. It was reported that the output signal wavelengths were successfully converted and modulated with a power penalty of less than 8.7 dB, which the highest is 8.6 dB while the lowest is 4.4 dB. It was proved that all-optical multicasting and wavelength conversion using an optical triode with a negative feedback by three channels at the same time at a speed of 10 Gb/s is a promising device for the new wavelength conversion technology.

Keywords—Cross gain modulation, multicasting, negative feedback optical amplifier, semiconductor optical amplifier.

I. INTRODUCTION

WAVELENGTH division multiplexing (WDM) has a high demand in wider band as it has progressed nowadays. This demand is especially significant for the future technology of photonic networks.

As the cost and power consumption of WDM network nodes are in a large amount, it is essential to discard the conventional optical/electrical/optical (O/E/O) to optical/optical (O/O) by using all-optical wavelength converter device. Optical wavelength conversion is anticipated to be an essential function for the emerging bandwidth-intensive applications (video conferencing, video-on-demand services etc.) of high speed WDM optical networks by enabling rapid resolution of output-port contention and wavelength reuse [1].

S. Aisyah Azizan is studying in Kinki University, 3-4-1 Kowakae, Higashi Osaka, 577-8502 Japan. She is now with the Graduate School of Science and Engineering, Optoelectronics Laboratory (phone: +81-80-4391-1806; e-mail: 1333340437w@kindai.ac.jp).

M. Syafiq Azmi and Yuki Harada are studying in Kinki University, 3-4-1 Kowakae, Higashi Osaka, 577-8502 Japan (e-mail: 1333340414b@kindai.ac.jp, 1433340437c@kindai.ac.jp, respectively).

Yoshinobu Maeda is with the Kinki University, 3-4-1 Kowakae, Higashi Osaka, 577-8502 Japan (phone: +81-6-6730-5880 ext. 4238; e-mail: ymaeda@ele.kindai.ac.jp).

Takaomi Matsutani is with the Kinki University, 3-4-1 Kowakae, Higashi Osaka, 577-8502 Japan (phone: +81-6-6721-2332 ext. 4565; e-mail: matutani@ele.kindai.ac.jp).

All-optical signal processing is expected to have a wide application in communication and computing. This is due to its capability of handling large bandwidth signals and large information flows. Basic functions such as de-multiplexing and switching can be achieved by using all-optical gates, which are realized by optical nonlinearities in semiconductor materials.

In addition, all-optical wavelength converter becomes a key functional element in WDM optical network due to its capabilities of transparent interoperability, contention resolution, wavelength routing, and in general, better utilization of the fixed set of wavelengths [2].

Nowadays, multicasting is a potentially useful networking function that involves the same data stream from a single node to several destinations nodes. This network is also called as photonic network. Photonic network is commonly enforced via Internet protocol (IP) digital routers in electrical domain. Photonic network effectiveness will be encouraged when the multicasting can be performed all-optically. The optical routers will be able to multicast an input signal to different wavelengths.

There is bulk of wavelength conversion and multicasting techniques that have been proposed so far. The techniques include a nonlinear semiconductor optical amplifier (SOA) based interferometer, an injection locking of a Fabry-Perot laser [3], and SOA with cross gain modulation (XGM) or SOA with cross phase modulation (XPM) [4].

In this paper, we investigated the new wavelength converter technology technique based on the negative feedback optical amplification effect of SOA. The use of negative feedback optical amplification shows great potential in three areas: improvement of output modulation degree, reduction of wave distortion and a more stable baseline [5]. This will result an output signal whose gain, waveform, and, baseline which stabilized automatically. Wavelength conversion and switching characteristics was investigated by introducing a control light together with input signal light [6].

The optical amplifier consists of an InGaAsP/InP SOA and an optical add/drop filter. It is equipped with a negative feedback function. In the negative feedback SOA, the output modulation degree will be substantially higher and the distortion of the waveform was extremely small in wide input signal [7]. We demonstrated the conversion wavelength by using two SOAs based on optical triode, and measured the bit error rate (BER) characteristics for each wavelength. As a result, this device has been realized that all-optical multicasting and wavelength conversion by using 1 to 3 channels at the speed of 10 Gb/s at the same time is possible.

Negative feedback optical amplifier consists of a SOA and an optical add/drop filter. The basic theory of negative feedback is explained as follows.

SOA is structured based on the ridge waveguide of InGaAsP/InP material. The composition of the InGaAsP active layer is chosen to have gain peak wavelength around 1550 nm. The maximum small signal fiber to fiber gain is around 15 dB and the output saturation power is approximately 2 mW measured at 1550 nm with a bias current of 250 mA [7]. Fig. 1 shows the diagram of a negative feedback SOA circuit.

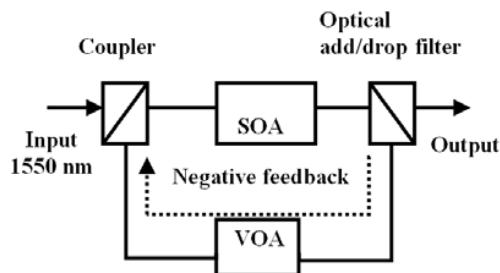

Fig. 1 Block diagram of a negative feedback SOA, VOA: Variable optical attenuator

As shown in Fig. 1, a wavelength of 1550 nm is set as an input signal by a tunable laser then is modulated by the mean of electro-optic modulator. The modulated input signal is fed into the SOA by using a coupler. An optical add/drop filter is located in order to extract an output signal light of the wavelength 1550 nm. The XGM mechanism in SOA will provide the spontaneous emission contain an inverted replica of the information carried by input signal. The inverted replica information is fed back and injected together with the input signal back into the SOA by using a coupler.

The output average power was around 6.4 mW, which the SOA was without negative feedback while in the SOA with negative feedback; the output average power was approximately 1.9 mW. These were experimented when the negative feedback average power was 0.12 mW [7].

Fig. 2 shows the concept diagram of a negative feedback optical amplification effect. The straight-line represents the case where the SOA was used with negative feedback while the dotted line represents the case of the SOA without negative feedback.

Figs. 2 (a), (b), and (c) show the waveforms of the input signal, the negative feedback, and the gain in SOA respectively. In the SOA that has a XGM mechanism, spontaneous emission lights, which have wavelengths near a wavelength λ_1 , the input signal have an intensity varying in response to a variation in the intensity of that input signal. Characteristically, the intensity variation of the spontaneous emission lights are inverted with respect to the variation in the input signal then the spontaneous emission lights are outputted from the SOA as reported in Fig. 2 (b).

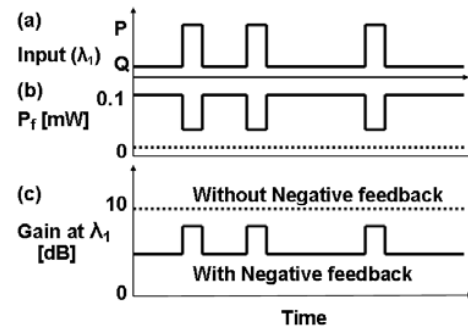

Fig. 2 Concept diagram of negative feedback optical amplification effect

In the past, it is common that the spontaneous emission lights as well as the surrounding light that have wavelengths other than the wavelength λ_1 are removed by a band pass filter, since it becomes a factor of noise generation [7]. In this situation, a negative feedback optical signal amplification phenomenon in which characteristics of the gain of the SOA is drastically changed by feeding back the separated surrounding light to the SOA so that the gain is modulated as shown in Fig. 2 (c).

Therefore, noise reduction is realized all-optically with a negative feedback SOA. It can be concluded that the output signal waveform is exceptionally improved over that without negative feedback. In addition, the baseline of the output signal waveform is suppressed because the gain in the SOA is low when the power of input signal is at the low logical level, whereas the output signal is stressed because of the high SOA gain when the input signal power is high as shown in Fig. 2 [7]. In this paper, we created an all-optical triode based on the negative feedback SOA theory.

II. OPERATION PRINCIPLE

Fig. 3 is the schematic illustration of the experimental setup of this study. The operating circuit of negative feedback optical amplification by using optical triode is explained as follows. In this experiment, we structured an optical triode by using two SOAs forming two stages of SOAs, which are SOA-1 for the first stage and SOA-2 for the second stage of the circuit with an optical add/drop filter (1550 nm \pm 6.5 nm) and a 1 \times 4 waveguide coupler unit.

An optical signal that has been modulated by the external optical modulator (O.M.) enters the SOA-1 via an optical add/drop filter (1550 nm \pm 6.5 nm). Due to the XGM mechanism in SOA-1, the probe light, which is set in the SOA-1, is modulated into an input signal then provide the spontaneous emission contain an inverted intensity to the optical signal which fed in SOA-1. This inverted optical signal then passes through a 1x4 waveguide coupler unit thenceforth it flowed into the SOA-2 based on the negative feedback theory. The input signal is amplified with gain modulation by inverted optical signal in the SOA-2.

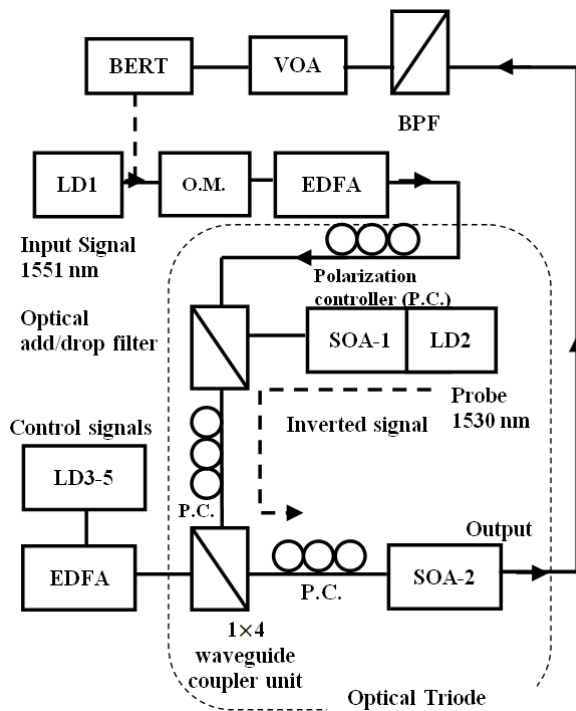

Fig. 3 Experimental setup

In this research, an optical signal with wavelength 1551 nm is set by a laser source (also called as LD1) as the input signal. This optical signal is modulated to a non-return zero (NRZ) $2^{31}-1$ pseudorandom bit sequence (PRBS) with a transfer speed of 10 Gb/s by the O.M. then is amplified by the Erbium doped fiber amplifier (EDFA) before being fed into the optical triode. Additionally, probe light with wavelength of 1530 nm is set in SOA-1 for the wavelength conversion to produce an inverted signal.

In order to perform multicasting in wavelength conversion through this experiment, three different wavelengths are set as the control signal in SOA-2. Five different wavelengths are chosen as the control signal to be used in this research. They are set by laser sources (LD3-5) each as 1535 nm, 1540 nm, 1545 nm, 1550 nm, and 1555 nm. These control signals (three wavelengths at a time) will be fed into the SOA-2 via 1×4 waveguide coupler unit. Optical signal from the SOA-1, which has undergone XGM will be joined together with the control signals and wavelength conversion will be occurred. Consequently, the three different optical signals will be amplified by the SOA-2 thus the optical signals passed a band pass filter (BPF) and VOA as the output signals.

As the three control signals are in different wavelengths, a BPF is needed for wavelength separation to recognize the output signals. Thenceforth, the optical signals are inserted into the bit error rate tester (BERT) hence the relationship of received power of back to back signal (B to B signal/BER of input signal) and output signals which is controlled by the VOA, with BER is measured.

III. RESULTS AND DISCUSSION

Eye diagrams of output signals are observed by oscilloscope in this experiment. Fig. 4 (a) reported the input signal eye diagram whereas (b), (c), (d), (e), and (f) show the eye diagram for output signals of 1535 nm, 1540 nm, 1545 nm, 1550 nm, and 1555 nm respectively. The eye diagram of input and output signals are recorded when their average power is $150 \mu\text{W}$ except for the 1555 nm is recorded when the average power is $200 \mu\text{W}$. This is due to the very small output power of the signal. Zero level from baseline (from ground) of input signal is $37 \mu\text{W}$. Eye aperture, extinction ratio and zero level from the baseline of each output signal eye diagrams are measured and are summarized in Table I.

As reported in Fig. 4, the baseline of output signal eye diagrams arose gradually from 1535 nm to 1555 nm compared to the input signal eye diagram. Based on Table I, the zero level from baseline of output signals increases when the wavelength becomes longer, from 1535 nm to 1555 nm. However it becomes smaller when the wavelength is 1550 nm. However, as shown in Figs. 4 (e) and (f), their zero level decrease and the distortion of the eye diagrams can be seen clearly. Fig. 4 (f) shows that the eye of the signal is slightly bent to the right when it changes from 0 level to 1 level. In addition, the degradation in eye aperture of output signals is reported in Fig. 4 and Table I. The obtained results show that, the highest extinction ratio is 4.11 dB when the output signal wavelength is 1535 nm, which is 38.1% smaller than the input signal (10.8 dB).

Based on the reported results, an all-optical wavelength conversion has such successfully been demonstrated with SOAs that exploit XGM as same as the XPM effect and is a promising device. However, the consumption of large amount of power and noise has been found and proved due to the distortion of the eye diagrams shown in Fig. 4 especially in Figs. 4 (e) and (f).

In spite of all, it is understood that the eye aperture of optical signals declines as the wavelength increases. In Fig. 4, we conclude that 1535 nm has the highest eye aperture compared to the other output signals.

In order to assess multicasting characteristics, we measured the relationship between received power and BER; reported in Fig. 5. We have measured the BER for B to B signal (also called back to back signal), output signals 1535 nm, 1540 nm, 1545 nm, 1550 nm, and 1555 nm respectively.

It was found that the smaller the received power of the signals, the bigger the BER will be. Also, we found out that the error of longer wavelength signals started to happen earlier than the shorter wavelength signals. We studied that it may be an effect of the dependence of the speed propagation light through the medium during the conversion of wavelengths that produce errors. From the result of BER test, relationship of power penalty with respect to B to B and control signals when the BER is 10^{-9} is summarized. The summarization result is shown in Fig. 6.

TABLE I
SUMMARIZATION OF MEASUREMENT RESULT

Wavelength [nm]	Eye aperture [dB]	Extinction ratio [dB]	Zero level [μ W]
1535	2.72	4.11	59
1540	1.93	3.45	73
1545	1.90	3.41	75
1550	1.78	3.35	69
1555	1.46	2.95	81

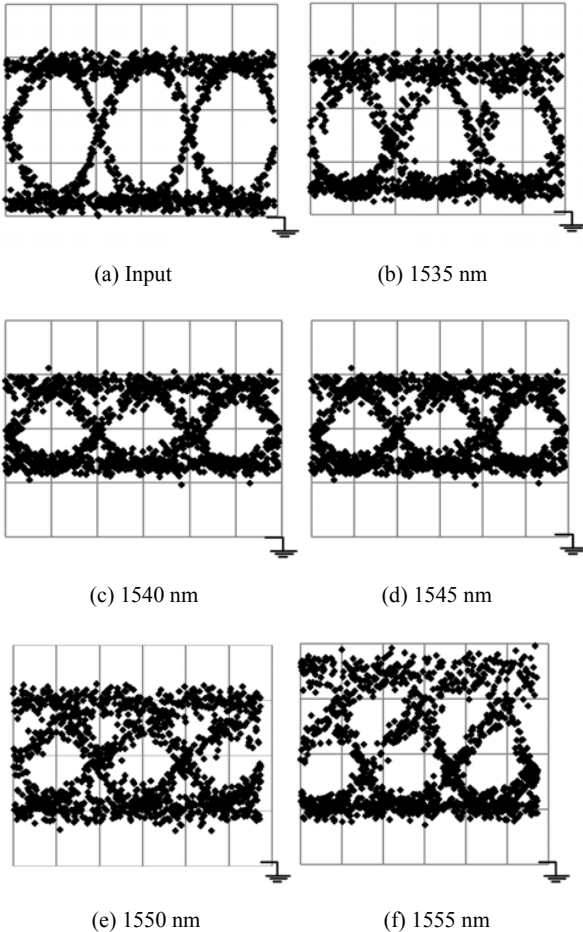

Fig. 4 Eye diagrams of input and output signals (50 μ W/div, 50ps/div)

It is understood that the BER and power penalty with respect to B to B signal become worse as the control signal wavelengths increase. Fig. 6 reported that we obtained power penalty that less than 8.7 dB which we believe that still can be improved next in our work. The highest power penalty is 8.6 dB when the control signal is 1555 nm while the lowest is 4.4 dB when the control signal is 1535 nm. Therefore, we found that BER for output wavelength of 1535 nm is the nearest to the B to B signal than output wavelengths of 1540 nm, 1545 nm, 1550 nm, and 1555 nm.

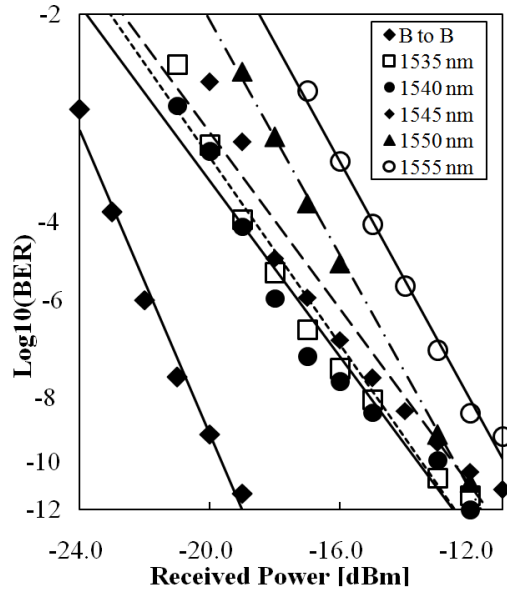

Fig. 5 Result of bit error rate test

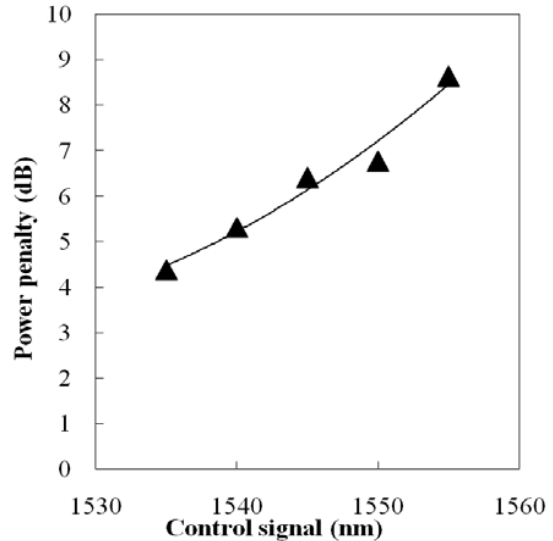

Fig. 6 Relationship of power penalty with respect to B to B and control signal

We understood that a conventional optical amplifier merely has a simple amplification function that is almost constant gain. Also, the amplifier disadvantageously amplifies not only the signal but also the noise. Therefore, the eye diagram and baseline of the output signal cannot be improved basically in relation with the noise, thereby making difficult to achieve an advanced signal processing.

The expansion of the number of output signals and improvement of results could follow this work, in the near future. Moreover, the proposed of all-optical multicasting and wavelength conversion can simultaneously provide multiple output signals which have same information but different wavelengths. Therefore, it can be applied to embodying

multicasting functions in the WDM network. Nevertheless, we need to improve in terms of structure of our optical triode and the experimental setup for the next work.

IV. CONCLUSION

We investigated the multicasting characteristics by using an optical triode, which has been set up with two stages of SOAs that constitute a negative feedback optical amplifier with an optical add/drop filter and a 1×4 waveguide coupler unit. Based on the BER measurement result, output signal of 1535 nm produced the least error compared to the other output signals after undergone wavelength conversion.

Although the BER and power penalty obtained by our optical triode are still need improvements, we thereby concluded that 1535 nm has the smallest power penalty than the other output signals when the BER is 10^{-9} . Therefore, we understood that when the wavelength becomes longer, the BER becomes worse. Hence, this device also proved that all-optical multicasting and wavelength conversion with three channels at a time with a transfer speed of 10 Gb/s is possible. The proposed scheme can be used for multicasting and wavelength conversion of optical data in a core node of a WDM network due to the simple and cost effective configuration of optical triode.

Furthermore, we found out that, by this experiment, it is possible to achieve negative feedback optical amplification by SOA with the insertion of input and control signal into the SOA. It also proved that the conversion of wavelength (O/E/O) through electronic circuit can be innovated to all-optical signals (O/O) and are applicable in our optical triode.

Multicasting characteristics are recognized and the conversion of one wavelength to another different wavelength by injecting input and control signal with a speed of 10 Gb/s at the same time in this device has been proved.

ACKNOWLEDGMENT

This work was supported in part by the Ministry of Education, Culture, Science and Technology of Japan, a Grant-in-Aid (21560048) for scientific research ©.

REFERENCES

- [1] Y. Yuang et al., Nonblocking WDM multicast switching networks, IEEE Trans On Parallel and Distrib. Sys., pp. 1274-1287, 2000.
- [2] J. M. H. Elmighani and H. T. Mouftah, All-optical wavelength conversion: Technologies and applications in DWDM networks, IEEE Commun. Mag., vol. 38, pp. 86-92, March 2000.
- [3] C. W. Chow et al., 8×10 Gb/s multiwavelength injection locking of a FP laser diode for WDM multicast, Proc. Of IEEE LEOS, pp. 682-683, 2003.
- [4] M. Matsuura, N. Kishi, and T. Miki, Broadband regenerative wavelength conversion and multicasting using triple-stage semiconductor-based wavelength converters, IEEE Photon. Technol. Lett., pp. 2659, 2006.
- [5] Yoshinobu Maeda and Masakazu Takagi, Negative Feedback Semiconductor Optical Amplifier Using Fiber Bragg Gratings, The 15th Microoptics Conference (MOC'09), Tokyo, Japan, Oct. 25-28, 2009, pp. 290.
- [6] Y. Maeda and L. Occhi, All-optical triode based on a tandem wavelength converter using reflective semiconductor optical amplifiers, IEEE Photonics. Technol. Lett., pp. 257, 2003.
- [7] Y. Maeda, Advances in Optical Amplifiers, Paul Urquhart ed. INTECH Open Access, pp. 231-252, 2011.