

The Nuclear Power Plant Environment Monitoring System through Mobile Units

P. Tanuska, A. Elias, P. Vazan, B. Zahradnikova

Abstract—This article describes the information system for measuring and evaluating the dose rate in the environment of nuclear power plants Mochovce and Bohunice in Slovakia.

The article presents the results achieved in the implementation of the EU project – Research of monitoring and evaluation of non-standard conditions in the area of nuclear power plants. The objectives included improving the system of acquisition, measuring and evaluating data with mobile and autonomous units applying new knowledge from research.

The article provides basic and specific features of the system and compared to the previous version of the system, also new functions.

Keywords—Information system, dose rate, mobile devices, nuclear power plant.

I. INTRODUCTION

THE purpose of measuring the dose rate using monitoring devices is to detect the radiation situation in nuclear power plants (Bohunice and Mochovce of the SE-ENEL company) in various stages of monitoring emergency situations.

Dose rate is calculated as the ratio of rate dD in the time interval dt , and this interval [2], [3]:

$$\dot{D} = \frac{dD}{dt} [Gy.s^{-1}] \quad (1)$$

At a given point, a dose (an absorbed dose) D is specified as the ratio of the medium energy transmitted $d\varepsilon$, transferred to a substance with the weight dm by inducing ionizing radiation.

$$D = \frac{d\varepsilon}{dm} [Gy] \quad (2)$$

where ε is the transferred energy and is calculated as the sum of the differences $(R_{in}-R_{ex})$ and $(Q_{in}-Q_{ex})$, where R represents radiated energy of each charged and uncharged ionizing particle, which entered (R_{in}) and left (R_{ex}) a substance in the given space (body), Q_{in} is a loss and Q_{ex} stands for an increase in resting nuclear energy and in elementary particles in any nuclear transform in the space.

This publication is the result of implementation of the project: “Research of monitoring and evaluation of non-standard conditions in the area of nuclear power plants” (ITMS: 26220220159) supported by the Research & Development Operational Programme funded by the ERDF.

P. Tanuska is with the Slovak University of Technology in Bratislava, Faculty of Material Science and Technology in Trnava (phone: +421918646061; e-mail: pavol.tanuska@stuba.sk).

A. Elias, P. Vazan and B. Zahradnikova are with the Slovak University of Technology in Bratislava, Faculty of Material Science and Technology in Trnava (e-mail: andrej.elias@stuba.sk, pavel.vazan@stuba.sk).

$$\varepsilon = (R_{in} - R_{ex}) + (Q_{in} - Q_{ex}) [J] \quad (3)$$

Currently, there is no universal and open system for data collection and assessing risk data (clearly including dose rate) in the region of Central Europe [6]. Based on long cooperation with a number of companies, such as SE-ENEL a.s., Research Institute of nuclear power plants and other, the need to build systems for monitoring environment was identified, with an emphasis being laid on the identification of pollution caused by radioactive waste. The implementation of a complex research in this area is a prerequisite for improving the situation.

Improving the system for acquisition, measurement and evaluation of system data using mobile units was one of the objectives of this research.

II. PROPOSAL OF THE SYSTEM

System monitoring dose rate (hereinafter referred to as GISmon system) is one of technical systems supporting decision-making in emergency situations. The structure of technical resources for monitoring radiation situation in the environment of the Jaslovské Bohunice Nuclear Power Plant is in Fig. 1.

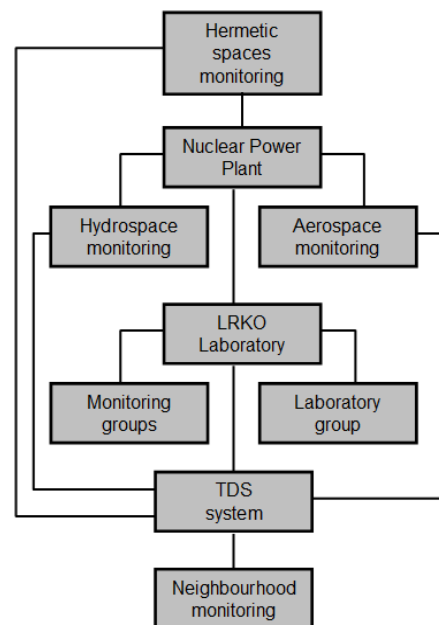

Fig. 1 Technical means for monitoring radiation situation [1]

The GISmon system should be seen as an expansion component of the information system TDS – teledosimetric system [4]. Monitoring of any physical quantity can be achieved by hardware reconfiguration of the system. It depends on the sensors used.

The GISmon system, whose structure is captured in Fig. 2, consists of three basic modules. GISmon Vehicle is an application running on a computer in a car. GISmon Desktop is an application running on computers in a control room. GISmon Server is an application running on the server.

System GISmon Desktop is used to display data from mobile units equipped with the GISmon Vehicle system and to provide any further communication with these units. The GISmon system is a GIS application (geographic information system) allowing using both vector and raster maps. The system supports importing and further using vector base such as ArcView Shapefile or MapInfo MIF/MID and more. It is also possible to georeference a raster image (such as aerial pictures, etc.) and to put it into a map base.

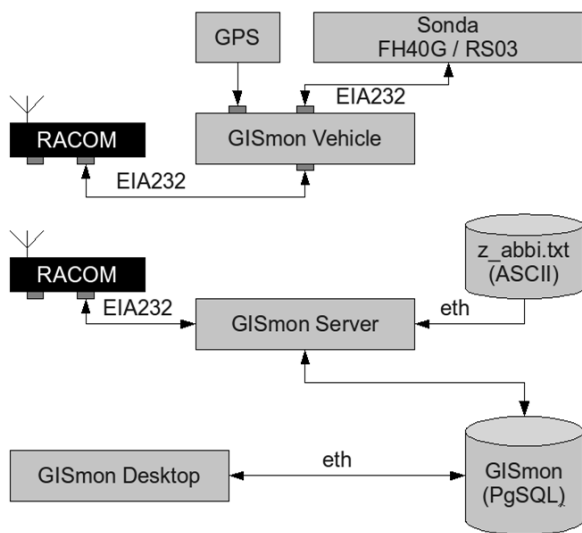

Fig. 2 Communication between mobile units and the dispatch centre

The system is modified and supplemented by special functions for viewing and processing dose rate data, measured by mobile units. It enables sending different, manually entered data, measured in other systems, as well. GISmon Desktop allows displaying these data and, if necessary, exporting them for further processing by external applications. GISmon Desktop performs the following functions:

- Displaying the current position and the measured values of selected/all mobile units
- Displaying the trajectory of selected/all mobile units
- Selecting and presenting position/trajectory and state of any mobile unit from historical data
- Defining trajectories of emergency plans
- Receiving and sending short text messages
- Displaying manually entered values from mobile units

The GISmon Vehicle system is used to measure dose rate in mobile units (vehicles) and to send the measured values to the

server. The application also enables requesting and viewing current data from the telemetry system of nuclear power plants. GISmon Vehicle allows measuring the dose rate of the following sondes:

- FH40g (connected via serial cable)
- RS03 with a serial connection, as well as with a USB connection

As the data source for the current position, GPS receiver with a serial interface and NMEA 0183 protocol can be used. The software processes the data from a report of the GPRMC type (Recommended minimum specific GPS/TRANSIT data).

GISmon Vehicle performs the following functions:

- Displaying the current position of a vehicle, with the dose rate being distinguished using colors
- Displaying a trajectory with viewing the dose rate on a map base
- Manual selecting a predefined trajectory (e.g. according to the wind direction)
- Measuring the dose rate of a sonde connected (RS03 / FH40G)
- Selecting and displaying the current data from selected sondes of a TDS system
- Receiving and sending short text messages to headquarters
- Local archiving measured and accepted data
- Manual entering selected values and sending them to the server
- Sending the data to the server via the RACOM radio modems
- GISmon Server performs the following functions:
 - Receiving the measured data from a vehicle and recording them into a local database
 - Receiving the manually entered data and recording them to a local database
 - Importing the TDS data from a CRCS through z_abbi.txt files and their short-term archiving to a local database
 - Sending required TDS data to a vehicle
 - Mediating the exchange of short text messages between the system participants
 - Providing the communication with vehicles through RACOM radio modems using MARS-A protocol.

III. SYSTEM IMPLEMENTATION

In the development of the information system, we used various software engineering methods and techniques. In particular, they included:

- Modelling techniques for modelling the individual research processes using BPMN 2.0 notation,
- Modelling techniques for modelling the analysis and design artefacts using UML 2.0 and CASE tool - Enterprise Architect,
- For implementing, RAD development environments and a database environment were used,
- For configuring management of design artefacts and implementation, the CVS system was used,
- For testing in individual tasks, a tool for managing test scenarios was used.

Communication between mobile units and the dispatching department is provided by a communication server. Client stations of the dispatching connect to this server via a local area network. RACOM radio modem is connected to the server, providing the connection to mobile units (Fig. 2).

In the current version of the system we implemented the possibility of two-way communication – an operator of the dispatching department is allowed to update the data and send the new route and further instructions to a mobile unit. This communication is provided by opening TCP ports on the server, thus creating a virtual tunnel directly into the computer of a mobile unit.

The basic window of the application is shown in Fig. 3. On the right, you can find the navigation menu. By default, at launch, a screen with the data monitor is displayed, where the current dose rate and the integral dose (from the application start or from a sonde statistics reset) is shown. In the lower part, indication of current speed and connection state of a sonde, modem and GPS are to be seen.

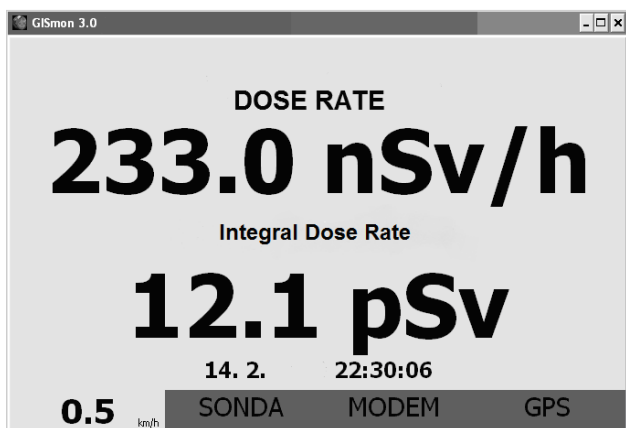

Fig. 3 Screen of the monitoring system in a mobile unit

Connection state of these interfaces is indicated by background color of a particular field. If a box is green, it means that everything is all right. The other colors mean:

- Yellow: for sonde - means that for a period of three cycles, the dose rate was not obtained, for modem - no response was obtained for period longer than 30 seconds, for GPS - GPS does not send data, or the GPS position is not obtained (bad signal).
- Blue - failed to open serial port of a device.
- Red - Problem with a device driver.

The application uses map bases created or imported in GISmon Desktop application. After launching, the application is loaded onto the selected map base and necessary imaging layers are created (Fig. 5). The color distinction of the measured dose rate level is provided by a legend. GISmon uses different layers for displaying data. Even the map base may consist of several layers with different content (municipalities, roads, buildings, etc.)

For displaying operating data and information, GISmon

uses the following layers:

- Route - allows plotting and displaying emergency trajectories of vehicles
- Sectors - displays defined sectors and zones
- reports - here the messages with GPS latitude/longitude coordinates are displayed
- TDS - displays solid TDS stations with information on the current dose rate
- Auto_x - displays the current data on the dose rate obtained from a vehicle ("x" stands for a number from 1 to 3)
- Auto_xh - displays the historical data from a vehicle, requested based on user's filtering. ("x" stands for a number from 1 to 3)

To a certain extent, each layer may be adapted by simple configuration of basic parameters.

Legend configuration is stored in the default. legend file. The legend configuration can be carried out using the GISmon Desktop application. After the configuration change, new file with the legend configuration should be uploaded into the working directory of the GISmon Vehicle application. The new legend configuration will be loaded automatically with a new launch of the application.

The application enables creating, saving and loading map bases, viewing and modifying their object database and defining, or adding/removing single layers of the map base.

In Fig. 4, map base with actually measured data is shown in detail. In the upper right corner, you can see a TDS station, varying in its color, as well as in the color of the displayed points, depending on the dose rate in the given area.

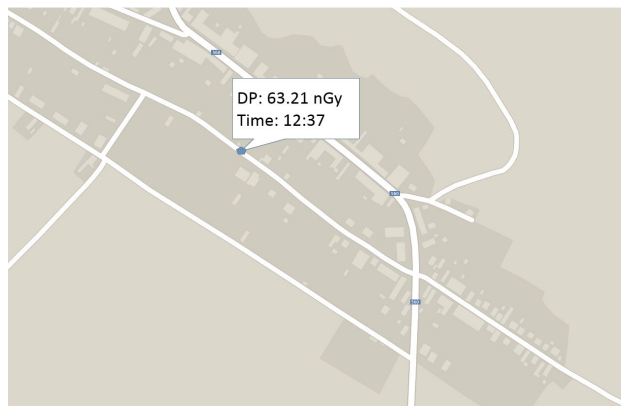

Fig. 4 Detail of the measured data

For each object, a record in the GIS application database is created, which enables later viewing the individual values.

Definition of the desired trajectory is another feature available in the application. For each variant of a crisis plan, several trajectories are provided, which can be loaded and viewed directly in the map base.

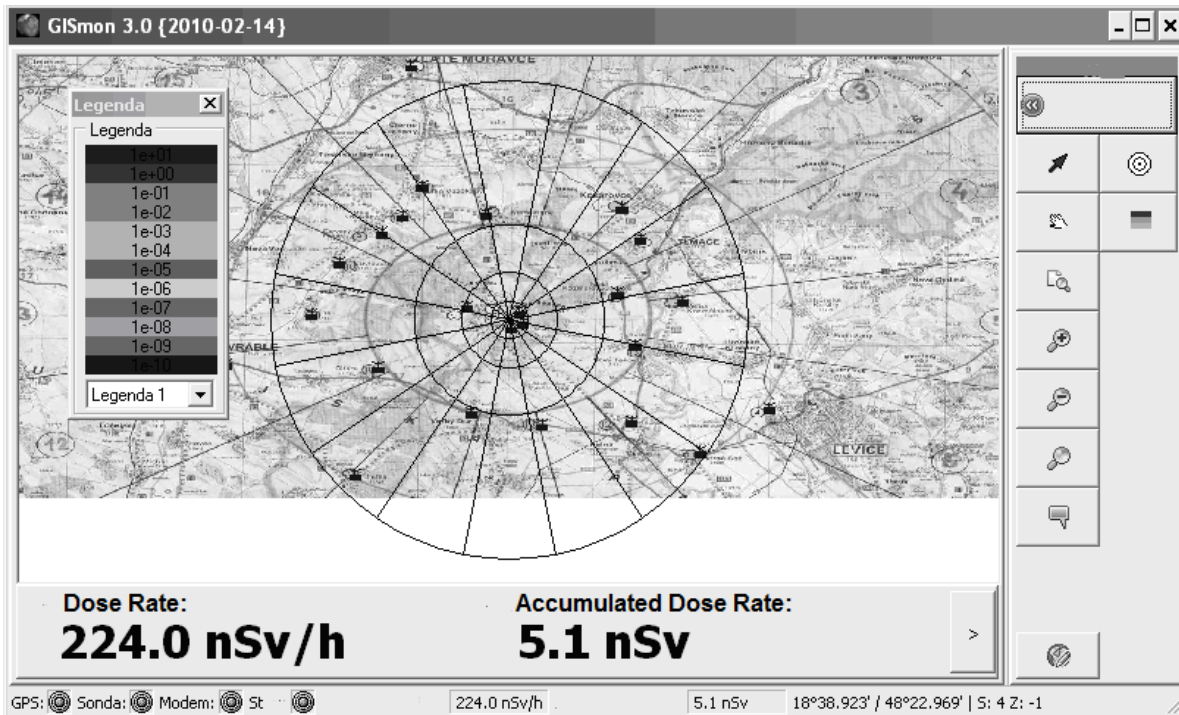

Fig. 5 Map base with a legend

The given route can be modified directly in the dispatch centre or control centre in real time, according to the needs of the situation. The results are directly displayed to a driver in the mobile device (Fig. 6).



Fig. 6 Detail of a possible positioning in a vehicle

IV. CONCLUSION

Implementing the proposed system, more accurate and faster evaluating the data on dose rate of LRKO was achieved, comparing by system [5]. The main benefits of the solution proposed include real-time data processing; graphical evaluation of measured data, including the option of changing the map base scale; reliable data transfer from the field to the main headquarters in LRKO and two-way communication between the dispatch centre and mobile units.

Other benefits also include:

- Real time displaying measured data, including the chart of measured data,
- Displaying data and position in the map base,
- Exporting and importing the selected layer to an external file for processing in other GIS systems,
- Defining routes for vehicles,
- Automatic backup of the measured data,
- Possibility of inserting any picture into a map base layer and ensuring displaying the image on a particular place (e.g. inserting air frames, or a drawing into a map).

REFERENCES

- [1] The Operational manual TDS for LRKO in the Nuclear Power plant SE-EBO. 2001
- [2] J. Kostial, and P. Buban, "Automatické spracovanie dávkových príkonov získaných z monitorovacích vozidiel pri monitorovaní okolia JE EBO," Laboratóriá radiačnej kontroly okolia EBO, SE a.s., AE Bohunice, 2005
- [3] O. Moravcik, P. Schreiber, and P. Tanuska, "The dose rate monitoring system," in *Scientific Buletin*, Vol. XXI / International Multidisciplinary Conference. 7th. Baia Mare, Romania, May 17-18, 2007, Baia Mare : North University of Baia Mare, pp. 481-486, May 2007, ISSN 1224-3264
- [4] O. Moravcik, P. Schreiber, and P. Tanuska, "LRKO Monitoring Information System," in *Proceedings of the 18th International Conference on Information and Intelligent Systems* : September, 12-14, 2007, Varaždin, Croatia: University of Zagreb, pp. 3-6, 2007, ISBN 978-953-6071-30-2
- [5] A. Elias, P. Tanuska, and P. Vazan, "Systém monitorovania dávkového príkonu prostredníctvom mobilných jednotiek" in *Materials Science and Technology*, Roč. 5, č. 5, 2005, ISSN 1335-9053
- [6] L. Drahosova, and J. Kostial, "Monitoring of Influence of exploitation of nuclear energetics facilities Bohunice on the environment," in *Workshop: Past and present trends of nuclear chemistry*, 2007