

# Exergetic and Sustainability Evaluation of a Building Heating System in Izmir, Turkey

Nurdan Yildirim, Arif Hepbasli

**Abstract**—Heating, cooling and lighting appliances in buildings account for more than one third of the world's primary energy demand. Therefore, main components of the building heating systems play an essential role in terms of energy consumption. In this context, efficient energy and exergy utilization in HVAC-R systems has been very essential, especially in developing energy policies towards increasing efficiencies. The main objective of the present study is to assess the performance of a family house with a volume of 326.7 m<sup>3</sup> and a net floor area of 121 m<sup>2</sup>, located in the city of Izmir, Turkey in terms of energetic, exergetic and sustainability aspects. The indoor and exterior air temperatures are taken as 20°C and 1°C, respectively. In the analysis and assessment, various metrics (indices or indicators) such as exergetic efficiency, exergy flexibility ratio and sustainability index are utilized. Two heating options (Case 1: condensing boiler and Case 2: air heat pump) are considered for comparison purposes. The total heat loss rate of the family house is determined to be 3770.72 W. The overall energy efficiencies of the studied cases are calculated to be 49.4% for Case 1 and 54.7% for Case 2. The overall exergy efficiencies, the flexibility factor and the sustainability index of Cases 1 and 2 are computed to be around 3.3%, 0.17 and 1.034, respectively.

**Keywords**—Buildings, exergy, low exergy, sustainability, efficiency, heating, renewable energy.

## I. INTRODUCTION

**I**N many countries, reducing fossil energy utilization and promoting renewable energies in the building sector have been very essential due to global warming considerations. Reductions in energy utilization can be achieved by minimizing the energy demand, rational energy utilization, recovering heat and cold and using energy from the ambient air and the ground. For keeping the environmental impact of a building at sustainable levels (e.g., by greenhouse gas neutral emissions), the residual energy demand must be covered with renewable energy [1].

Buildings consume energy throughout their whole life cycles, and many aspects and stages of building development and utilization impact their energy and environmental performances, from planning, design, construction and installation to test, commissioning, operation and maintenance [2].

The concept of exergy and exergy-economics has been attracted more and more attentions. Exergy analysis, which is a way to sustainability and reflects the extent of energy

utilization, veritably provides a new assessment method of energy efficiency [3]. Exergy may be defined in various ways [4] and indicates the maximum work potential of a system under certain conditions. All systems with different conditions from the environment contain exergy.

Exergy analysis method has been applied to various building heating systems using the low exergy (LowEx) approach in recent years to assess their performances from the primary energy production to the building envelope, as comprehensively reviewed by Hepbasli elsewhere [4].

The key issue is how to make buildings both energetically and exergetically sustainable. Exergy as a thermodynamic analysis tool may help achieve this objective. The LowEx approach is one of these approaches, which has been and still being successfully used in the design of sustainable buildings. In recent years, the number of various studies on LowEx heating/cooling systems, of which flow temperatures are very close to the room to be heated/cooled, has dramatically increased. Through the LowEx approach, the energy/exergy flows from the primary energy production to the building envelope are determined to indicate the potential for further improvements in the energy and exergy utilization at each stage of the building heating/cooling system.

Considering some LowEx studies, Balta et al. [5] investigated a ground source heat pump and a low exergy heating system. They presented energy and exergy flows for the selected building boundary conditions. Hasan et al. [6] assessed the performance of a building by using a dynamic simulation. Low temperature water heating system was compared with radiator and floor heating systems. Based on the results, the low temperature water heating system had more appropriate temperature levels. Yucer and Hepbasli [7] exergetically evaluated a building heating system serving for educational purposes. They investigated the system performance by stages, namely generation, distribution, emission, and building envelope while presenting energy and exergy flows of the building investigated.

The main objective of this contribution is to apply the Lowex approach to a family house from the generation stage to the building envelope to reveal the inefficiencies of the components and their interrelations.

## II. SYSTEM DESCRIPTION

In this study, a family house with a volume of 326.7 m<sup>3</sup> and a net floor area of 121 m<sup>2</sup> is considered as a case study [8]. The winter design outside temperature is 0°C for the city of Izmir while the design outside temperature can be taken as 1°C with 99.6% frequency [9]. That means the heating system

Nurdan Yildirim is with the Energy Systems Engineering Department, Yasar University, Bornova, 35100, Izmir, Turkey (e-mail: nurdan.yildirim@yasar.edu.tr).

Arif Hepbasli is with the Energy Systems Engineering Department, Yasar University, Bornova, 35100, Izmir, Turkey (e-mail: hepbasli@yasar.edu.tr).

will provide a thermal comfort at 99.6% of the time, but may fail to do so during 0.4% of the time. The indoor air temperature is taken as 20°C. The plan and panoramic view of the house is shown in Fig. 1. The architectural features, such as direction and size of walls and windows, are listed in Table I.

The construction materials are locally manufactured and

consist of brick for the walls, plaster for interior and exterior surfaces, reinforced concrete floors, ceilings, XPS and glass wool insulation. For this study, insulation, in accordance with the current Turkish building standard [10], in walls and ceiling as well as windows, the window shading was considered (Table II).



Fig. 1 Plan and panoramic view of the considered family house [8]

TABLE I  
THE ARCHITECTURAL FEATURES OF THE HOUSE

Space	Space Area (m <sup>2</sup> )	Direction	Walls			Windows			Doors		Net Wall Area (m <sup>2</sup> )	
			(m)	(m)	(m <sup>2</sup> )	(m)	(m)	(m <sup>2</sup> )	(m)	(m <sup>2</sup> )		
Saloon	30	G	5	2.7	13.5	1.5	1.3	1.95	2	2.2	4.4	7.15
			6	2.7	16.2	3	1.3	3.9				12.3
Parent Room	17.5	D	3.5	2.7	9.45							9.45
Parent Bathroom	6	K	5	2.7	13.5	1.5	1.3	1.95				11.55
Bedroom-1	17.5	D	1.5	2.7	4.05	0.6	0.6	0.36				3.69
Bedroom-1	17.5	K	5	2.7	13.5	1.5	1.3	1.95				11.55
			B	3.5	2.7	9.45	1.5	1.3	1.95			
Bedroom-2	12.25	B	3.5	2.7	9.45	1.5	1.3	1.95				7.5
			G	1.5	2.7	4.05						
Kitchen	14	B	4	2.7	10.8	1.5	1.3	1.95				8.85
			G	3.5	2.7	9.45				2	2.2	4.4
Bathroom	10	D	2	2.7	5.4	0.6	0.6	0.36				5.04
Hall	13.75	B	2	2.7	5.4				1	2.2	2.2	3.2
TOTAL	121				124.2			16.32			11	96.88

TABLE II  
THE THICKNESS AND CALCULATED U (THERMAL TRANSMITTANCE) VALUES OF THE BUILDING CONSTRUCTION MATERIALS

Layers	Thermal Conductivity (W/mK)	Exterior Wall (m)	Ceiling (m)	Floor (m)
Inner Plaster	1.4	0.015	0.015	0.02
Brick	0.68	0.19	-	-
Reinforced cement	-	-	0.15	0.20
Exterior Plaster	1.4	0.015	0.015	0.02
Sand-Gravel	2.0	-	-	0.10
XPS insulation	0.04	0.05	-	-
Glass wool	0.04	-	0.08	0.05
U-(Thermal transmittance)	(W/m <sup>2</sup> K)	0.581	0.447	0.615

Fig. 2 shows the energy flows in forms of primary and electricity for a building from the primary energy transformation through the heat generation system and the

distribution system to the heating system, and from there, via the indoor air, across the building envelope to the surrounding air.

For the heating applications, two options are studied with 1- a condensing boiler and 2- an air heat pump. The radiators are considered as heating systems. The distribution systems are considered to have good insulation. The domestic hot water (DHW) energy demand is ignored in this study.

III. ANALYSIS

The energy and exergy analyses of the considered systems are made through an Excel tool, which has been developed within the framework of International Energy Agency (IEA) formed within the Energy Conservation in Buildings and Community Systems Programme (ECBCSP) Annex 37 [11]. The tool and the calculation approach follow the method developed by Schmidt [12]. The main equations of the energy and exergy analyses are listed in Tables III and IV.

TABLE III  
MAIN EQUATIONS OF ENERGY ANALYSIS

Heat Losses	
Transmission heat loss rate [W]	$\dot{Q}_T = \sum(U_i \cdot A_i \cdot F_{xi})(T_i - T_o)$ (1)
Ventilation heat loss rate [W]	$\dot{Q}_V = (c_p \cdot \rho \cdot V \cdot n_d \cdot (1 - \eta_V))(T_i - T_o)$ (2)
Heat Gains	
Solar heat gain rate [W]	$\dot{Q}_S = \sum(I_{s,j} \cdot (1 - F_f) \cdot A_{w,j} \cdot g_j \cdot F_{sh} \cdot F_{no})$ (3)
Internal gain rate of occupants [W]	$\dot{Q}_o = \dot{Q}_o^{no_o}$ (4)
Internal gain rate of equipment [W]	$\dot{Q}_e = \dot{Q}_e \cdot A_N$ (5)
Other Uses	
Lighting power [W]	$P_l = p_l \cdot A_N = \dot{Q}_l$ (6)
Ventilation power [W]	$P_V = p_V \cdot V \cdot n_d$ (7)
Heat Demand	
Heat demand rate [W]	$\dot{Q}_h = (\dot{Q}_T + \dot{Q}_V) \cdot (\dot{Q}_S + \dot{Q}_o + \dot{Q}_e + \dot{Q}_l)$ (8)
Specific heat demand rate [W/m <sup>2</sup> ]	$\dot{Q}_h^s = \dot{Q}_h / A_N$ (9)

TABLE IV  
MAIN EQUATIONS OF EXERGY ANALYSIS

Exergy Calculation		
Envelope	Quality factor room air [-]	$F_{q,air} = 1 - T_o / T_i$ (10)
	Exergy load rate of the room [W]	$\dot{E}x_{air} = F_{q,air} \cdot \dot{Q}_h$ (11)
Indoor air	Heating temperature [°C]	$T_{heat} = 0.5(T_{in} - T_{ret}) / \ln((T_{in} - T_i) / (T_{ret} - T_i)) + T_i$ (12)
	Quality factor air at heater [-]	$F_{q,heat} = 1 - T_{ref} [K] / T_{heat} [K]$ (13)
	Exergy load rate at the heater [W]	$\dot{E}x_{heat} = F_{q,heat} \cdot \dot{Q}_h$ (14)
Heating system	Heat loss rate [W]	$\dot{Q}_{loss,HS} = \dot{Q}_h \cdot (1 / \eta_{HS} - 1)$ (15)
	Auxiliary energy rate [W]	$P_{aux,HS} = p_{aux,HS} \cdot \dot{Q}_h$ (16)
	Exergy demand rate [W]	$\Delta \dot{E}x_{HS} = (\dot{Q}_h + \dot{Q}_{loss,HS}) / (T_{in} - T_{ref}) \cdot \left\{ (T_{in} - T_{ret}) - T_{ref} \cdot \ln(T_{in} / T_{ret}) \right\}$ (17)
Distribution	Heat loss rate [W]	$\dot{Q}_{loss,dis} = (\dot{Q}_h + \dot{Q}_{loss,HS}) \cdot (1 / \eta_{dis} - 1)$ (18)
	Auxiliary energy rate [W]	$P_{aux,dis} = p_{aux,dis} \cdot (\dot{Q}_h + \dot{Q}_{loss,HS})$ (19)
	Exergy demand rate [W]	$\Delta \dot{E}x_{dis} = \dot{Q}_{loss,dis} / \Delta T_{dis} \cdot \left\{ T_{dis} - T_{ref} \cdot \ln(T_{dis} / (T_{dis} - \Delta T_{dis})) \right\}$ (20)
Generation	Required energy rate [W]	$\dot{Q}_{HP} = (\dot{Q}_h + \dot{Q}_{loss,HS} + \dot{Q}_{loss,dis}) \cdot (1 - F_S) / \eta_{HP}$ (21)
	Auxiliary energy rate [W]	$P_{aux,HP} = p_{aux,HP} \cdot (\dot{Q}_h + \dot{Q}_{loss,HS} + \dot{Q}_{loss,dis})$ (22)
	Exergy load rate [W]	$\dot{E}x_{HP} = \dot{Q}_{HP} \cdot F_{q,S}$ (23)
Energy transformation	DHW energy demand rate [W]	$P_W = V_W \cdot \rho \cdot C_p \cdot \Delta T_{DHW} \cdot no_o / \eta_{DHW}$ (24)
	Exergy load rate of the plant [W]	$\dot{E}x_{plant} = (P_l + P_V) \cdot F_{q,el}$ (25)
	Required primary energy input rate [W]	$\dot{E}p_{tot} = \dot{Q}_{HP} \cdot F_p + (P_l + P_V + P_{aux,HP} + P_{aux,dis} + P_{aux,HS}) \cdot F_{p,el} + P_W \cdot F_{DHW}$ (26)
Energy transformation	Additional renewable energy input rate [W]	$\dot{E}R = \dot{Q}_{HP} \cdot F_R + \dot{E}_{env}$ (27)
	Total exergy input rate [W]	$\dot{E}x_{tot} = \dot{Q}_{HP} \cdot F_p \cdot F_{q,s} + (P_l + P_V + P_{aux,HP} + P_{aux,dis} + P_{aux,HS}) \cdot F_{p,el} + \dot{E}R \cdot F_{q,R} + P_W \cdot F_{DHW} \cdot F_{q,S,DHW}$ (28)

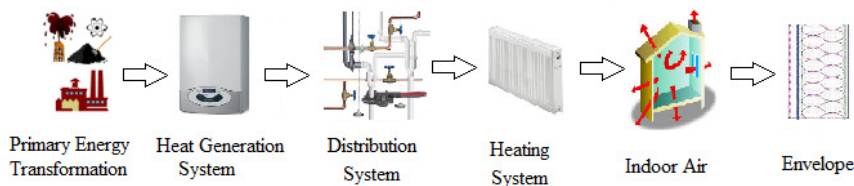

Fig. 2 Energy flow from primary energy transformation to the environment

In Case 1, a condensing boiler is used for the heat generation with a maximum supply temperature of 70°C and its efficiency is taken as 0.95. For Case 2, an air heat pump is used with COP of 2.50 and a maximum supply temperature of 80 °C. The supply and return temperatures of the radiators are taken as 70°C and 60°C with a heat loss/efficiency of 0.95, respectively. Main assumptions and constant parameters of the analysis are given in Table V [13].

For the energy source in the primary energy transformation, the given parameters,  $F_p$  and  $F_{q,s}$  are the figures of the primary energy factor and the quality factor of the energy source, respectively. FR is a fraction factor.

The total energy input rate per area in unit of  $W/m^2$  is calculated by

$$\dot{E}''_{tot,pa} = \dot{E}_{tot} / A_N \quad (29)$$

The total energy input rate per volume in unit of  $W/m^3$  is calculated by

$$\dot{E}''_{tot,pv} = \dot{E}_{tot} / V_N \quad (30)$$

The total exergy input rate per area in unit of  $W/m^2$  is calculated by

$$\dot{E}x''_{tot,pa} = \dot{E}x_{tot} / A_N \quad (31)$$

TABLE V  
MAIN ASSUMPTIONS OF THE ENERGY AND EXERGY ANALYSIS

	Parameter	Unit	Symbol	Value	
Heat Losses	Air exchange rate	[ach/h]	$n_d$	0.4	
	Heat exchanger efficiency	[-]	$\eta_V$	0.8	
	Specific heat of indoor air	[kJ/kgK]	Cp	1.005	
	Density of indoor air	[kg/m <sup>3</sup> ]	$\rho$	1.2	
Heat Gains	Window frame fraction	[-]	$F_f$	0.3	
	Total transmittance	[-]	$g_j$	0.58	
	Solar radiation: SE to SW, NW to NE	[W/m <sup>2</sup> ]	$I_{s,j}$	20	
	Other directions			50	
	Emitted heat per occupant	[W/person]	$\dot{Q}'_o$	80	
	Specific internal gains of equipment	[W/m <sup>2</sup> ]	$\dot{Q}'_e$	2.05	
Other Uses	Specific lighting power	[W/m <sup>2</sup> ]	$P_l$	2	
	Specific ventilation power	[W/m <sup>2</sup> ]	$P_V$	0.26	
Distribution System	Temperature drop	[K]		<5	
	Heat loss/efficiency	[-]	$\eta_{dis}$	0.86	
	Auxiliary energy	[W/kW <sub>heat</sub> ]	$P_{aux,dis}$	9.02	
Storage	Solar fraction	[-]	$F_S$	0	
Heating System	Radiator inlet temperature	[°C]	$T_{in}$	70	
	Radiator return temperature	[°C]	$T_{ret}$	60	
	Auxiliary energy	[W/kW <sub>heat</sub> ]	$P_{aux,HS}$	0.2	
	Max. heat emission	[W/m <sup>2</sup> ]	$P_{heat,max}$	100	
	Heat loss/efficiency	[-]	$\eta_{HS}$	0.95	
Generation	Efficiency	[-]	$\eta_{CB}$	Case 1 0.95	Case 2 2.5
	Primary energy factor source	[-]	$F_p$	1.30	3
	Quality factor of source	[-]	$F_{q,s}$	0.95	1
	Max. supply temperature	[°C]	$T_{CB,max}$	70	80
	Auxiliary energy	[W/kW <sub>heat</sub> ]	$P_{aux,Gen}$	1.80	10
	Auxiliary energy constant	[W]	$P_{aux,gen,const}$	20	
	Primary energy electricity factor	[-]	$F_{p,el}$	3	3

The total exergy input rate per volume in unit of  $W/m^3$  is calculated by

$$\dot{E}x''_{tot,pv} = \dot{E}x_{tot} / V_N \quad (32)$$

The total energy efficiency of the system (%) is expressed as follows:

$$\eta_{sys} = \dot{E}_{building} / \dot{E}_{tot} \quad (33)$$

The total exergy efficiency of the system (%) is expressed as follows:

$$\psi_{sys} = \dot{E}x_{building} / \dot{E}x_{tot} \quad (34)$$

The exergy destruction rate of the system (W), can be calculated from:

$$\dot{E}x_{dest} = (1 - \psi_{sys}) \dot{E}x_{tot} \quad (35)$$

The exergy flexibility factor is calculated by

$$F_{flex} = \dot{E}x_{HS} / \dot{E}x_{tot} \quad (36)$$

The relation between the exergy efficiency ( $\psi$ ) and the sustainability index (SI) can be given as follows:

$$\psi = 1 - 1/SI \quad (37)$$

This relation shows how sustainability is affected by changing the exergy efficiency of a process [13].

#### IV. RESULTS AND DISCUSSION

In this study, the performance of a family house with a volume of 326.7 m<sup>3</sup> and a net floor area of 121 m<sup>2</sup>, located in the city of Izmir, Turkey is evaluated in terms of energetic, exergetic and sustainability aspects. The indoor and exterior air temperatures are taken as 20°C and 1°C, respectively.

Using the data in Table V, and (1) and (2), the total heat loss rate is calculated to be 3770.72 W. The heat gain rates from solar, internal and other power demand (e.g. sum of lighting power and ventilation power) are obtained to be 335.44 W, 248.68 W and 275.98 W using (3)-(7), respectively. According to these data, the heat demand rate and the specific heat demand rate of the building calculated from (8) and (9) are 2744.66 W and 22.68 W/m<sup>2</sup>, respectively.

An energy flow in the subsystems is calculated and given in Table VI and illustrated in Fig. 3.

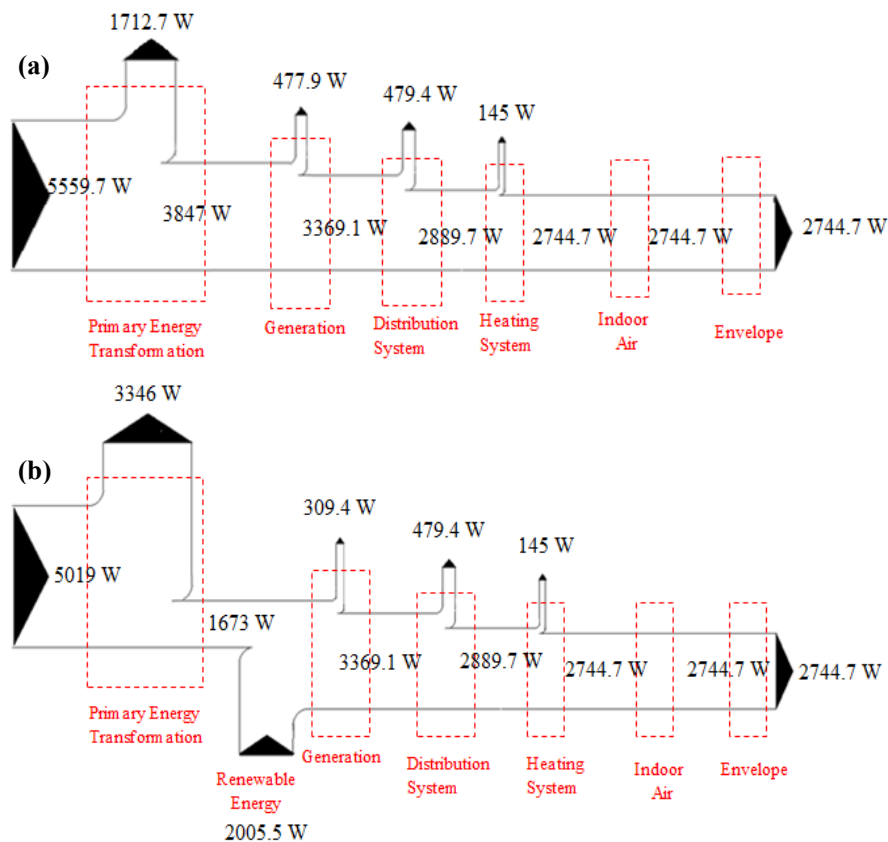

Fig. 3 Energy flow diagrams for (a) condensing boiler, (b) air heat pump

The system requires a primary energy rate of 5559.7 W for Case 1 and 5019 W for Case 2, respectively in order to supply a total of 2744.66 W to the building. As can be seen in Table VI, the energy demand of the indoor air, the heating system and the distribution system are equal for all cases.

TABLE VI  
ENERGY AND EXERGY FLOWS IN THE SUBSYSTEMS OF THE STUDIED CASES

Subsystems\ Studied Cases		Energy Flow (W)		Exergy Flow (W)	
		Case 1	Case 2	Case 1	Case 2
Input	1	5559.7	5019.0	5331.0	5019.0
After primary transformation	2	3847.0	1673.0	3618.5	1613.0
After generation	3	3369.1	3369.1	1032.3	1032.3
After distributon	4	2889.7	2889.7	907.3	907.3
After heating system	5	2744.7	2744.7	360.2	360.2
After indoor air	6	2744.7	2744.7	177.9	177.9
After envelope	7	2744.7	2744.7	0	0

The highest amounts of the heat loss rates occur in the primary energy transformation. In Case 2, after the primary energy transformation, an increase occurs. The explanation for this increase is that the amount of the renewable

environmental heat rate is included in this system as 2005.5 W.

The total exergy demand rate is determined based on the methodology as followed in the energy demand calculation, but with exergy analysis. The exergy demand rates are calculated as 5331 W and 5019.0 W, respectively for Cases 1 and 2 (Table VI).

The exergy flow diagram of the system is shown in Fig. 4. As can be seen in Fig. 4, the amount of exergy is consumed in each component for all cases. While the flow of energy leaves the building envelope, as seen in Fig. 3, there is still a remarkable amount of energy left, but this is not true for exergy (Fig. 5). Therefore, the exergy flow at the last row of Table VI is required to be zero.

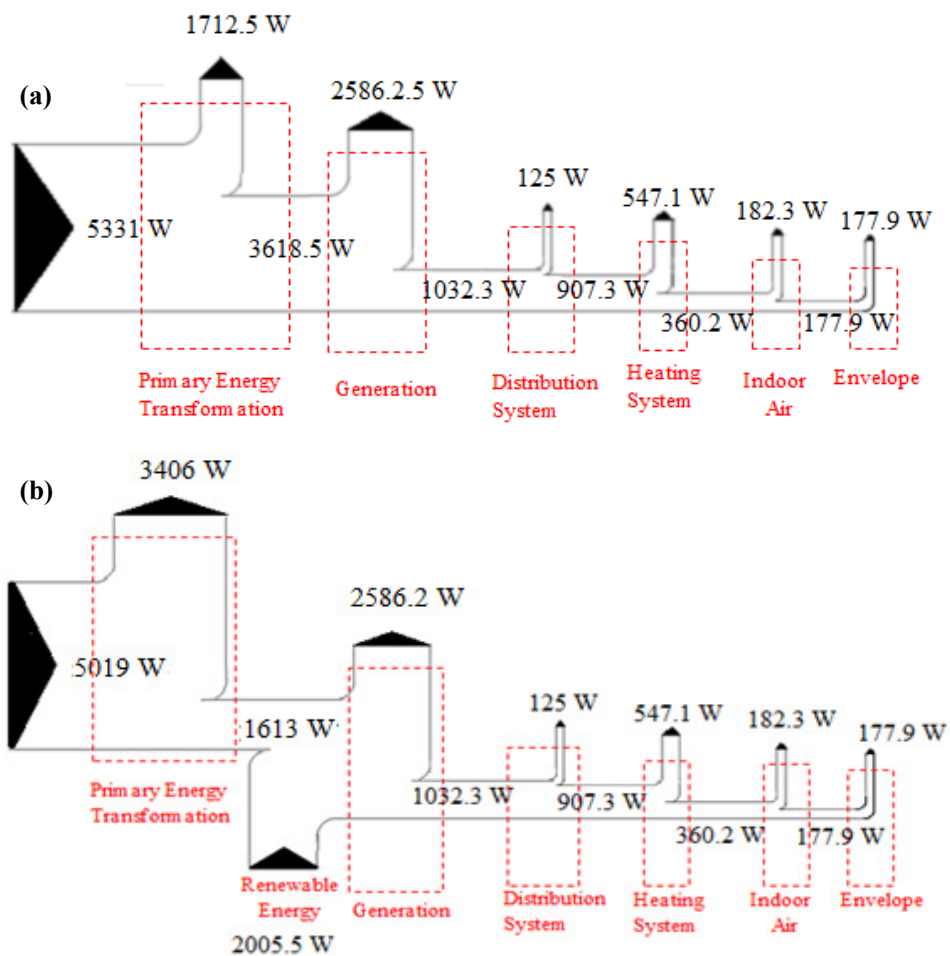

Fig. 4 Exergy flow diagrams for (a) condensing boiler, (b) air heat pump

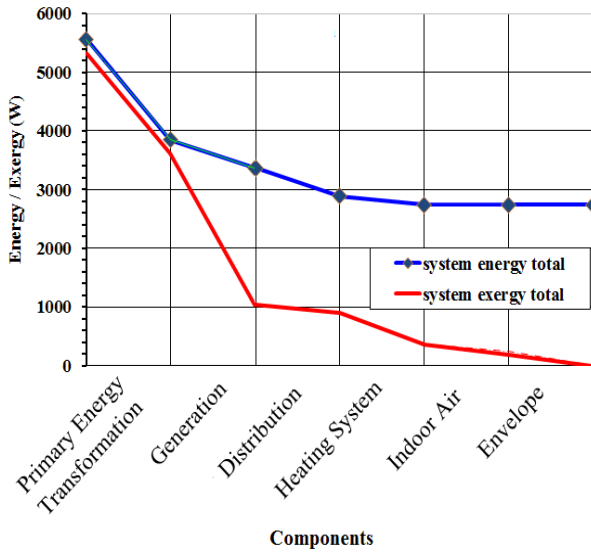

Fig. 5 Energy and exergy flow rates through components of Case 1

The variations of the energy and exergy loss rates through the components are illustrated in Fig. 6 and given in Table VII. The highest exergy loss rate (3406.0 W) occurs in the heat generation components of Case 2.

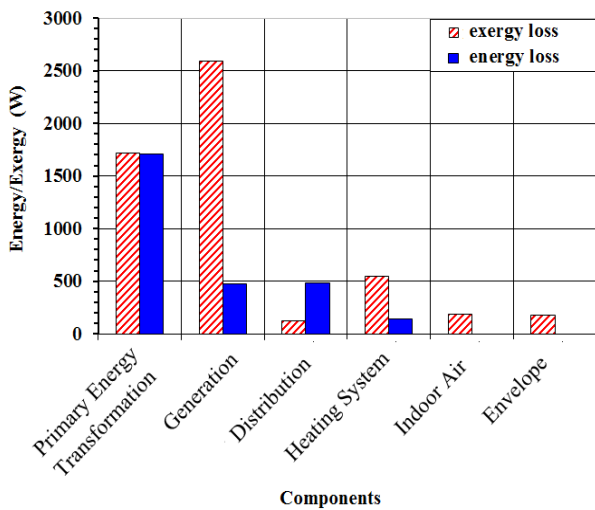

Fig. 6 Variation of energy and exergy loss rates through components

TABLE VII  
ENERGY AND EXERGY LOSS RATES OF THE SUBSYSTEMS

Subsystems\ Studied Cases	Energy Loss Rate (W)		Exergy Loss Rate (W)	
	Case 1	Case 2	Case 1	Case 2
After primary transformation	1712.7	3346.0	1712.5	3406.0
After generation	477.9	309.4	2586.2	2586.2
After distributon	479.4	479.4	125.0	125.0
After heating system	145.0	145.0	547.2	547.2
After room	0.0	0.0	182.3	182.3
After envelope	0.0	0.0	177.9	177.9

Results of the energy and exergy analyses are summarized in Table VIII. The overall energy efficiencies of the studied cases are determined to be 49.4% and 54.7%. The overall exergy efficiencies, the flexibility factor and the sustainability index of Cases 1 and 2 are calculated to be 3.3%, 0.17 and 1.034, respectively.

V. CONCLUSIONS

In this study, comprehensive energy and exergy analyses for sustainable buildings are considered and applied to two different heating options (1) a condensing boiler, and (2) an air heat pump for a building in Izmir with a net area of 121 m<sup>2</sup>. Their performances are compared through energy and exergy efficiencies. The energy and exergy results, the energy dispersals, the exergy flows and the exergy destructions are quantified and illustrated for comparison purposes.

The main conclusions drawn from the results of the present study may be listed as follows:

- The energy demand rate of the building is 2744.7 W.
- The system requires primary energy rates of 5559.7 W and 5019 W for Cases 1 and 2, respectively.
- The exergy demand rates of the heating systems are determined as 5331 W for Case 1 and 5347.1 W for Case 2.
- The highest exergy loss rate of 3406.0 W occurs in the heat generation components of Case 2.
- The overall energy efficiencies of the studied cases are calculated to be 49.4% and 54.7%.

The overall exergy efficiencies, the flexibility factor and the sustainability index of Cases 1 and 2 are calculated to be 3.3%, 3.5%, 0.17, 0.18 and 1.034, respectively.

TABLE VIII  
RESULTS OF THE ENERGY AND EXERGY ANALYSES AND TOTAL ENERGY AND EXERGY INPUT PER AREA/VOLUME

Studied cases	$\eta_{sys}$ (%)	$\psi_{sys}$ (%)	$\dot{E}x_{dest}$ (W)	$\dot{E}n_{tot,pa}$ (W/m <sup>2</sup> )	$\dot{E}n_{tot,pv}$ (W/m <sup>3</sup> )	$\dot{E}x_{tot,pa}$ (W/m <sup>2</sup> )	$\dot{E}x_{tot,pv}$ (W/m <sup>3</sup> )	$F_{flex}$ (-)	SI (-)
Case 1	0.494	0.0334	5153.12	45.95	17.02	44.06	16.32	0.1702	1.0345
Case 2	0.547	0.0354	4841.11	41.48	15.36	41.48	15.36	0.1808	1.0344

NOMENCLATURE

- A area (m<sup>2</sup>)
- cp specific heat at constant pressure (kJ/kg.K)
- $\dot{E}$  energy rate (W)
- $\dot{E}x$  exergy rate (W)

- f approximation factor (-)
- F factor (-)
- g total transmittance (-)
- I radiation intensity (W/m<sup>2</sup>)
- l length (m)
- N percentage of equipment resistance

nd	air exchange rate (1/h)
no	number (-)
P	power (W)
p	specific power, pressure ( $W/m^2$ , $N/m^2$ )
$\dot{Q}$	heat transfer rate (kW)
R	pressure drop of the pipe (Pa/m)
SI	sustainability index (-)
T	temperature (K)
U	thermal transmittance ( $W/m^2K$ )
$\dot{v}$	volumetric flow rate ( $m^3/s$ )
V	volume ( $m^3$ )

*Greek letters*

$\eta$	energy efficiency (-)
$\psi$	exergy efficiency (-)
$\rho$	density ( $kg/m^3$ )
$\Delta$	difference

*Subscripts*

air	indoor air
aux	auxiliary energy requirement
circ	circulation
dest	destruction
dis	distribution system
dt	design temperature
En	energetic
Ex	exergetic
e	equipment
el	electricity
env	environment
ex	external
f	window frame, parameter
flex	flexibility
HP	heat production system
HPP	heat production system position
HS	heating system
h	heat
heat	heater
i	indoor, counting variable
in	input, inlet
ins	insulation
j	counting variable
l	lighting
loss	thermal losses
max	maximum
N	netto
no	effect of non-orthogonal radiation
o	outdoor, occupants
p	primary energy
pa	per area
plant	plant
pv	per volume
q	quality
R	renewable energy
ref	reference
ret	return
S	solar,
s	source
sh	shading effects
sys	system
T	transmission
td	temperature drop

tot	total
usf	useful
V	ventilation
w	window,water
x	part x

*Superscripts*

over	dot	rate
------	-----	------

*Abbreviations*

COP	coefficient of performance
DHW	domestic hot water
ECBCS	energy conservation in buildings and community systems programme
IEA	international energy agency
LowEx	low exergy

## REFERENCES

- [1] A. M. Omer, "Renewable building energy systems and passive human comfort solutions" *Renewable and Sustainable Energy Reviews*, 2008, 12, pp.1562-87.
- [2] B. Kilkis, "Exergy aspects of operative temperature and its implications on sustainable building performance. Raising Efficiency to New Levels, New Mexico", *ASHRAE Transactions*, July, 2010.
- [3] Ping Wang, Guangcai Gong, Ying Wang, Long Li, "Thermodynamic investigation of building integrated energy efficiency for building retrofit", *Energy and Buildings*, 2014, 77, pp.139-148.
- [4] A. Hepbasli. "Low exergy (LowEx) heating and cooling systems for sustainable buildings and societies", *Renewable and Sustainable Energy Reviews*, 2012, 16,1, pp. 73-104.
- [5] M.T. Balta, Y. Kalinci, A. Hepbasli. "Evaluating a low exergy heating system from the power plant through the heat pump to the building envelope", *Energy and Buildings*, 2008, 40, pp. 1799-1804
- [6] A. Hasan, J. Kurnitski, K. Jokiranta, "A combined low temperature water heating system consisting of radiators and floor heating", *Energy and Buildings*, 2009, 41, pp. 470-479.
- [7] C.T. Yucer, A. Hepbasli, "Thermodynamic analysis of a building using exergy analysis method", *Energy and Buildings*, 2011, 43, pp. 536-542.
- [8] Single family house project, <http://www.muskon.com/253.htm>
- [9] T. Yilmaz, H. Bulut, "New Design Outside Temperature Values of Turkey", *Proceedings of V. National Sanitary Systems Engineering Congress and Exhibition, Izmir, Turkey*, 2001, (in Turkish).
- [10] TS 825, Turkish Standard, Heat Insulation Rules in Buildings, 1998.
- [11] IEA, Low exergy heating and cooling of buildings--Annex 37.<http://www.vtt.fi/rte/projects/annex37/Index.htm>, 2008 (retrieved 19.05.08).
- [12] D. Schmidt, "Design of low exergy buildings-method and a pre-design tool", *International Journal of Low Energy and Sustainable Buildings*, 2003, 1-47.
- [13] M.T. Balta, I. Dincer, A. Hepbasli, "Performance and sustainability assessment of energy options for building HVAC applications", *Energy and Buildings*, 2010, 42, pp. 1320-1328.
- [14] M.T. Balta, I. Dincer, A. Hepbasli, "Development of sustainable energy options for buildings in a sustainable society", *Sustainable Cities and Society*, 2011, 1, pp.72-80.
- [15] M. T. Balta, "Exergetic cost analysis and sustainability assessment of various low exergy heating systems", *Energy and Buildings*, 2012, 55 721-727.

**Nurdan Yildirim** is an Assistant Professor in the Department of Energy Systems Engineering at Yasar University She has obtained her B.S. degree in Mechanical Engineering from Dokuz Eylul University in 1999, and her M.Sc and Ph. D degrees in Mechanical Engineering from Izmir Institute of Technology in 2003 and 2010, respectively. In 2002, she attended a six-month "United Nations Geothermal Training Programme" at Reykjavik, Iceland, on an Iceland government and United Nations University fellowship. In 2005, she attended a nine-month "Diploma Course on Environmental and Applied Fluid Dynamics Department" at Von Karman Institute for Fluid Dynamics, Belgium, received a NATO fellowship. She worked as a research assistant in



Mechanical Engineering Department at İzmir Institute of Technology between 2000-2010. Then she served as a Project manager at Energy Department of Megapol Group in Izmir until March 2013. She was also an adjunct faculty in Gediz University in 2011, and taught Thermodynamics. She is a certified Energy Manager and additionally she has Professional Engineer Certificate on Air-Conditioning, Ventilating, Refrigerating, Heating, Sanitary and Heat Insulation. Her main research interests are renewable energy systems mainly geothermal energy (modeling and simulation of geothermal district heating system and geothermal power plants), energy management and energy efficiency.

**Arif Hepbasli** is currently a Professor and Head of Energy Systems Engineering Department at Yasar University. He worked for 10 years in various Turkish energy companies before joining Ege University (Turkey) in 1996. He was Vice Director of the Solar Energy Institute of Ege University (1997-2000) and Ege University Science Technology Application and Research Center (2000-01). His research has been related with energy, exergy, exergo-economic and exergo-environmental analyses and assessment of energy-related systems, and management, utilization and potential of renewable energy sources, sustainable energy technologies, and energy efficient buildings. He is a Certified Industrial Energy Manager, and has authored and co-authored more than 530 conference and journal papers, also on the topics in the proposal (over 260 SCI papers with  $h=34$ ). He has chaired/co-chaired many national and international conferences, symposia, workshops and technical meetings. He was a consultant in cases involving his research area and is a member of the editorial board of 8 prestigious international journals (Energy Sources, Energy and Buildings, Int J Energy, Int J Exergy, Int J Green Energy, J Sustainable Energy Eng, Int J Sustainable Avitation, and Int J Advanced Thermofluid Research). Dr. Hepbasli's current projects are funded by the FP-7 projects REELCOOP and ECOSHOPPING, and he also is a principal investigator in a novel heat pump design project funded by TUBITAK.