

# Decision Support System for Tourism in Northern Part of Thailand

Katejarinporn Chaiya, Thawit Janbanklong

**Abstract**—The purposes of this study were to design and find users' satisfaction after using the decision support system for tourism northern part of Thailand, which can provide tourists touristic information and plan their personal voyage. Such information can be retrieved systematically based on personal budget and provinces. The samples of this study were five experts and users 30 persons white collars in Bangkok. This decision support system was designed via ASP.NET. Its database was developed by using MySQL, for administrators are able to effectively manage the database. The application outcome revealed that the innovation works properly as sought in objectives. Specialists and white collars in Bangkok have evaluated the decision support system; the result was satisfactorily positive.

**Keywords**—Decision Support System, ASP.NET, MySQL.

## I. INTRODUCTION

AT the moment, touristic industry positively weighs in Thai economy because it is considered a factor generating benefits to various parts of the country. The industry growth rate, hence, progresses significantly. Such rise affects tourists' decision making. In Thailand there are various interesting destinations, especially in the Northern part which attracts tourists by its touristic sites, weather, culture, and local lifestyle [1], [11].

Generally, online resources on touristic places only provide basic information sites, restaurants, and accommodations. Interested tourists will have to decide whether, to easily commute, there are approximate touristic places, and how much budget the tourists have to invest on a visit. Finding this information takes a lot of time [2].

The innovative website is more effective than the current online resources, which only provide general aspects on touristic sites. The technology helps tourists determine the destination; the users merely provide their needs based on factors. The system, then, groups approximate places for the journey facilitation. It also supports determining touristic cost on each trip due to limited budget of tourists; so as to maximize the benefit based on the money invested [3].

Katejarinporn Chaiya is with the Information Management Faculty of Humanities and Social Sciences, Suansunandha Rajabhat University, Bangkok Thailand (phone: +6690-929-3948 e-mail: katejarinporn.ch@ssru.ac.th).

Thawit Janbanklong is with the Italthai Group, Italthai Industrial, Bangkok Thailand (phone: +6683-777-9357; e-mail: twiz@windowslive.com).

## II. PURPOSE

The purpose of this study was to design a decision support system for tourism northern part of Thailand and find user satisfaction after using the system.

## III. LITERATURE REVIEW

Decision support system means sub-system of information management, and the system to help management team to decide in decision of event or business that has uncertain structure, or half of certain, the system may be used with one person or decision of group, also support manager to decide the strategy [4].

Tourism is a collection of activities, services and industries that delivers a travel experience, including transportation, accommodations, eating and drinking establishments, retail shops, entertainment businesses, activity facilities and other hospitality services provided for individuals or groups traveling away from home [5], [6].

History of the North Thailand is also a place steeped in history and culture. Home to Yonok and Lanna Kingdoms, the north is awash with temples, museums, historical sites and arte facts that testify to the region's historical significance. But the north is equally placed in the modern world – Chiang Mai (the region's focal point for tourism) is a modern city with clubs and pubs and entertainment befitting any major city [7].

ASP.NET is a unified web development model integrated with .NET framework, designed to provide services to create dynamic web applications and web services. It is built on the Common Language Runtime of the .NET framework and includes those benefits like multi-language interoperability, type safety, garbage collection and inheritance [8].

MySQL is abbreviated from structured query language means language used in writing program to keep in database specifically, and is related databases standard language and is open system which means we can command SQL with any database and one command when we command by different database. The result is we can select any database without depending on one database, beside SQL is also database program which SQL was structural database that is easy to understand, effectively only little command, program SQL is proper for using with related database system [9].

## IV. METHODOLOGY

### A. Sample

The sample used in this study consisted of five experts who have experience in tourism and users 30 persons.

**B. Research Tools**

- 1) Decision support system for tourism northern part of Thailand
- 2) Decision support system manual
- 3) Evaluation form

**C. Research Procedures**

- 1) The decision support system for tourism northern part of Thailand has been developed to delimit the previous system. This innovation is divided into 2 main parts: users and administrators sections. The diagram presents the input data and output information:

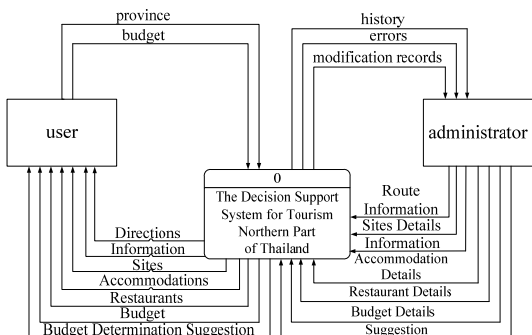

Fig. 1 Context Diagram

- 2) Data Flow Diagram: DFD is the tool to show step of total operation of database to support decision of tourism northern part of Thailand, it consisted of main principles as follows:

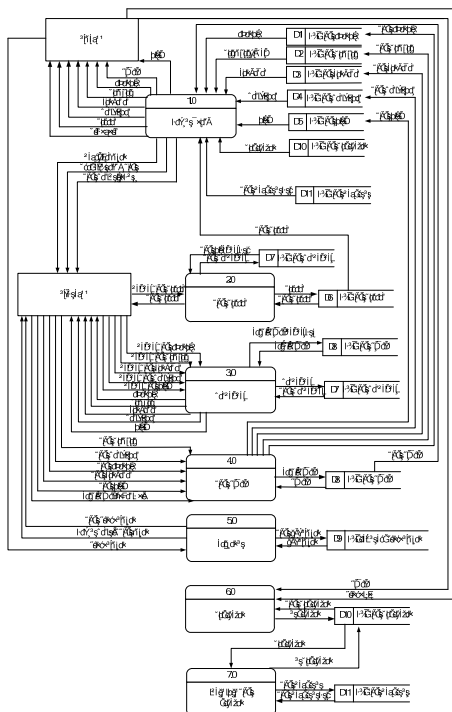

Fig. 2 Level 0 Diagram

**D. Data Collection**

- 1) Construct the decision support system for tourism in northern part of Thailand
- 2) Produce evaluation form
- 3) The evaluation form was sent to five experts and 30 users for evaluating the system

**E. Data Analysis**

The data obtained from the experts and the users were analyzed by using the statistics as follows

- 1) Functional requirement test was to rate the accuracy and the effectiveness of the system based on the users' needs;
- 2) Usability test was to rate the interactivity of the program
- 3) Performance test was to rate the effectiveness based on the needs
- 4) Security test was to rate the security of the data

The evaluation proposed both qualitative and quantitative ratings which were classified as stated in the following chart [10]:

TABLE I  
THE EVALUATION OF THE ASSESSMENT SYSTEM

Rating	Meaning
5	Very Good
4	Good
3	Moderate
2	Quite Ineffective
1	Ineffective

The evaluation analysis deployed two statistic values: Arithmetic Mean and Standard Deviation.

**V. RESULTS**

The researcher developed the system by applying ASP.NET and MySQL. The system was divided into two groups: a user and an administrator as follows:

**A. Users**

For users, this is the main page where they can select a province and limit their budget to narrow a result.

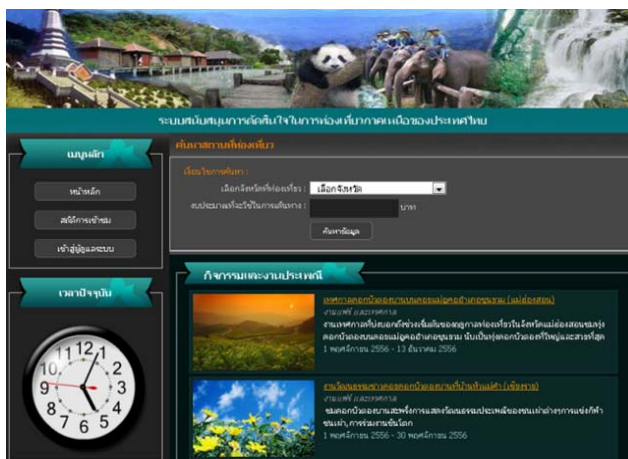

Fig. 3 System main users



Fig. 4 Analysis result

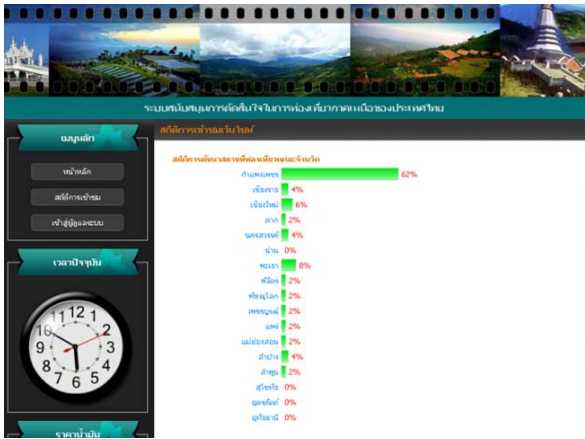

Fig. 5 Percentage of each province suggested based

B. Administrators

For administrators, after opening the system, they will see a login page. They can access to this area to modify touristic place information, an accommodation, and a restaurant.

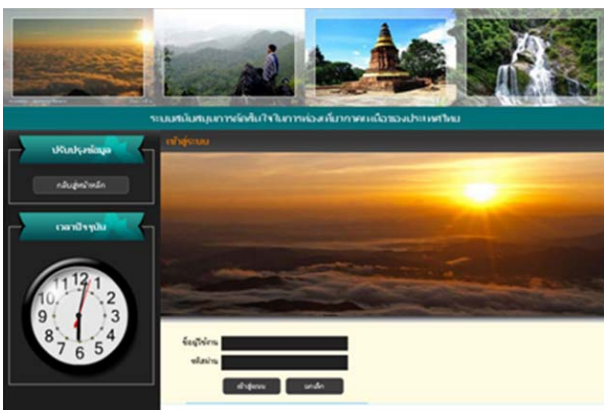

Fig. 6 System main administrator

The following picture shows a page for controlling, verifying and administrating the data used in the system.

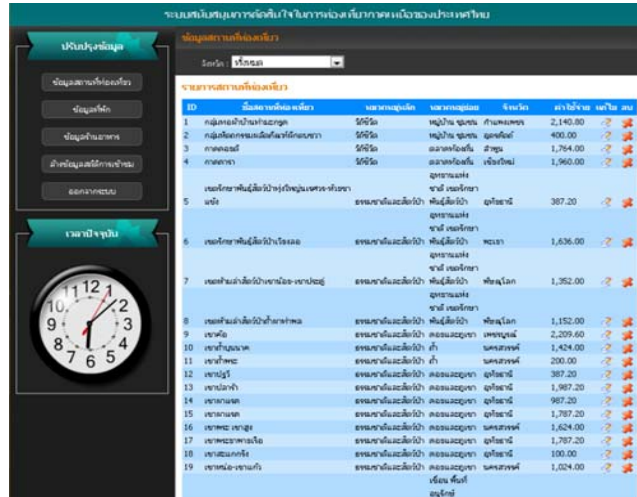

Fig. 7 Controlling, verifying and administrating

C. The Evaluation Form's Results

1) From the Experts

After analyzing the experts' evaluation, it showed that most items were rated as good, and some items were rated as moderate. There were four items for evaluation: functional requirement test's mean was 4.09 and S.D. was 0.59, function test's mean was 4.30 and S.D. was 0.61, usability test's mean was 4.14, and S.D. was 0.61, and security test's mean was 3.67 and S.D. was 0.72. It can be concluded that the experts were satisfied with the system.

2) From the Users

After analyzing the users' evaluation, it showed that most items were rated as good, and some items were rated as moderate. There were four items for evaluation: functional requirement test's mean was 4.22 and S.D. was 0.42, function test's mean was 4.13 and S.D. was 0.34, usability test's mean was 4.13, and S.D. was 0.44, and security test's mean was 4.11 and S.D. was 0.53. It can be concluded that the users were satisfied with the system.

VI. CONCLUSION AND DISCUSSION

The evaluation on effectiveness of the Decision Support System for Tourism Northern Part of Thailand by 5 experts and 30 general users are as such:

1) Experts

The experts' evaluation towards the system was at good level. The average score was 4.09 and S.D. was 0.59. This showed that they were satisfied with the system.

2) Users

For the general users, they also were satisfied with the system at the average score was 4.15 and S.D. was 0.43. This can be concluded that the developed system can respond to the users' needs and navigate on web service easily.

## VII. RECOMMENDATIONS

- 1) Besides budget input, there should be more options to input other information such as life styles, needs, etc.
- 2) The determination in touristic budget is interesting and should be added some conditions to cover the entire tourists' needs.

## ACKNOWLEDGMENT

We thank to Research and development institute, Sunanandha Rajabhat University to support in this research.

## REFERENCES

- [1] Wannika Jipipup, "The development of a decision support system for finding accommodation in Mae Hong Son Province using decision tables And creating an online map," Master of Science Central Library King Mongkut's University of Technology North Bangkok, 2010.
- [2] Phruksa. Senlueam, "Decision Support System for Planning Ecotourism Case Studies National Park in Chiang Mai," Management Information Systems Mahidol University, 2010.
- [3] Scott, R. A., "*The Massachusetts' travel and tourism industry after September 11, 2001: Behavior, perception and policy.*" Master's thesis University of Massachusetts Lowell, 2007.
- [4] Chaliaw Suksai, "*Factors affecting the decision to destinations in Chain at Province of Thailand,*" Master of Business Administration Department of Management Thepsatri Rajabhat University, 2008.
- [5] McIntosh, Robert, &Goeldner C R., "*Tourism Principles, Practices, Philosophies (6' ed.),*" New York : John WUey and Sons, 2009.
- [6] "*Tourism Authority of Thailand* ,(Retrieved December 6, 2013), available at <http://thai.tourismthailand.org/>.
- [7] NichaInjai, "*Decision support system for designing cultural-paid tour,*" Master of Arts Software Engineering Chiang Mai University, 2010.
- [8] "*ASP.NET,*" (Retrieved December 6, 2013). Available at [www.microsoft.com/thailand/msdn/ASPNET\\_MVC3\\_HTML5\\_Vol1.aspx](http://www.microsoft.com/thailand/msdn/ASPNET_MVC3_HTML5_Vol1.aspx)
- [9] "*My SQL*" (Retrieved December 6, 2013). available at [http://th.wikipedia.org/wiki/mysql.information technology](http://th.wikipedia.org/wiki/mysql.information%20technology).
- [10] Pairod Teesanatanakul & Sinton Sila, "Statistics for Research in Education," Lose media center, 2007.
- [11] Songwit. Charoenkittanalab & Team, "*Factors that affect travel decisions travel through the water of Visitors to Ayutthaya,*" Ph.D. dissertation Naresuan University, 2008.