

# Implementation of Virtual Reality in the Conceptual Design of a Tractor Trailer

Arunesh Chandra, Pankaj Chandna

**Abstract**—Virtual reality (VR) is a rapidly emerging computer interface that attempts to immerse the user completely within an experimental recreation; thereby, greatly enhancing the overall impact and providing a much more intuitive link between the computer and the human participants. The main objective of this study is to design tractor trailer capable of meeting the customers' requirements and suitable for rough conditions to be used in combination with a farm tractor in India. The final concept is capable of providing arrangements for attaching the trailer to the tractor easily by pickup hitch, stronger and lighter supporting frame, option of spare tyre etc. Furthermore, the resulting product design can be sent via the Internet to customers for comments or marketing purposes. The virtual prototyping (VP) system therefore facilitates advanced product design and helps reduce product development time and cost significantly.

**Keywords**—Conceptual design, Trailer, Virtual prototyping, Virtual reality.

## I. INTRODUCTION

IN the commercial world of specialized practice, study projects can be concerned with large scale industrial invention and even the design of entire systems, or they can alternatively result in decisive advantages for small-and-medium-sized industries by enabling their products or components to attain technical or functional dominance in the universally competitive environment. Considering the very competitive industrial context with which the companies are currently confronted, every product development must be rapid and technologically satisfactory with minimization of cost. As a result of these constraints, companies tend to under estimate aspects such as the integration of human factors, and many current products have not been designed to fulfill the end user expectations [1].

The product development process generally involves a sequence of collecting requirements, conceptual design, engineering, manufacturing and finally a market release. Successful product development depends on collaboration and communication between all stakeholders (including designers and engineers, customers, marketers or managers); throughout the phases of the developmental process. In order to achieve this support horizontal communication has been considered as one of the important tools. For instance, sketches and drawings facilitate communication between designers, CAD

models facilitate communication between engineers and the presentations or the reports are used for communication between departments. Supporting external communication (i.e. communication between people inside the development process and people outside the process) is more challenging because external stakeholders (such as end-users or customers) are usually not trained in being involved in a product development process (PDP).

However Virtual Reality (VR) can facilitate the involvement of external stakeholders in the PDP. Stakeholder involvement can improve the information quality and quantity; end-user feedback for instance facilitates concept generation and selection, or identifies usability issues at an early stage. However, with only limited design information available it is difficult to provide stakeholders with a clear presentation of a product concept and future use in context. It is therefore proposed to use VR technologies to create realistic concept representations in the early stages of the design process. VR technologies create reality in which worlds, objects and characters can be experienced that may not yet be available in reality. As such it allows stakeholders to not only see the future product (which could also be achieved with a concept sketch or mock-up), but also experience the product and the interactions with its utility.

Virtual prototyping (VP) systems have been successfully developed and used in automobile and aerospace industries. These systems can be classified into two areas, namely product design and process simulation. For product design, various analyses regarding design validation, such as functional testing, form-and-fit testing, ergonomic testing, assembly testing and disassembly testing are performed on a model in the virtual environment. Chandra and Chandna provide a systematic approach to the utilization of hand anthropometric data in VP of hand tools [2]. Bennett presented how VP could assist the different stages of product development of complex aerospace products [3]. Rooks explained the use of digital mock-ups for finding out possible errors concerning product assembly in the early design stage [4]. The parts were firstly designed in a CAD system and subsequently assembled in a virtual environment. Siddique and Rosen suggested using VP to generate complete disassembly processes of a product design [5]. For process simulation, a manufacturing process is simulated in a computer to determine possible manufacturing problems or bottle necks in production such that expensive physical mock-ups can be saved. Schulz applied VR technique to simulate the forming process of stamping products in order to study the residual stress and material distribution [6]. Bowyer et al.

Arunesh Chandra is with the Krishna Institute of Engineering and Technology, Ghaziabad- 201206, Uttar Pradesh, India (fax: 0120-2675091; email: chandraarunesh23@gmail.com).

Pankaj Chandna is with the National Institute of Technology, Kurukshetra-136119, Haryana, India (fax: 01744-238350; email: pchandna08@gmail.com).

developed a virtual milling machine that could cut a virtual block to produce a part with the desired shape by a virtual tool [7]. Bickel developed a virtual welding cell for precise weld path generation for die re-forging [8]. Apart from manufacturing, VP also has a profound impact on the medical field. It was used in training, surgical planning, and creation of digital human organs [9]. Virtual organs were created according to the patient's data for subsequent simulations. During surgical education, students could 'fly' inside and around the organs, which responded like real ones to operations. They could thus practise surgeries and other medical procedures.

Using virtual prototypes and simulation techniques, often in a virtual reality (VR) system with innovative input and stereoscopic output, evaluate and improve a product design and validate its planning and manufacturing processes [10]–[15]. Through simulations, key factors such as the shape and the manufacturability of a product may be optimised without committing much to prototypes and tooling. Indeed, virtual simulation reduces the need for physical prototypes and hence minimizes tooling cost and material waste, and it allows manufacturers to “get it right the first time” and helps them deliver quality products to market on time and within budget [16].

A trailer is a vehicle without any power (an unpowered vehicle), designed to be attached to a tractor (a powered vehicle) for transporting goods and materials from liquids to dry goods to heavy equipment and vehicles. As India is one of the biggest agricultural country, very often trailers in tractors of one type or the other are being generally used from centuries for agricultural purposes, hauling materials and for building and construction. As there is no specific trailer manufacturing company so non-specialists or local manufacturers produce the trailers that fail in some way or another. Hydraulic mechanisms were prone to damage from poor operational practices, chassis failed, buckets cracked etc. The main objective of this study is the design of a trailer capable of manual loading operations and suitable for rough road conditions which is to be used in combination with an agricultural tractor. Keeping in mind the above-mentioned problems of a typical Indian trailer, the trailers are specifically designed for the use in support of labour-based technology, ease of local manufacturing, compatibility with the commonly-available agricultural tractors, adapt to rough site conditions and ease of maintenance. Purpose of this study is to eliminate the few problems generally faced while driving a trailer. They are classified as- pin type arrangement for attaching the trailer to the tractor, weak hydraulic pickup hitch, and load bearing capacity of the frame.

## II. MATERIALS AND METHODS

### A. Existing Trailers

This study was conducted in the western region (Ghaziabad District) of Uttar Pradesh state of India. The design shown in Fig. 1 is used as a conventional design from many years for the agricultural and haulage purposes. As there are, no

manufacturing standards adopted for the manufacturing of a trailer (trolley) so it is being manufactured by local manufacturers with slight changes in the basic design as per their varying needs, in almost every region of India; whether it is a village, town, or a city. Often used in conjunction with powered machinery and equipment, trailers, carts, and wagons are hitched to tractor and equipment. Sometimes with the use of a simple hitch or with devices those are more complex. Farmers use haulage equipment in conjunction with combine harvesters, tractors, and other equipment capable of loading or in applications that require the loading of materials (Fig. 2).

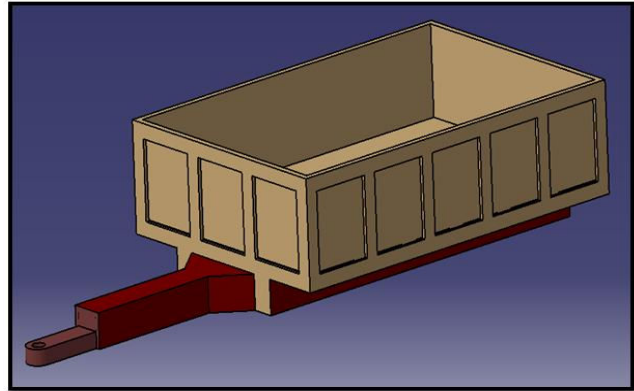

Fig. 1 Virtual Prototype of conventional (existing) trailer design

Trailers in India are available in various lengths, widths, configurations, and classes. The box type trailer- a common type of trailer is completely enclosed, allowing for goods and materials to be hauled. A flat bed trailer features an open deck so goods and materials can be stacked up. Most other types of public trailers available in Indian markets are: van trailer, beam trailer, bottom/center dump trailer, cattle trailer, chip trailer, combination trailer, curtain side trailer, end dump trailer, equipment trailer, flatbed trailer, lowboy trailer, pneumatic bulk trailer, pole trailer, pup trailer, roll off trailer, side dump trailer, tank trailer and vacuum trailer.



Fig. 2 Trailer as haulage equipment (Conventional trailer)

### B. Customer Needs

The first step of the process is the collection of the most important customer needs through a questionnaire based on the Likert scale [17]. The Likert questionnaire comprises of several statements, each of which the respondent has to assign a value corresponding to his level of agreement. So that is possible to categorize the customer requirements based on the importance given by the respondents [18]. The survey provides a better understanding of what customers' want and helps the designer to focus on the most important product attributes to be improved [19]-[23]. The first step of the study was the identification of a set of needs related to operations involving a tractor-trailer combination. The list of requirements was developed starting with interviewing experts in the field. The topics included provision of C-channel welding, reduction in cost, trailer adaptability to different payloads and operations, and ergonomic operations. The questionnaire was submitted to a group of 49 male residents of Ghaziabad district of locality (Guldhar, Garhi, Duhai, Muradnagar, Dasna, Indergarhi, NH-24, Pilkhuwa, Masuri etc.) involved in farming and hauling activities in the nearby region. Residents evaluated a set of 8 statements choosing their degree of adherence to each statement. Using a 5-point scale composed in this way: (1) strongly disagree; (2) disagree; (3) undecided; (4) agree; (5) strongly agree.

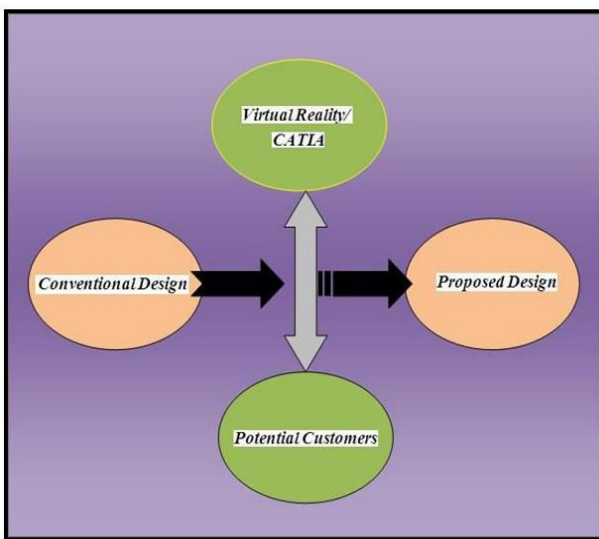

Fig. 3 Method of proposed design using virtual reality

### C. Concept Design

Inventive solutions (proposed design) shown in Fig. 3 in consultation to potential customers provided by brain storming and analysis of conventional trailer generate several product variants that can be designed in parametric CAD (CATIA) software using a top-down modeling approach. The top-down logic is a typical approach to designing a complex product, as stated by many authors [24]-[26]. Adopting the same, the designer has a complete view of the whole assembly, and it is

possible to make considerations and adjustments of the entire assembly in real time, resulting into savings of time.

### D. Concept Selection

After the evaluation of product design concepts using consumer requirements, a second qualitative evaluation is made by a group of experts (local manufacturers) to provide their opinion about the importance of each parameter, in order to fulfill consumer requirements for the product variants. Analytic hierarchy process (AHP) [27] has been used for the purpose. Participative design is important to improve quality not only in applications with industrial backgrounds, but also for non-industrial ones [28]-[30]. The purpose of the participative approach is to involve a group of experts to compare several alternative design solutions in order to find an optimal one with the help of an immersive VR environment [31]. The immersion in a virtual environment is important to let the expert make both an aesthetic evaluation of the concept and a functional evaluation of all the mechanisms [26]. With the help of virtual reality, it is possible to perform an interaction with the product and have a live experience of product use [32], [33]. The entire methodology is aimed at producing an optimal concept that satisfies customer requirements and adopts innovative solutions. The identification of the optimal concept ends the concept design process.

## III. RESULTS AND DISCUSSIONS

After the survey analysis, in which a mean score for each sentence was calculated, a set of requirements with a score of 4 or greater was obtained (Table I).

TABLE I  
SELECTED CUSTOMER REQUIREMENT

Mean Score	Customer requirement
4.70	Stronger and lighter supporting frame
4.55	Improved drawbar hitching arrangement
4.41	To decrease the unloading time and to ease the unloading operation
4.12	Increased load carrying capacity
4.04	Option of a spare tyre (Stepney)

A set of quality characteristics (functional requirements) of the product was identified to satisfy those needs and inserted into the top row of the table. These describe the product in measurable terms and affect customer perceptions directly. For example, one of the main customer requirements reported in Table I was "stronger and lighter supporting frame".

Once both customer requirements and quality characteristics were identified, contradictions were identified. The final evaluation phase of the best concept was carried out through an interactive design approach by the VR techniques. It involved the participation of experts in order to give weight to every quality characteristic and simulation of trailer operations considered in this step, and to obtain an overall evaluation of each concept. The instrument chosen for the decision-making process was the AHP. In the first step of the

process, the trailer selection problem was broken down into several levels identifying a set of criteria and sub-criteria [30].

The first and the foremost requirement of a trailer is its base, which serves as a skeleton supporting all its parts. The supporting frame should be capable to with stand heavy loads to ensure enough strength with optimum weight. In conventional design, although the section is capable to carry heavy loads, but its structure is quite bulky. The bulky structure (Fig. 4) not only increases the manufacturing cost but also the overall weight of a trailer. Due to the presence of a variety of manufacturers in each region, a new design is evolved frequently, but still the weight factor imposes a major problem, which increases the manufacturing cost and also the overall weight of the trailer. The basic purpose of design team is to provide a frame with reduced weight and improved load carrying capacity without increasing the overall manufacturing cost. Thus a new structure based on the design is recommended by [34]. Trailer was designed on VR as shown in Fig. 5 which is not only less in weight but also having enough strength to with stand heavy loads.

The proposed design offers following advantages over existing design: three-point support is provided in the proposed design, rather than the conventional two-point support, cross arms are provided in the proposed design, which gives an extra support to the structure rather than the conventional bunch of arms. Lighter channel sections are provided in the proposed design, which reduce the overall weight and thus the manufacturing cost. Continuous welding is being provided in the proposed design rather than the conventional discrete welding, long angular sections are provided, which not only enhances the supporting strength but also join the end sections with the middle drawbar. In conventional (existing) design a pin and eye type hitching (drawbar) arrangement is presented in Fig. 6. The proposed arrangement is designed to have an easy assemblage of the trailer drawbar and the tractor. A cylindrical shaped pin is used with a hook on its upper side for easy grasping, and an eye at the bottom for locking. A clevis pin is used to lock the cylindrical shaped pin to avoid its lifting up in case of bumping.

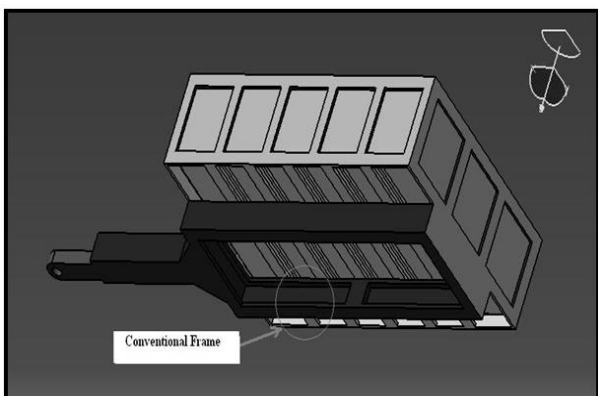

Fig. 4 Conventional (existing) Frame

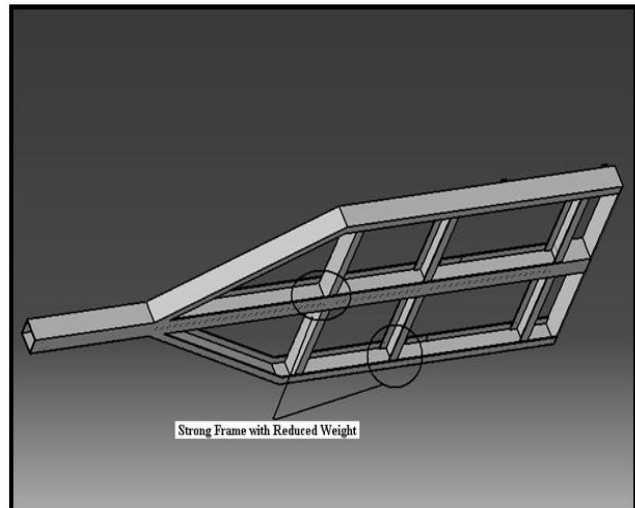

Fig. 5 Proposed frame

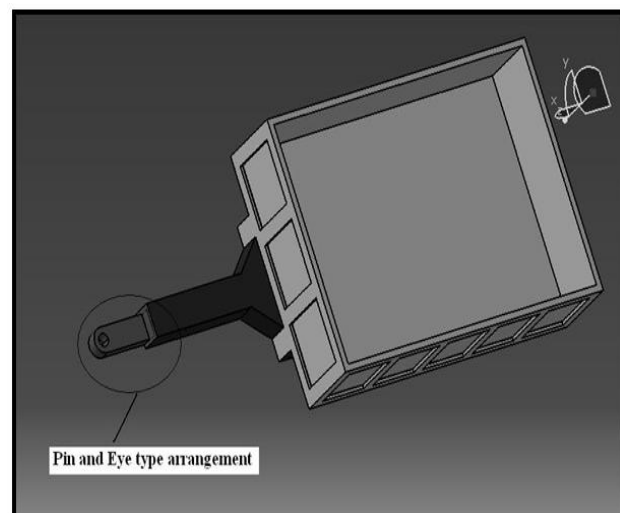

Fig. 6 Conventional (existing) pin and eye type arrangement

However, one of the major difficulties for operators of mechanical haulage units is the arrangement for attaching the trailer to the tractor. The nature of the haulage operation necessitates constant hitching and unhitching of the trailer and travel over rough sites. On some agricultural tractors, the socket hitch does not allow any vertical adjustment during hitching and unhitching. It is therefore not a practical choice when trying to align a fully loaded trailer whose drawbar is resting on the ground. Due to lack of commercial options in conventional design, for a heavy-duty hitch, is required change in design which is proposed through VR. The proposed change (Fig. 7) is robust, simple, and is adaptable to a wide range of tractors models and types (manufactures). In the proposed design two double sided pins are used which provides four sided locking to attach a trailer's drawbar with the tractor.

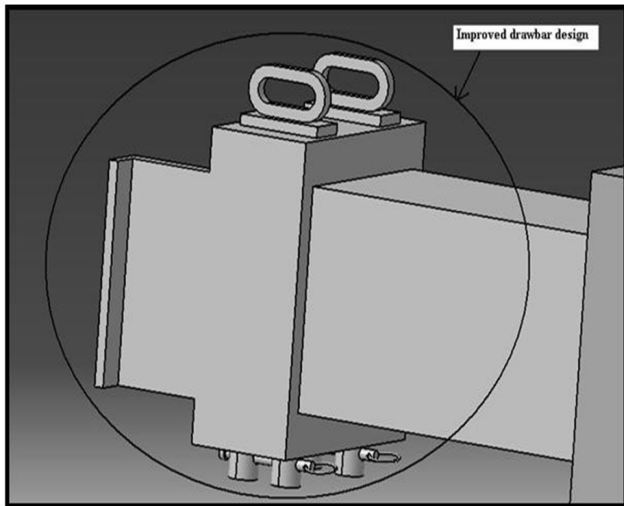

Fig. 7 Proposed double pin type arrangement

In conventional (existing) design, the unloading of the material kept in the trailer is generally done by manual labour because no unloading device is present in it. Manual unloading is a time consuming and cost effective task, which also depends upon the availability of the labour. In some cases; conventional trailers are equipped with a single hydraulic cylinder in which the unloading is done automatically without the use of manual labour. However, mostly the conventional design cannot be easily equipped with the hydraulic mechanisms, as its cylinder's stroke length is larger due to which it is very costly and bulky in appearance. To overcome the problems of a trailer equipped with single cylinder, a mechanism with two hydraulic cylinders (Fig. 8) is used in the proposed design (instead of a single bulky cylinder); which not only increases the efficiency of working but also maintains the cost within the limit. In addition, if one cylinder fails while working there is another cylinder, which will sustain the load and prevents the sudden fall of a bucket. The arrangement is working on hydraulic pressure which is controlled by the driver. The bucket is lifted up to a certain angle depending upon the stroke of the cylinders used in the hydraulic mechanism.

In proposed design, the cylinders are located at the bottom side of the trailer (Fig. 9). These two cylinders are located in such a manner that the bucket will lift up easily and very less effort is required to lift up the bucket. The cylinders are hinged up with the pins, one pin is welded at the frame and the other is bolted with the bucket. The lifting height of the trolley is based on the stroke of cylinders.

Another important concern of the customers is that many times a difficult situation arises such as bursting or puncture of tyre due to heavy load, less air etc. In these situations it is often required that tyre has to be changed, but in conventional design no spare tyre is provided. In proposed design, an arrangement is provided so that a spare tyre can be attached with the trolley at the bottom of bucket as shown in Fig. 10 considering the balancing of the trailer and to offer as an

additional advantage to the requirements of customer if any problem arises.

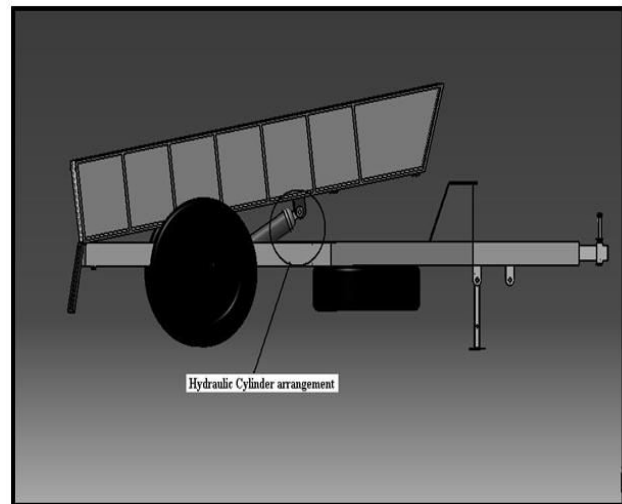

Fig. 8 Tractor trailer with hydraulic cylinders

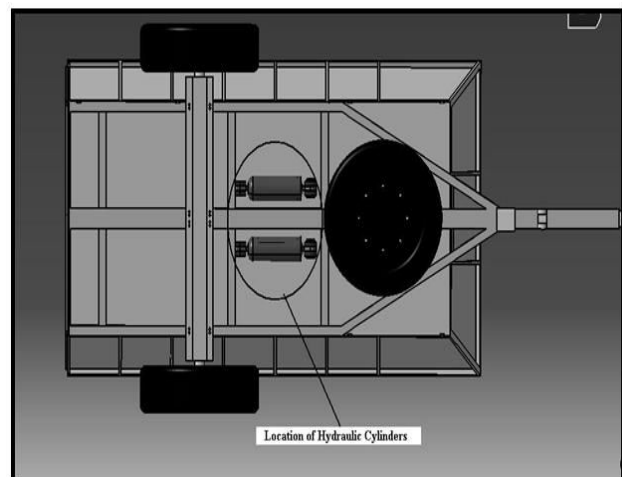

Fig. 9 Location of hydraulic cylinders

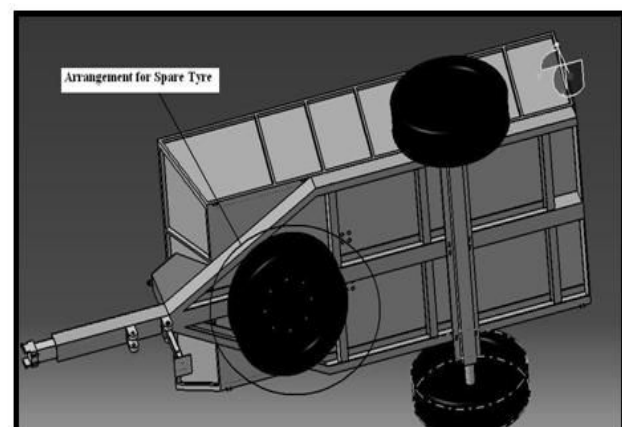

Fig. 10 Provision of spare tyre in tractor trailer

The proposed use of VR and AHP seems to be innovative in the evaluation phase. In particular, VR improves the interaction of the experts with the virtual concepts, allowing an adequate subjective evaluation. AHP allows not only evaluation of the weights of the different concepts, but also prioritization of the different quality elements. The final concept chosen seems to be suitable for the Indian customers, flexible enough for agricultural and transportation use, and cheap. As a continuation to this study, a comparison could be made with existing trailers.

#### IV. CONCLUSIONS

This research was successful in examining the challenges of applying virtual reality (VR) techniques to the interactive design of a trailer of tractor. The research shows that the product representation knowledge is an important factor for understanding represented product concepts. As the 'customer' is the end-user of a product, establishing early communication with potential customers during product development is essential to identify their needs and to achieve response on design solutions to develop a product efficiently and make it available with greater facilities. However, it is a very difficult task to represent the different aspects of a product in the early stages of its development. When the product has not yet been materialized and there is nothing to see, hold, and focus one's attention on.

Certain advantages are achieved on the proposed design over the conventional design as: stronger and lighter supporting frame, improved drawbar hitching arrangement, double sided hydraulic pick-up, and provision of a spare tyre for difficult situations. Evaluating the design on a three-dimensional immersive surround screen, virtual environment gives the designer a better understanding of how the analysis part is changed and how it interfaces with surrounding geometry. It also has the potential to facilitate collaborative work with others interested in the trailer (part) design. The discussion considers budgetary limitations, funding, and other factors.

#### ACKNOWLEDGMENTS

The authors gratefully acknowledge the support from potential customers/users for positive cooperation and local manufacturers of the national capital region of India who directly or indirectly helped us enough in fulfilling our thirst to small queries regarding trailer design and providing needful suggestions. Authors would like to acknowledge the publication developed by ASIST technical team in Harare, Zimbabwe and Nairobi Kenya for motivation to study trailer design.

#### REFERENCES

[1] L. Bennes, F. Bazzaro, and J. C. Sagot, "Virtual Reality as a Support Tool for Ergonomic – Style Convergence Multidisciplinary Interaction Design Methodology and Case Study," *Virtual Reality International Conference (VRIC 2012)*, Laval: France (2012), pp. 1-10.  
 [2] A. Chandra, and P. Chandna, "Ergonomic design of hand tool (screwdriver) for Indian workers using comfort predictors: a case study,"

*International Journal of Advanced Engineering Technology*. Vol. 2, No. 4, pp. 231-238, 2011.  
 [3] G. R. Bennett, "The application of virtual prototyping in the development of complex aerospace products," *Aircraft Engineering and Aerospace Technology*. Vol. 69, No. 1, pp. 19-25, 1997.  
 [4] B. Rooks, "A shorter product development time with digital mock-up," *Assembly Automation*. Vol. 18, No. 1, pp. 34-38, 1998.  
 [5] Z. Siddique, and D. W. Rosen, "A virtual prototyping approach to product disassembly reasoning," *Computer Aided Design*. Vol. 29, No. 12, pp. 847-860, 1997.  
 [6] J. Schultz, "Technology transfer through prototypes," *Communications of the ACM*. Vol. 39, No. 9, pp. 26-27, 1996.  
 [7] A. Bowyer, G. Bayliss, R. Taylor, and P. Willis, "A virtual factory," *International Journal of Shape Modeling*. Vol. 2, No. 4, pp. 215-226, 1996.  
 [8] D. Bickel, "3D real-time simulation and VR-tools in the manufacturing industry," *Virtual Reality for Industrial Applications*, Berlin: Springer (1988), pp. 123-138.  
 [9] R. Zajchuk, R. Satava, "Medical applications of virtual reality," *Communications of the ACM*. Vol. 40, No. 9, pp. 63-64, 1997.  
 [10] M. Kerttula, and T. Tokkonen, "Virtual design of multi-engineering electronics systems," *IEEE Computer* (2001), pp. 71-79.  
 [11] T. S. Mujber, T. Szecsi, and M. S. J. Hashmi, "Virtual reality applications in manufacturing process simulation," *Journal of Materials Processing Technology*. Vol. 155/156, pp. 1834-1838, 2004.  
 [12] A. Gomes, and G. Zachmann, "Virtual reality as a tool for verification of assembly and maintenance processes," *Computers & Graphics*. Vol. 23, No. 3, pp. 389-403, 1999.  
 [13] G. M. Bochenek, and J. M. Ragusa, "Study results: the use of virtual environments for product design," in *1998 Proceedings of IEEE International Conference on Systems, Man, and Cybernetics, USA*, pp. 250-253.  
 [14] M. Weyrich, and P. Drews, "An interactive environment for virtual manufacturing: the virtual workbench," *Computers in Industry*. Vol. 38, No. 1, pp. 5-15, 1999.  
 [15] H. Patel, S. Sharples, S. Letourneur, E. Johansson, H. Hoffmann, L. Lorisson, D. Saluaar, and O. Stefani, "Practical evaluations of real user company needs for visualization technologies," *International Journal of Human-Computer Studies*. Vol. 64, No. 3, pp. 267-279, 2006.  
 [16] S. H. Choi, and H. H. Cheung, "A versatile virtual prototyping system for rapid product development," *Computers in Industry*. Vol. 59, pp. 477-488, 2008.  
 [17] K. Melemez, G. D. Gironimo, G. Esposito, and A. Lanzotti, "Concept design in virtual reality of a forestry trailer using a QFD-TRIZ based approach," *Turkish Journal of Agriculture and Forestry*. Vol. 37, 789-801, 2013.  
 [18] B. Shneiderman, "Designing the User Interface: Strategies for Effective Human-Computer Interaction," 3rd ed. Reading, MA, USA: Addison Wesley Longman, Inc., 1998.  
 [19] A. Gustafsson, F. Ekdahl, and B. Edvardsson, "Customer focused service development in practice: a case study at Scandinavian Airlines System (SAS)," *International Journal of Service Industry Management*. Vol. 10, No. 4, pp. 344-358, 1999.  
 [20] K. Cormican, and D. O'Sullivan, "Auditing best practice for effective product innovation management," *Technovation*. Vol. 24, No. 10, pp. 819-829, 2004.  
 [21] Y. F. Kuo, "Integrating Kano's model into web-community service quality," *Total Quality Management*. Vol. 15, No. 7, pp. 925-939, 2004.  
 [22] Y. H. Chen, and C. T. Su, "A Kano-CKM model for customer knowledge discovery," *Total Quality Management*. Vol. 17, No. 5, pp. 589-608, 2006.  
 [23] V. Kumar, R. Venkatesan, and W. Reinartz, "Knowing what to sell, when, and to whom," *Harvard Business Review*. Vol. 84, No. 3, pp. 131-137, 2006.  
 [24] K. Lee, and D. Gossard, "A hierarchical data structure for representing assemblies," *Computer Aided Design*. Vol. 17, No. 1, pp. 15-19, 1985.  
 [25] D. E. Whitney, "Mechanical Assemblies: Their Design, Manufacture, and Role in Product Development", New York, NY, USA: Oxford University Press, 2004  
 [26] G.D. Gironimo, and A. Lanzotti, "Designing in VR", *International Journal on Interactive Design and Manufacturing*. Vol. 3, pp. 51-53, 2009.  
 [27] T. L. Saaty, "How to make a decision: the analytic hierarchy process", *European Journal of Operational Research*, Vol. 48, No. 1 pp. 9-26, 1990.



- [28] F. Bruno, and M. Muzzupappa, "Product interface design: a participatory approach based on virtual reality", *International Journal of Human-Computer Studies*. Vol. 68, No 5, pp. 254-269, 2010.
- [29] S. A. Yusuf, P. Georgakis, and C. Nwagboso, "Procedural lot generation for evolutionary urban layout optimization in urban regeneration decision support," *Electronic Journal of Information Technology in Construction*. Vol. 16, pp. 357-380, 2011.
- [30] G. D. Gironimo, G. Matrone, A. Tarallo, M. Trotta, and A. Lanzotti, "A virtual reality approach for usability assessment: case study on a wheelchair-mounted robot manipulator," *Engineering with Computers*. Vol. 29, No. 3, pp. 359-373, 2013.
- [31] A. Lanzotti, G. D. Gironimo, G. Matrone, S. Patalano, and F. Renno, "Virtual concepts and experiments to improve quality of train interiors," *International Journal on Interactive Design and Manufacturing*. Vol. 3, No. 2, pp. 65-79, 2009.
- [32] G. D. Gironimo, P. Franciosa, and S. Gerbino, "A RE-CAE methodology for re-designing free shape objects interactively," *International Journal on Interactive Design and Manufacturing*. Vol. 3, No. 4, pp. 273-283, 2009.
- [33] G. D. Gironimo, S. Patalano, and A. Tarallo, "Innovative assembly process for modular train and feasibility analysis in virtual environment," *International Journal on Interactive Design and Manufacturing*. Vol. 3, No. 2, pp. 93-101, 2009.
- [34] J. Hamper, D. Mason, D. Jennings, C. Makoriwa, and D. Stiedl, "Designs and specifications for a Standard Trailer & Hitch for labour-based works," Third (revised) edition. International Labour Organisation Advisory Support, Information Services, and Training (ASIST) Nairobi, Kenya. ILO/ASIST Technical Brief No 1: Standard Trailer & Hitch pp. 1-38, 1999.

**A. Chandra** is working as an Associate Professor in the Department of Mechanical Engineering at Krishna Institute of Engineering and Technology, Ghaziabad, Uttar Pradesh, India. He obtained his B.Tech. degree in Mechanical Engineering from Govt. College, Satna, Madhya Pradesh (India) in 2000, M. Tech. degree in 2003 from National Institute of Foundry and Forge Technology, Ranchi, Jharkhand (India). He has submitted his doctoral thesis in the Department of Mechanical Engineering of National Institute of Technology, Kurukshetra, Haryana (India) in the area of ergonomics. He has more than fifteen research papers in International/National journals and conferences to his credit.

**Dr. P. Chandna** is presently serving as a Professor in the Department of Mechanical Engineering at National Institute of Technology, Kurukshetra, Haryana, India. He has more than fifty research papers in International/National journals and conferences to his credit. He has presented papers in several conferences including Australia, USA, Canada, Dubai, France, Malaysia and India. His current research interest areas include sequencing & scheduling, ergonomics, energy management, inventory management, CAE, machine learning etc.