

Cutting Tools in Finishing Operations for CNC Rapid Manufacturing Processes: Experimental Studies

M. N. Osman Zahid, K. Case, D. Watts

Abstract—This paper reports an advanced approach in the application of CNC machining for rapid manufacturing processes (CNC-RM). The aim of this study is to improve the quality of machined parts by introducing different cutting tools during finishing operations. As the cutting is performed in different directions, the surfaces presented on part can be classified into several categories. Therefore, suitable cutting tools are assigned to machine particular surfaces and to improve the quality. Experimental studies have been carried out by fabricating several parts based on the suggested approach. The results provide further support for implementing this approach in rapid machining processes.

Keywords—CNC machining, End mill tool, Finishing operation, Rapid manufacturing.

I. INTRODUCTION

OVER the years, CNC machines have been widely used in manufacturing industries to produce various kinds of parts. Previous studies have exploited the potential of this technology for implementation in a rapid manufacturing environment. A distinct approach proposed the use of an indexable device to clamp a cylindrical workpiece and allow 4-axis machining. This method allows cutting take place from several directions without refixturing workpiece until machining is completed. Furthermore, it also constrains several cutting parameters so that planning tasks are minimized. Therefore, machining can be carried out in a rapid manner and high quality produced. Unlike other rapid manufacturing (RM) processes, CNC machines are capable of cutting material at very fine cutting depths and thus minimize the stair case effect on the part. This is a prominent factor that established machining processes as reliable RM tools.

In rapid manufacturing processes, the quality of finished parts has become a major concern to meet specific operation requirements. Particularly in production engineering, surface finish is an important criterion that will directly influence the functionality of parts and costs of manufacturing [4]. Basically, an earlier method executed two machining operations in one cutting orientation. These included roughing and finishing operations. The orientations were defined through visibility analysis that aimed to completely shape the

parts with the minimum number of orientations set whilst abiding several machining rules. Rough cuts are performed to remove the bulk of the material and are followed by finishing operations that machine all surfaces visible in a particular orientation. Next, the same operations sequence is repeated on other orientations until the part is completely machined.

In terms of tool planning, the method utilized a universal approach in selecting cutting tools for machining operations. The process operated in a feature free nature without any knowledge of part features. Therefore, process planning is generalized and could be carried out quickly. The cutting tool is selected based on smallest available diameter and necessary length to reach part surfaces, this being particularly true for finishing operations [9]. The visibility algorithms created analyse the part based on 2D cross-sectional slices and thus flat end mill tools are most likely to be selected. This single cutting tool approach succeeds in simplifying machining planning tasks and allows machining operations to be constructed by using similar cutting areas throughout the process.

Despite its simplicity in tool selection, this approach suffers from several drawbacks. Due to the tool tip geometry, the flat end mill is not suitable to machine free form and non-flat surfaces. Cutting these surfaces will result in a stair case affect as can be seen with common additive processes. In order to minimize this problem, machining can be executed using small depth of cuts but the effect will still remain visible on the part surface [8]. Moreover, machining time would be extended as smaller cutting levels were used. Another problem is related to accessibility of the flat end mill cutter. The study of machinability analysis using this kind of tool has disclosed the limitation in cutting the part completely [10]. The toy jack model in Fig. 1 illustrates the possible region that is not accessible to the cutting tool and this result in higher concentrations of excess volumes.

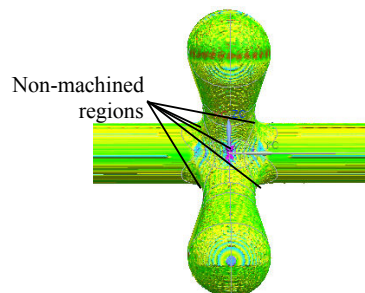

Fig. 1 Limited tool accessibility on part [9]

Osman Zahid, M.N. is a research student in Mechanical and Manufacturing Engineering, Loughborough University, LE11 3TU, UK (e-mail: m.n.osman-zahid@lboro.ac.uk).

Case, K. is Professor of CAE in Mechanical and Manufacturing Engineering, Loughborough University, LE11 3TU, UK (e-mail: k.case@lboro.ac.uk).

Watts, D. is a University Teacher in Mechanical and Manufacturing Engineering, Loughborough University, LE11 3TU, UK (e-mail: d.m.watts@lboro.ac.uk).

In the worst case, these problems could affect the quality attributes of machined parts which including surface finish and accuracy. Integrating cutting tools seem to be a practical solution to overcome the problems. So far, however, no clear methodology has been developed to guide the integration during the machining and planning phases. This paper seeks to remedy these problems by formulating a feasible approach for cutting tool selection in finishing operations. It proposes the use of different cutters based on classified surfaces and aims to improve part quality. The paper has been organized in the following way. A distinct methodology is defined after this section. It discusses how surface classification is performed within one cutting orientation. Then, simulation and machining set ups are described before starting the experiments. The results are analysed through visual inspection and roughness analysis. Finally, the overall performance is reviewed to validate the proposed approach.

II. METHODOLOGY

Formerly, finishing operations in the rapid machining approach utilized the smallest flat end mill tool to machine most of the shapes present on the part. Generalizing the operation using a single cutting tool manages to minimize the planning load and avoids any features recognition tasks. However, a major problem comes when evaluating the quality characteristics of machined parts. Integrating cutting tools during the operations has a potential to solve the issue. However, practical steps and guidelines are necessary to assist in selecting appropriate combinations.

A. Surface Classification and Cutting Tools

Fundamentally, the method developed in this study utilized two common end mill cutters to execute machining on flat and non-flat surfaces. This method is derived from previous research on generating finishing cuts on parts produced by welding operations in a layer deposition process [1]. Considering rapid machining requirements, the previous method has been modified by constraining some parameters including cutting tools and surface categories. In one cutting orientation, surfaces presented on the part can be classified into two types. Flat surfaces are defined based on the direction of the cutting tool. Any surfaces that are perpendicular to this direction are considered under this category. Then, the rest of the surfaces are directly translated as non-flat surfaces. During finishing processes, the first cutting operation utilizes a flat end mill tool to cater for flat areas. Then, a second operation covers the non-flat surfaces using a ball nose end mill. According to Fig. 2, based on the direction of cutting tool, the dark grey areas represent flat surfaces whereas the light ones are considered as non-flat surfaces. It is crucial to understand that this classification is based on cutting tool direction rather than standard surface attributes. In the example of Fig. 2 vertical flat surfaces are categorized as non-flat surfaces because they are not perpendicular to the cutting tool direction.

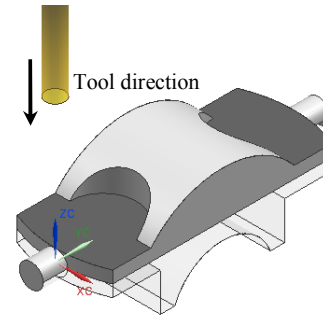

Fig. 2 Classification of flat and non-flat surfaces under one cutting orientation

The proposed approach had constrains cutting tool selection to flat and ball nose end mills. This is due to the capabilities of both tools to cater for the classified surfaces. It is proven that a flat end mill precisely machine planar areas with minimum scallop effects [6], [12]. The bottom of the tool makes full contact with a flat surface and removes material effectively. On the other hand, a ball nose end mill is selected to machine non-flat surfaces. Numerous studies have recognized the capability of this cutter to machine sculptured surfaces with minimum and acceptable roughness [2], [7], [14]. Moreover, this tool can be easily guided to engage the part and this simplifies the NC program for machining [3]. However, obvious scallop effects may be present if the cutting occurs on planar surfaces. Therefore, it is important to assign the cutting area properly during the planning stage.

In a similar way as roughing operations, the finish cuts are carried out only to the centre of cylindrical workpiece. But, if a ball nose cutter is used, cutting level is extended until the flat vertical side of the cutter reaches the centre of the workpiece. Without this adjustment, the round shape of the cutter tends to leave excess material where there are restricted access areas on the part. This defect is visualized in Fig. 3. Employing different cutting levels for a ball nose tool manages to eliminate this problem. Even it is only occurs on certain part features, the cutting level is generalized for all finishing operations that utilized a ball nose cutter.

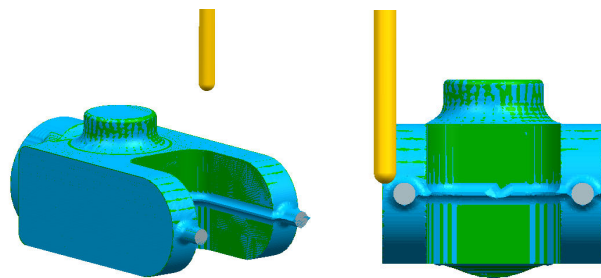

Fig. 3 Excess material left due to insufficient cutting levels

B. Simulation

In order to identify several cutting parameters, machining simulations on selected parts have been conducted. The previous work that proposed different roughing orientation

sets requires this analysis to enhance roughing operations and minimize cutting time [11]. Analyses were carried out using customised programming to construct machining operations within the NX 8.5 interface. The program accesses each possible cutting orientation and produces data on total machining time. Orientations with minimum cutting times are selected to execute roughing operations. This information is then used to build machining codes for real cutting operations that will be executed later.

The machining experiment was conducted by using two models that different in term of shapes, geometric features and size. Fig. 4 illustrates the models in cylindrical stock and consists of a crane hook (model 1) and a vehicle gear knob (model 2). Both models contain flat and non-flat surfaces in different cutting directions. There are two machining trials conducted for each model which represent different approaches. The first trial (trial 1) is based on original approach that relied on a single cutting tool and pooled roughing and finishing operations into one orientation. Meantime, a second trial (trial 2) executes rough cuts in independent orientations proposed by the simulation program and finishing operations based on visibility analysis. Comparative evaluations can be carried out between these trials and the implications identified.

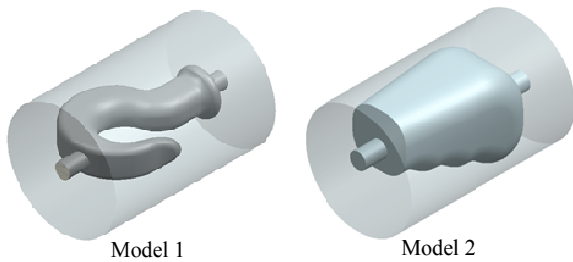

Fig. 4 Crane hook (model 1) and vehicle gear knob (model 2)

C. Machining Setups

Optimum roughing orientation sets are identified through the simulations conducted earlier. On the other hand, finishing orientations for these parts are determined based on the general rules in the visibility analysis. Certainly, the cutting must proceed from at least three cutting directions to obey the thin web avoidance rule. Then, first cutting direction is selected based on the angle that covers most of the surfaces on part [12]. As a result, the set 0° - 140° - 250° - 180° is finishing cutting orientations for model 1 and 0° - 120° - 240° was chosen for model 2. Only two set of cutting parameters were used based on roughing and finishing operations. Spindle speeds are generated automatically based on the size of the cutter used. A larger tool size is used in roughing operations and conversely, finishing operation will utilize smaller cutters. Further verification was also performed to ensure machining program developed ran accordingly. The first assessment tests the program on VERICUT® software to detect any possible defect on the part. Next, another assessment utilized the WinMax® desktop program. This is the same control software operated on a CNC Machine. After confirming the machining

program, then routine setups are performed on the machine. Fig. 5 shows the setups on a milling machine table.

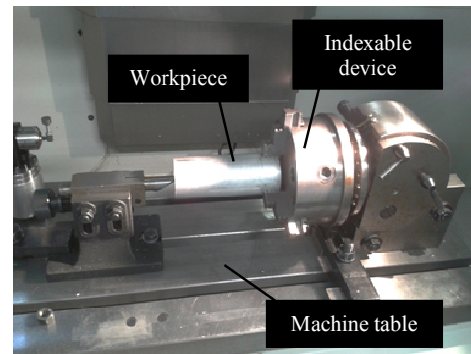

Fig. 5 Machining setups for CNC rapid manufacturing processes

III. RESULTS AND DISCUSSION

A. Optimum Roughing Orientations Set

Data collected from the simulations are compared to identify orientations that produced minimum cutting times. Table I records five minimum cutting times for model 1 and 2 and the orientation where these results were achieved. Consequently, the orientation set 181° - 271° - 11° - 91° is denoted as the optimum roughing orientations for crane hook model which took about 6 hours 15 minutes machining time. The vehicle gear knob model is fabricated in about 5 hours 51 minutes through 180° - 270° - 10° - 90° cutting directions. It is important to bear in mind that cutting times proposed in this simulation are based on a single tool approach. Later, the programs are modified to integrate multiple tools in finishing operations. Therefore, machining time predicted for trial 2 might be different from the result here.

TABLE I
OPTIMUM ROUGHING ORIENTATIONS SET FOR MODEL 1 AND 2

Model 1: Crane hook		Model 2: Vehicle gear knob	
Orientations ($^{\circ}$)	Cutting times (min)	Orientations ($^{\circ}$)	Cutting times (min)
181	374.2263	180	350.8089
270	377.1608	0	356.4803
182	378.7241	148	362.6974
180	380.7376	152	362.8327
79	381.7148	45	364.6192

B. Machining Times

The results obtained from the simulation are used as an input parameter to develop the machining program for trial 2. Meanwhile, programs for trial 1 only relied on orientations that had been decided based on part visibility. Once the developments were completed, the estimated cutting time can be extracted from the machining program. However, some variations are detected in real cutting times recorded on a CNC machine. The data in TABLE II compares the estimated and real cutting times for each machining trial. The differences ranged between 8 and 20 minutes. It is believed that the main source for this variation is due to manual adjustment of cutting parameters during the machining run. The feed rate is reduced when the cutting tool moves down

and starts to engage the workpiece. This adjustment is required to avoid sudden impact on workpiece that may cause tool failure. Hence, some operations took more time to machine the parts. After all, the estimation times are still reliable for the purpose of prediction and evaluate the efficiency of machining. On the other aspects, cutting times recorded in trial 2 are shorter compare to trial 1. Machining trials for the crane hook model utilized the same cutting parameters throughout the operations. By integrating different cutters, the machining time can be reduced further. The comparison is not applicable for model 2 as different cutting depth values were used between the trials.

TABLE II
ESTIMATED AND REAL CUTTING TIMES

Time (hour:min:sec)	Estimated time	Actual time
Crane hook (model 1)		
Trial 1	06:48:30	07:02:17
Trial 2	04:41:06	04:48:24
Vehicle gear knob (model 2)		
Trial 1	08:21:43	08:40:53
Trial 2	05:17:31	05:26:34

C. Visual Inspection

The quality of machined parts was observed visually to see the implications of cutting tools on surface finish. Fig. 6 visualizes the quality of machined surfaces on the crane hook model. Based on the observations, parts produced in trial 1 exhibit a clear stair case effect in non-flat regions. It is to be expected that this effect would be reduced by minimizing the cutting depth [9]. Therefore, trial 1 for model 2 adopted different cutting depths which were less than typically used. The step appearance was reduced but was still obvious compared to the part produced in trial 2 that used multiple cutting tools. This result signalled that using different cutting tools based on surfaces has a potential to enhance part appearance and quality.

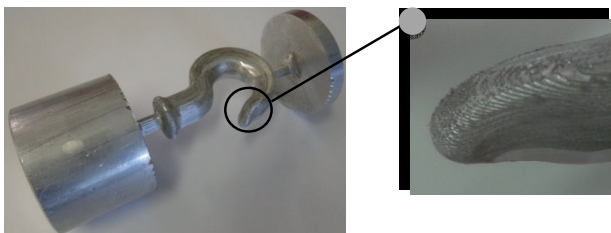

Machining trial 1

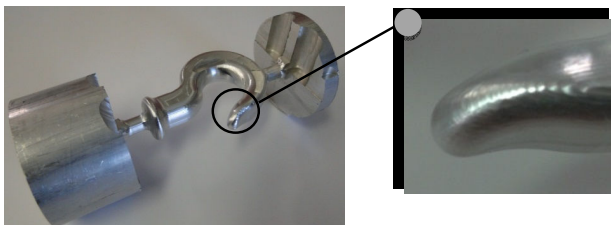

Machining trial 2

Fig. 6 Machined parts appearance

D. Surfaces Roughness

In order to verify quality characteristic on parts, roughness analyses are carried out. This is one of the established methods commonly used to determine surface quality on machined parts [13]. In this experiment, the measurements were only recorded on parts produced in machining trial 2 for both models. According to inspections carried out earlier, a stair case appearance can be seen on both models in trial 1. As the result can be predicted, roughness analyses are not performed on this trial. Meanwhile, roughness measurements are carried out using a Form Talysurf PGI 1250A produced by Taylor Hobson. The measurement parameter is the arithmetic mean average surface roughness value (R_a). This is a typical parameter that is frequently used in roughness standards. The stylus moved about 4 to 5 mm on part surfaces based on a downward direction of cutting tools to machine parts. Generally, the assessment was conducted at three locations for flat surfaces and six locations for non-flat surfaces. Later, an average R_a value was calculated based on flat and non-flat surfaces.

The average roughness values for each surface category are summarized in Table III. This table is quite revealing in several ways. Flat surfaces machined by flat end mill cutters produce better roughness values compared to non-flat areas. This signifies the advantages of the cutter to remove and smooth flat surfaces effectively. Furthermore, non-flat surfaces indicate slightly higher roughness values due to the scallop effect caused by a ball nose tool. But still, the tool is capable of getting well-engaged with this kind of surface and produces reliable results. The overall roughness result has shown acceptable part quality by integrating cutting tools in finishing operations. According to the milling roughness standard [5], the values measured are categorized as finer surface finish for this manufacturing method. The values range between 0.1 and 0.5 μm . On the other evaluation, referring to Society of Plastic Industry standard (SPI), flat surfaces achieve fine surface finish which is equivalent to SPI B surface finish. It meets typical surface requirements for plastic parts according to mould roughness classification. Based on the same standard, roughness values for non-flat surfaces are fall on SPI C surface finish that ranged between 0.2 to 0.8 μm . These roughness values are comparable to semi-smooth polishing parts. The comparison indicates that machined parts in this experiment comply with certain available standards and achieve acceptable quality level.

TABLE III
AVERAGE ROUGHNESS VALUES FOR MODELS PRODUCE ON TRIAL 2

Parts	Model 1	Model 2
Surface classification	Average R_a (μm)	Average R_a (μm)
Flat	0.1880	0.1568
Non-flat	0.4820	0.4245

IV. CONCLUSION

This paper has further verified the need for different cutting tools during finishing operations in CNC-RM processes. The purpose of the current study was to validate an approach that

suggested multiple cutting tools to machine different surfaces presented within cutting orientation. These findings suggest that, in general, the quality of parts fabricated through rapid machining can be enhanced by integrating flat and ball nose end mills in finishing operations. It was also found that cutting times are reduced by adopting this approach compared to the previous method that relied on a single cutting tool. In general, the step appearance issue that occurs with most RM processes can be minimized and eliminated by exploiting CNC machine capabilities. Beside the contribution to enhance part quality, this experimental study has also become a platform to test the program developed in assisting planning tasks. Further work needs to be done to fully integrate this approach with CNC-RM process planning. Beside, some corrections in the program are required as few problems rose while performing the operations. Classification of surfaces must be guided properly to simplify the operations development and can be executed in rapid manner.

REFERENCES

- [1] Akula, S. & Karunakaran, K. 2006, "Hybrid adaptive layer manufacturing: An Intelligent art of direct metal rapid tooling process", *Robotics and Computer-Integrated Manufacturing*, vol. 22, no. 2, pp. 113-123.
- [2] Chen, J., Huang, Y. & Chen, M. 2005, "A study of the surface scallop generating mechanism in the ball-end milling process", *International Journal of Machine Tools and Manufacture*, vol. 45, no. 9, pp. 1077-1084.
- [3] Chen, T. & Shi, Z. 2008, "A tool path generation strategy for three-axis ball-end milling of free-form surfaces", *Journal of Materials Processing Technology*, vol. 208, no. 1, pp. 259-263.
- [4] Davim, J.P. 2001, "A note on the determination of optimal cutting conditions for surface finish obtained in turning using design of experiments", *Journal of Materials Processing Technology*, vol. 116, no. 2, pp. 305-308.
- [5] Degarmo, E.P., Black, J.T. and Kohser, R.A., 2003. *Materials and Processes in Manufacturing*. 9 edn. John Wiley & Sons.
- [6] Elber, G. 1995, "Freeform surface region optimization for 3-axis and 5-axis milling", *Computer-Aided Design*, vol. 27, no. 6, pp. 465-470.
- [7] Elbestawi, M., Chen, L., Becze, C. & El-Wardany, T. 1997, "High-speed milling of dies and molds in their hardened state", *CIRP Annals-Manufacturing Technology*, vol. 46, no. 1, pp. 57-62.
- [8] Frank, M., Joshi, S.B. & Wysk, R.A. 2002, "CNC-RP: a technique for using CNC machining as a rapid prototyping tool in product/process development", *Proceedings of the 11th annual industrial engineering research conference, Orlando, Florida. May/Citeseer*, , pp. 19.
- [9] Frank, M.C., Wysk, R.A. & Joshi, S.B. 2004, "Rapid planning for CNC milling--A new approach for rapid prototyping", *Journal of Manufacturing Systems*, vol. 23, no. 3, pp. 242-255.
- [10] Li, Y. & Frank, M.C. 2006, "Machinability analysis for 3-axis flat end milling", *Journal of manufacturing science and engineering*, vol. 128, no. 2, pp. 454-464.
- [11] Osman Zahid, M.N., Case, K. & Watts, D. 2013, "Optimization of Roughing Operations in CNC Machining for Rapid Manufacturing Processes", *Proceedings of the 11th International Conference on Manufacturing Research*, Cranfield University Press, 19 September 2013, pp. 233.
- [12] Renner, A. 2008, "Computer aided process planning for rapid prototyping using a genetic algorithm", MSc. Iowa State University.
- [13] Ryu, S.H., Choi, D.K. & Chu, C.N. 2006, "Roughness and texture generation on end milled surfaces", *International Journal of Machine Tools and Manufacture*, vol. 46, no. 3, pp. 404-412.
- [14] Vijayaraghavan, A., Hoover, A., Hartnett, J. & Dornfeld, D. 2008, "Improving endmilling surface finish by workpiece rotation and adaptive toolpath spacing", *Laboratory for Manufacturing and Sustainability*.