

An Intelligent WSN-Based Parking Guidance System

Sheng-Shih Wang, Wei-Ting Wang

Abstract—This paper designs an intelligent guidance system, based on wireless sensor networks, for efficient parking in parking lots. The proposed system consists of a parking space allocation subsystem, a parking space monitoring subsystem, a driving guidance subsystem, and a vehicle detection subsystem. In the system, we propose a novel and effective virtual coordinate system for sensing and displaying devices to determine the proper vacant parking space and provide the precise guidance to the driver. This study constructs a ZigBee-based wireless sensor network on Arduino platform and implements the prototype of the proposed system using Arduino-based complements. Experimental results confirm that the proposed prototype can not only work well, but also provide drivers the correct parking information.

Keywords—Arduino, Parking guidance, Wireless sensor network, ZigBee.

I. INTRODUCTION

THE number of cars people own is still increasing nowadays due to its convenience. Therefore, parking has becoming an important requirement for people. However, finding an available parking space, especially in crowded urban areas or large parking lots is time-consuming. To support a parking assistance, most owners of parking lots or garages have used the control at the entrance via labor or electronic signboard. These methods typically provide the number of vacant spaces and the uncertain driving direction to the driver. Due to the lack of the precise information of the available space, a driver is likely to suffer from time and gasoline consumption to look for the available space. Therefore, how to design a guidance system for effective parking is becoming a crucial issue in the academic community and industry.

In recent years, the progress of the wireless and the sensing technologies creates a variety of applications, such as environmental monitoring, object detection, and security surveillance [1]. A wireless sensor network (WSN) is composed of a sink and a large or huge number of sensor nodes. Each sensor node includes a sensing unit, a processing/storage unit, a communication unit, and a power supply unit. In many applications, sensor nodes need to transmit the sensing readings (e.g., temperature, humidity, or pressure) to the sink for collection [2].

Existing studies have developed many schemes and systems to improve parking efficiency [3], [5], [6]. They mainly provide the information of the available space to drivers and achieve the management of spaces using the monitoring and communication facilities and devices. In addition to the fundamental traffic and management information provision,

many works focus on parking guidance [7], [8]. On the other hand, much research pays attention to the VANET-based parking guidance system [4], [11].

This paper proposes an intelligent WSN-based guidance system, called iPGS, for efficient parking, especially, in large parking lots. The proposed system consists of four subsystems: the parking space allocation subsystem, the parking space monitoring subsystem, the driving guidance subsystem, and the vehicle detection subsystem. The system is implemented using a WSN, which is formed by a central node and a variety of nodes, including the driving guidance (DG) node, the space monitoring (SM) node, the status indication (SI) node, and the vehicle detection (VD) node. These nodes perform their own functions and communicate with other nodes collaboratively to accomplish the guidance task. This study implements a prototype of the proposed system using the Arduino platform and a various kinds of sensor modules. All the nodes in the prototype can exchange messages with other nodes using the ZigBee wireless technology. Experimental results show that the prototype can work well, and our design can actually achieve the accurate parking guidance.

This paper is organized as follows. Section II reviews some previous work. Section III describes the proposed iPGS in detail. Section IV presents the prototype implementation and experimental results, and finally Section V provides concluding remarks.

II. RELATED WORKS

Hsu et al. [7] use the dedicated short range communication (DSRC) technology and combine many hardware and software to develop an integrated service parking guidance system in parking lots. To enhance the guidance accuracy, the system uses accelerometers and gyroscopes to correct the positioning error obtained by the global positioning system (GPS). Yoo et al. [8] design a parking guidance system on the basis of wireless sensor networks. The system consists of a vehicle detection subsystem and a management subsystem. The former gathers the information on the availability of each parking lot and report the result to the management subsystem. The latter processes the gathered information and provides the guidance information to the driver.

Lu et al. propose a smart parking scheme, called SPARK, to provide convenient parking services in large parking lots [4]. The scheme employs three roadside units (RSUs) deployed in the parking lot to monitor and manage the whole parking lot using the VANET communication technology. The main advantages of SPARK include providing real-time parking navigation service to drivers in large parking lots and friendly parking information dissemination service to the moving vehicles. Considering the large amount of investment and

S. S. Wang and W. T. Wang are with the Department of Information Management, Minghsin University of Science and Technology, Hsinchu, Taiwan (e-mail: sswang@must.edu.tw, dammy2942@gmail.com).

elaborate design of RSU-based approaches, Zhao et al. propose an infrastructureless parking guidance scheme, called IPARK, for urban areas [11]. The IPARK provides drivers two main services, including parking availability information dissemination outside the parking lot and real-time parking navigation in the parking lot. Without any infrastructure investment, the IPARK is actually a cost-effective scheme. The performance evaluation results also show that IPARK can achieve effective parking guidance.

III. PROPOSED PARKING GUIDANCE SYSTEM

Fig. 1 shows the system application scenario of the proposed system. The parking lot has only one car entrance and one car exit. These entrance and exit are at the different places. The driving lane is one-way. All parking places are regularly designed in the form of grids. Various kinds of sensing and displaying devices are deployed in the parking lot, as shown in Fig. 1.

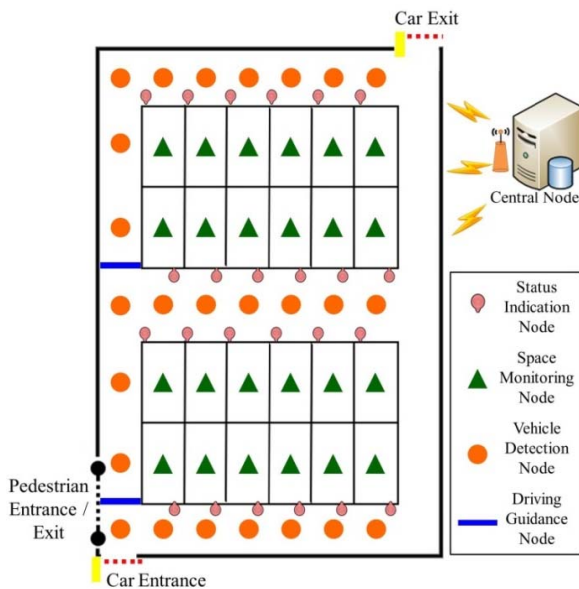

Fig. 1 Layout of the parking lot in iPGS

To avoid the influence of human behaviors on system performance, this study assumes that drivers absolutely obey the indication of VD nodes to go straight ahead or turn right. This study also assumes that drivers will enter the parking space when the SI node of this parking space turns on. Moreover, this study assumes that users walk along the roadside when they go to the pedestrian exit from the parking space.

A. Parking Space Allocation Subsystem

The parking space allocation subsystem aims to allocate the proper parking space to each car. Note that the GPS error caused by the atmospheric effect or the multipath effect is likely to occur, especially, in the indoor environment. To identify each parking space of the parking lot, this study introduces a two-dimensional virtual coordinate system. Each

parking space is represented by using an x-coordinate and a y-coordinate, as illustrated in Fig. 2. This system considers the entrance of the parking lot as the origin, and the coordinates of the origin are always all zero, denoted as (0,0). For example, the parking space marked by the red rectangle in Fig. 2 is identified by (7,4).

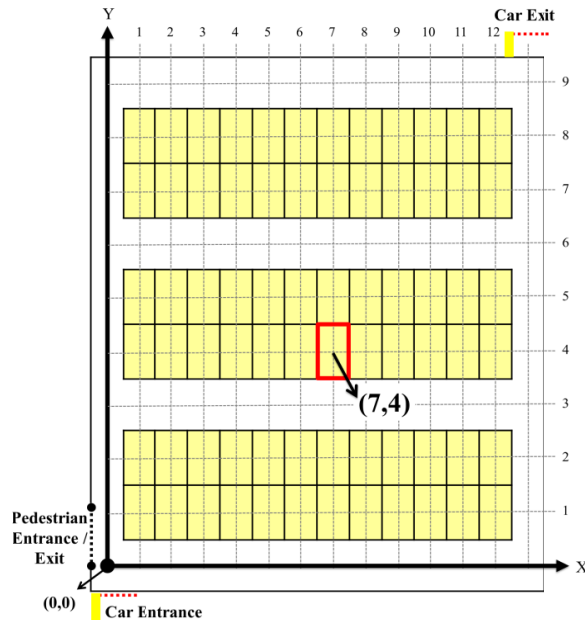

Fig. 2 Proposed virtual coordinate system

The main task in this subsystem is how to determine the best parking space for each car. This study considers the distance as the main factor to evaluate the suitability of each available parking space. Taking the requirement of most drivers into account, iPGS considers the best parking space for a car as the place satisfying that the distance between this parking place and the pedestrian exit is minimal. We call this distance the departure distance. Recall that each parking space is identified by a virtual coordinate. This study defines the departure distance of a parking space as the virtual distance between the coordinate of this parking space and the coordinate of the pedestrian exit. Let x_i and y_i be the x-coordinate and the y-coordinate of the i -th parking space. Denote d_i^{dep} as the departure distance of the i -th parking space. Given x_i and y_i , we can derive d_i^{dep} as

$$d_i^{dep} = \begin{cases} x_i + y_i, & \text{if } y_i \bmod 3 = 1 \\ x_i + y_i + 2, & \text{if } y_i \bmod 3 = 2 \end{cases} \quad (1)$$

In iPGS, the SM node will report the virtual coordinates and the status (vacant or occupied) of each parking place to the central node. The central node immediately calculates the departure distance of each vacant parking space when receiving the report message. When the central node obtains the departure distance of each vacant parking space, it selects the

parking space with the minimal departure distance as the best parking space and allocates this space to the car.

B. Parking Space Monitoring Subsystem

In general, the status of each parking space is the important information for most parking management or guidance systems. The parking space monitoring subsystem in iPGS targets to validate the existence of vehicles in a parking space and report the result to the central node. The SM node deployed in the parking space takes charge of this validation. This subsystem uses a SPACE_STATUS packet to report the status of each parking space. The occupied field in the SPACE_STATUS packet indicates the status of a parking space. The value of 0 means a vacant parking space. The value of 1 means an occupied parking space. Moreover, the SPACE_STATUS packet maintains the virtual coordinates of the sender.

Initially, all SM nodes are inactive because all parking spaces are vacant. In general, a vehicle will stop for a time period when it enters a parking space. The SM node performs vehicle detecting for a time period when detecting an object. If the SM node detects no object, it immediately returns to the vacant state, and then transmits a SPACE_STATUS packet in which the value of the occupied field is 0. On the other hand, if the duration that the SM node has successfully detected an object exceeds a threshold, it deems that there is a vehicle locating in the parking space. The node then transmits a SPACE_STATUS packet in which the value of the occupied field is 1.

C. Driving Guidance Subsystem

The main objectives of the driving guidance subsystem include driving direction guidance and parking space indication. The former is achieved by using DG nodes when cars approach the intersection of driving lanes, and the latter is accomplished by using SI nodes when cars approach the parking space allocated.

In iPGS, the DG nodes are linearly deployed and recognized by a unique identifier. For the sake of simplicity, the identifier of a DG node is denoted as a value which progressively increases with an increase in the distance between the DG node and the pedestrian exit. The iPGS allocates only one parking space per car. Obviously, only the DG node the car last passes through needs to guide the driver to turn right and other DG nodes the car has passed through need to guide the driver to go straight ahead.

Let x_a and y_a be the x-coordinate and the y-coordinate of the parking space the system allocates, respectively. Let ID^R the identifier of the DG node which needs to display 'Turn Right' indication. ID^R can be derived from

$$ID^R = \begin{cases} \frac{y_a+2}{3}, & \text{if } y_a \bmod 3 = 1 \\ \frac{y_a+4}{3}, & \text{if } y_a \bmod 3 = 2 \end{cases} \quad (2)$$

When the central node has determined the allocated parking space, it needs to notify the DG nodes to provide the guidance

information to drivers. This notification is achieved by the central node to transmit a GUIDING_INFO packet. To reduce the communication overhead, the iPGS broadcasts this packet instead of transmitting the packet to each individual DG node. Therefore, ID^R should be carried in the transmitted GUIDING_INFO packet. In iPGS, the DG node displays the indication for a specific time period, which is a pre-determined parameter. When receiving a GUIDING_INFO packet, the DG node depends on the ID^R in the received packet to determine whether it needs to turn on the accurate indication or not. The node turns off the indication when the time of indication expires.

Recall that the SM node is reasonable for reporting the status of the parking space to the central node. When the central node receives a SPACE_STATUS packet, it transmits an SI_ACTIVE packet or a CAR_ENTRY packet to the corresponding SI node if the value of the occupied field is 0 or 1, respectively. The identifier of this SI node is carried in the packet the central node transmits. When receiving a SI_ACTIVE packet, the SI node turns on the indication if it appears in the received SI_ACTIVE packet. On the other hand, when an active SI node receives a CAR_ENTRY packet, it immediately turns off its indication if appears in the received SI_ACTIVE packet.

D. Vehicle Detection Subsystem

This subsystem targets to provide the information of the vehicle's location to the central node. According to this information, the central node makes a decision of transmitting the SI_ACTIVE packet to the SI node of the allocated parking space. When a VD node detects an object, it transmits a CAR_DETECTED packet to the central node. The CAR_DETECTED packet includes the virtual coordinates of the sender.

Although depending on the notification of only one VD node is practicable for vehicle detection, it is by no means an efficient approach because the mistake may occur in that the VD node regards a non-vehicle (e.g., animal) as a vehicle. Because the movement of vehicles is closely related to time and space, this study proposes a spatial-temporal detection strategy to the improvement of detection accuracy. The main idea behind the proposed strategy is that the central node regards the vehicle is approaching the allocated parking space if it receives the CAR_DETECTED packets from k VD nodes which are near the allocated parking space within the specific time period. The value of k is an application-dependent parameter, and the study considers the value of k is 3.

IV. PROTOTYPING DETAILS AND EXPERIMENTAL RESULTS

This section presents the prototype implementation of the proposed iPGS, followed by the experimental test results.

A. Prototype Implementation

We implement the prototype of iPGS using Arduino as the platform. All the nodes in this study are implemented using Arduino UNO Rev 3 microcontroller board, based on the ATmega328 [9]. The communication module of all the nodes is

XBee ZB ZigBee (Series 2) [10]. We use the Parallax 2x16 Serial LCD (Backlit) to implement the DG node. This LCD panel can display up to two lines of text, with up to 16 characters on each line. We use the Parallax PING)))™ ultrasonic distance sensor to implement the VD node. The SM and SI nodes are implemented using the common infrared sensor and light emitting diode (LED) light sensor, respectively.

The implementation of the central node includes an Arduino board and a database. We add an XBee ZB ZigBee (Series 2) module on Arduino board. Because the central node needs to process (e.g., compare, update, etc.) the information in the received packets from other nodes, we use a laptop to create a

database to maintain the necessary information. Moreover, we use a USB to serial base unit, XBee Explorer USB, and a mini USB cable to achieve the communication between Arduino board and the laptop.

Fig. 3 shows the function block diagram of iPGS. In the central node, we design seven software modules to support the operations of the proposed subsystems. A wireless module is also included to provide the communication with other types of nodes. In addition, the central node has a database to maintain the important information, such as virtual coordinates of parking spaces, the status of parking spaces, and the location of the vehicle.

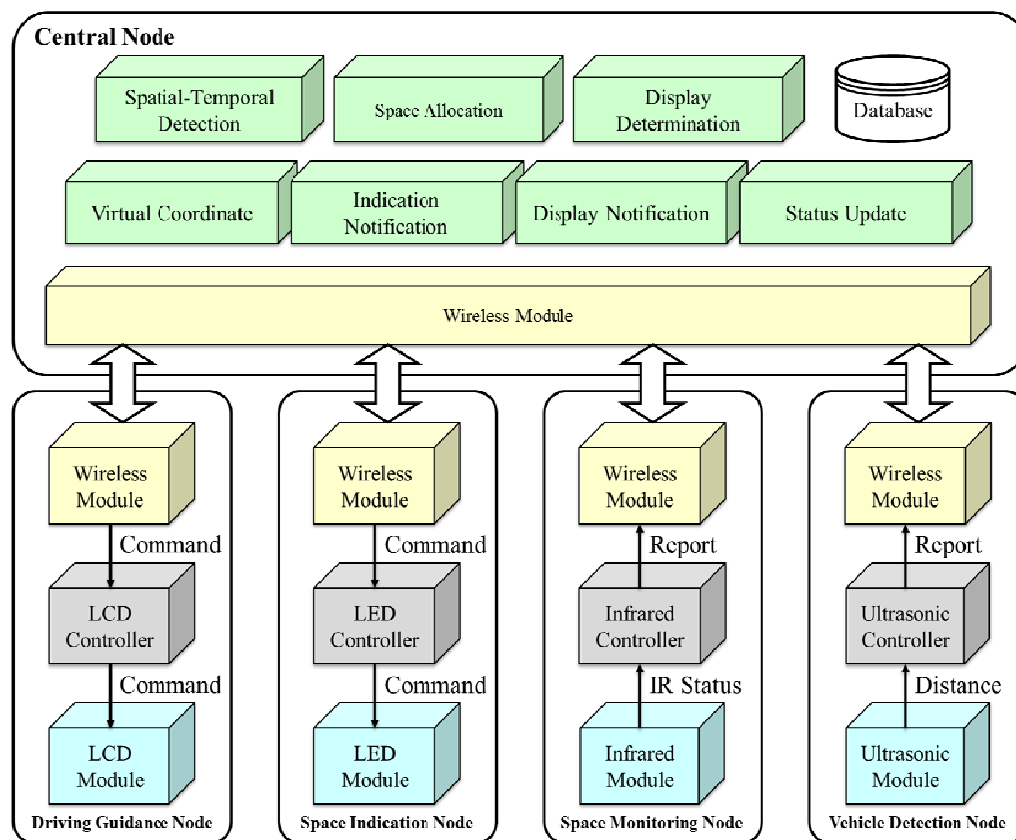

Fig. 3 Function block diagram of iPGS

To control the hardware module or communicate with the wireless module, we develop four Arduino-based software modules, including an LCD controller, an LED control, an infrared controller, and an ultrasonic control, which are implemented on the DG node, SI node, SM node, and VD node, respectively. The main functions of these controllers are as follows.

1. **LCD Controller:** This module is responsible for triggering the LCD hardware module to display the accurate indication according to the received command from the wireless module.
2. **LED Controller:** This module is responsible for turning on

or turning off the indication function according to the received command from the wireless module.

3. **Infrared Controller:** This module is responsible for receiving the infrared signals and determining the status of the parking space according to the received command from the infrared hardware module.
4. **Ultrasonic Controller:** This module is responsible for receiving the distance measurement from the ultrasonic hardware module and verifying the existence of vehicle.

B. Experimental Results

Fig. 4 shows the scenario of our experiment. We consider 24

parking spaces, which are configured as two zones and each zone is planned as a 6×2 layout. All DG nodes, SM nodes, VD nodes, and SI nodes are deployed at the specific locations mentioned in Section III. Assume the number of vacant parking spaces is 5. The virtual coordinates of these vacant parking spaces are (1,2), (1,5), (2,4), (3,4), and (5,5).

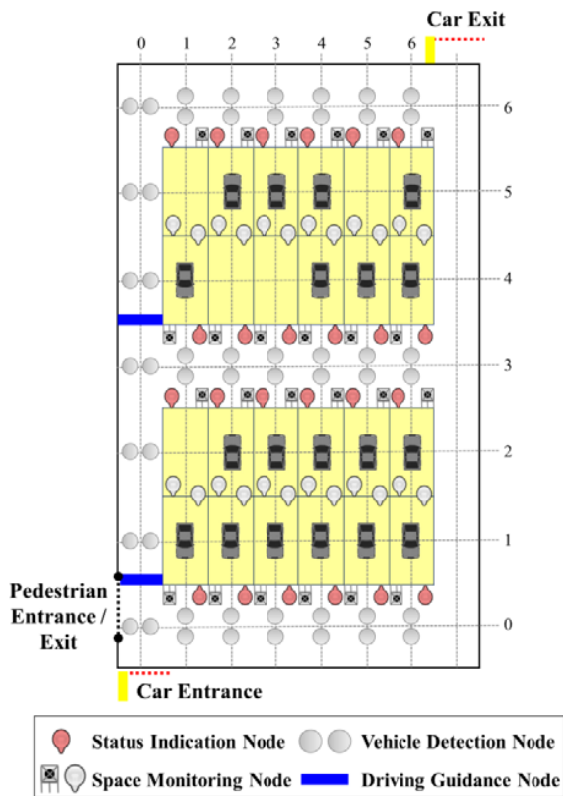

Fig. 4 Experimental scenario

Recall that when a vehicle arrives at the entrance of the parking lot, the central node calculates the departure distance corresponding to each vacant parking space according to (1). In the experiment, the central node finally allocates the parking space represented by (1,2) because the departure distance of this parking space is less than those of other vacant parking spaces. Thus, when the VD node located at (0,0) detects a vehicle, it notifies the central node of the detection result, and then the central node immediately broadcasts a GUIDING_INFO packet. Once receiving the GUIDING_INFO packet, the DG node at (0,0) displays 'Go Straight' indication, as shown in Fig. 5 (a).

When the vehicle approaches the VD node at (0,3), the DG node at (0,3) displays 'Turn Right' indication because the identifier of this DG node is in the GUIDING_INFO packet. This can be verified in Fig. 5 (b). Note that the central node can derive the coordinate of the entrance point of the allocated parking space is (1,3). When the vehicle passes through the VD nodes at (0,1), (0,2), and (0,3) in sequence, these nodes report the detection result to the central node. The central node then

requests the SI node of the parking space at (1,2) to turn on the indication according to the proposed spatial-temporal detection strategy. This can be validated in Fig. 5(c), in which the LED turns on successfully. When the vehicle enters the allocated parking space and is detected by the SM node of the parking space at (1,2), the SM node notifies the central node of this result. Then central node immediately requests the SI node of the allocated parking space to turn off the indication. The test result is shown in Fig. 5(d), in which the LED has turned off.

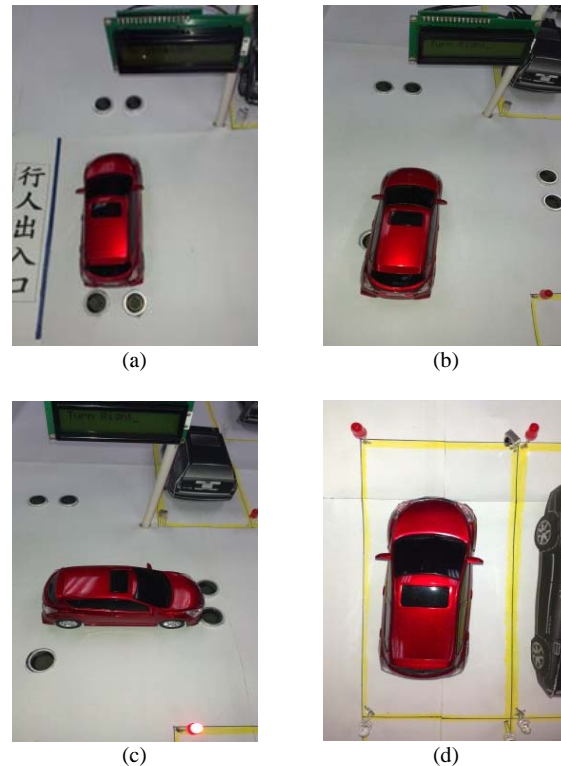

Fig. 5 Experimental results (a) The DG node at (0,0) displays the 'Go Straight' indication. (b) The DG node at (0,3) displays the 'Turn Right' indication. (c) The SI node turns on when the vehicle approaches the parking space at (1,2) (d) The SI node has turned off when the vehicle enters the parking space at (1,2)

V. CONCLUSION

This paper has proposed a prototype of an intelligent WSN-based parking guidance system, called iPGS. The iPGS includes a parking space allocation subsystem, a parking space monitoring subsystem, a driving guidance subsystem, and a vehicle detection subsystem. The nodes deployed in the parking lot perform various tasks, such as vehicle detection, parking space monitoring, and driving direction display. In addition, this study has proposed a novel virtual coordinate system to assist in determining the locations of vehicles and nodes and calculating the departure distance. Experimental results show that all nodes in our Arduino-base implementation work well, and therefore the proposed iPGS can provide drivers the accurate guidance information. Our on-going work is exploring the solution to load-balancing guidance for the requirements of

drivers when the parking lot has many exits.

ACKNOWLEDGEMENT

This work is supported by the National Science Council of the Republic of China under Grant NSC 102-2221-E-159-005.

REFERENCES

- [1] I. F. Akyildiz, W. Su, Y. Sankarasubramaniam, and E. Cayirci, "A survey on sensor networks," *IEEE Communications Magazine*, vol. 40, no. 8, pp. 102-114, Aug. 2002.
- [2] J. Ford, "Telecommunications with MEMS devices: an overview," in *Proc. Annu. Meeting IEEE Lasers Electro-Optics Society*, 2001, pp. 415-416.
- [3] Y.-Z. Bi, L.-M. Sun, H.-S. Zhu, T.-X. Yan, and Z.-J. Zuo, "A parking management system based on wireless sensor network," *ACTA Automatica Sinica*, vol. 32, no. 6, pp. 38-45, Nov. 2006.
- [4] R. Lu, X. Lin, H. Zhu, and X. Shen, "SPARK: a new VANET-based smart parking scheme for large parking lots," in *Proc. IEEE INFOCOM*, 2009, pp. 1413-1421.
- [5] V. Verroios, V. Efstathiou, and A. Delis, "Reaching available public parking spaces in urban environments using ad hoc networking," in *Proc. IEEE Int. Conf. Mobile Data Management*, 2011, pp. 141-151.
- [6] S. Mathur, T. Jin, N. Kasturirangan, J. Chandrashekhara, W. Xue, M. Gruteser, and W. Trappe, "ParkNet: drive-by sensing of road-side parking statistics," in *Proc. ACM Int. Conf. Mobile Systems, Applications, and Services*, 2010, pp. 123-136.
- [7] C. W. Hsu, M. H. Shih, H. Y. Huang, Y. C. Shiu, and S. C. Huang, "Verification of smart guiding system to search for parking space via DSRC communication," in *Proc. Int. Conf. ITS Telecommunications*, 2012, pp. 77-81.
- [8] S. Yoo, P. K. Chong, T. Kim, J. Kang, D. Kim, C. Shin, K. Sung, B. Jang, "PGS: parking guidance system based on wireless sensor network," in *Proc. Int. Symp. Wireless Pervasive Computing*, 2008, pp. 218-222.
- [9] Arduino, "Arduino UNO," <http://arduino.cc/en/Main/ArduinoBoardUno>.
- [10] R. Faludi and M. Richardson, "Basic XBee ZB ZigBee (Series 2) Chat," <http://examples.digi.com/get-started/basic-xbee-zb-zigbee-chat/>.
- [11] H. Zhao, L. Lu, C. Song, and Y. Wu, "IPARK: location-aware-based intelligent parking guidance over infrastructureless VANETs," *Int. J. Distributed Sensor Networks*, vol. 2012.