

Design and Sensitivity Analysis of Photovoltaic/Thermal Solar Collector

H. M. Farghally, N. M. Ahmed, H. T. El-Madany, D. M. Atia, F. H. Fahmy

Abstract—Energy is required in almost every aspect of human activities and development of any nation in the world. Increasing fossil fuel price, energy security and climate change have important bearings on sustainable development of any nation. The renewable energy technology is considered one of the drastic approaches which taken over the world to reduce the energy problem. The preservation of vegetables by freezing is one of the most important methods of retaining quality in agricultural products over long-term storage periods. Freezing factories show high demand of energy for both heat and electricity; the hybrid Photovoltaic/Thermal (PV/T) systems could be used in order to meet this requirement. This paper presents PV/T system design for freezing factory. Also, the complete mathematical modeling and MATLAB SIMULINK of PV/T collector is introduced. The sensitivity analysis for the manufacturing parameters of PV/T collector is carried out to study their effect on both thermal and electrical efficiency.

Keywords—Renewable energy, Hybrid PV/T system, Sensitivity analysis.

I. INTRODUCTION

THE use of solar energy conversion systems in industry is limited, but it could be broadened, mainly for the photovoltaics, if PV/T systems are used instead of the basic PV modules. In the late 1970's however, a number of studies began to investigate the incorporation of both photovoltaic and solar thermal collector into a single device [1]. These new solar systems are of practical interest for industrial applications, as they can effectively contribute to cover both the electrical and thermal industrial loads. The temperature of PV modules is increased by the absorbed solar radiation that is not converted into electricity, causing a significant decrease in their efficiency. It is well known that for mono and polycrystalline silicon PV-cells, their efficiency decreases with increasing temperature by approximately 0.5%/°C. This undesirable effect can be partially avoided by a proper heat extraction with a fluid circulation. In hybrid PV/T solar systems, the reduction of PV module temperature can be combined with useful fluid heating. There are two benefits of PV/T: firstly, the efficiency of PV cells can be increased by actively cooling them using the solar thermal collector system. Secondly, by incorporating both systems into a single unit, the area dedicated to solar energy systems can be reduced [2].

Today, industrial buildings such as freezing factories could be representing a new field that needs to both photovoltaic and

thermal solar energy conversion system. Solar energy applications in a new field related to the integration of PV and PV/T systems [3]-[5]. Freezing process is one of the oldest and most widely used methods for vegetables preservation, which allows preservation of taste, texture, and nutritional value of vegetables better than any other method [6]. The freezing process is a combination of the beneficial effects of low temperatures at which microorganisms cannot grow, chemical reactions are reduced, and cellular metabolic reactions are delayed. Washing vegetables stage with warm water is considered as one of the main stages in the frozen vegetables factories to remove chemical residue from the product.

This paper presents the design results of PV/T system used to cover both the electrical and thermal loads of a small freezing factory. The characteristics parameters of PV/T collector are calculated by means of analytical equations. The variation on the behavior of PV/T system with its parameters is presented. The results of the PV/T system design which can be used to supply both the electrical and thermal loads of a small vegetables freezing factory are discussed.

II. VEGETABLE FREEZING FACTORY DESIGN

Fig. 1 shows the layout of the suggested freezing factory. It consists of seven rooms; washing room, drying room, sterilization room, packing-weighting room, control room, pre cooling room and complete freezing room [7]. Immediately after cleaning, the vegetables are subjected to a series of washing processes. Washing is carried out generally by a flexible nozzle. The hot water is pumped from the storage tank of the collector to the nozzle. In the drying room, the vegetables are dried using dehydrated apparatus with fan. Sterilization can be achieved by ultra violet sterilization equipment where all the living microorganisms and bacterial spores are killed.

The electrical load of this equipment includes lower and upper conveyers, two ultra violet lamps, elevator and vibrating apparatus. Also, the lightning lamps of the factory are considered. There are several factors should be considered in packaging of frozen vegetables process, which include protection from atmospheric oxygen, prevention of moisture loss, retention of flavor, and rate of heat transfer through the package. Packaging is done immediately after sterilization in vacuum or in gas mixture of 20% CO₂ + 80% N₂. The control room operates the conveyor and all equipments of the factory. It includes temperature monitoring equipment and other inspection equipments. The pre-cooling room contains a

H. M. Farghally, N. M. Ahmed, H. T. El-madany, D. M. Atia, and F. H. Fahmy are with Electronics Research Institute, El-Bohous St., Cairo, Egypt (phone: 202-33310512; fax: 202-33351631; e-mail: hanaa_tolba@yahoo.com).

refrigerator which has a capacity of 500 liter. The complete freezing process is the final stage which contains two deep freezers, each of which has a capacity of 750 liter.

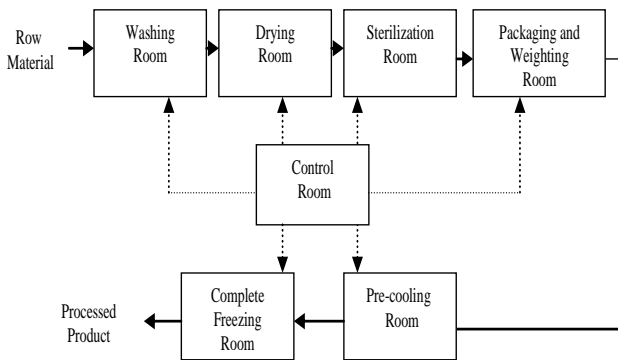

Fig. 1 Sequence of operations employed in vegetable freezing process

III. SITE CHARACTERISTICS

Kharga Oasis in the south Egypt is the chosen zone for freezing factory installation. It is the largest oasis and the capital of the New Valley Governorate in the Western Desert of Egypt. It is located about 240km southward Assiut Governorate, and about 580km away from Cairo. The latitude and longitude of Kharga Oasis are $25^{\circ} 27' N$, $30^{\circ} 32' E$ respectively.

The major economic resources for the city are tourism and agriculture since the water supply and advanced technology is available in Kharga Oasis rather than any other oasis. The most important agricultural products from Kharga Oasis are dates, rice and some vegetables. Therefore, it is preferable to install a small vegetable freezing factory in Kharga Oasis and use one of the renewable energy sources such as PV/T collector to supply both the electrical and thermal energy to this factory.

IV. ENVIRONMENTAL CONDITIONS

Kharga Oasis is known as a rich area of wind and solar energy. The available wind and solar resources greatly influence both the configuration and the cost of power system. Monthly average solar insolation and wind speed data for the selected area are shown in Figs. 2 and 3 respectively [8]. It is noticed that the highest values of the solar insolation are during the summer months (May, Jun., Jul, and Aug.) and the lowest values are during the winter months (Nov, Dec. and Jan.). The minimum and maximum ambient temperatures for our sit are shown in Fig. 4.

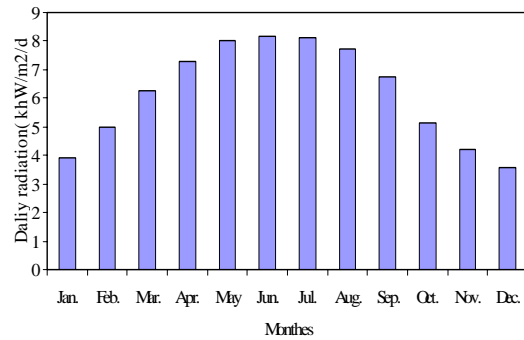

Fig. 2 Monthly average solar irradiation

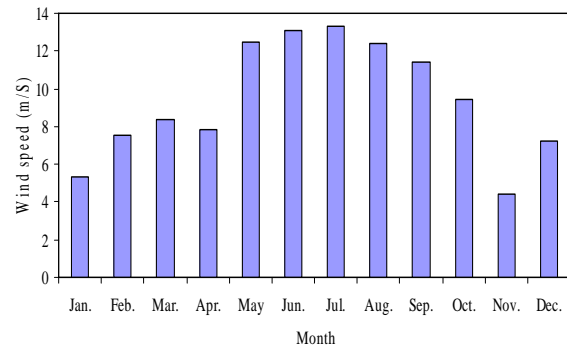

Fig. 3 The monthly average wind speed profile

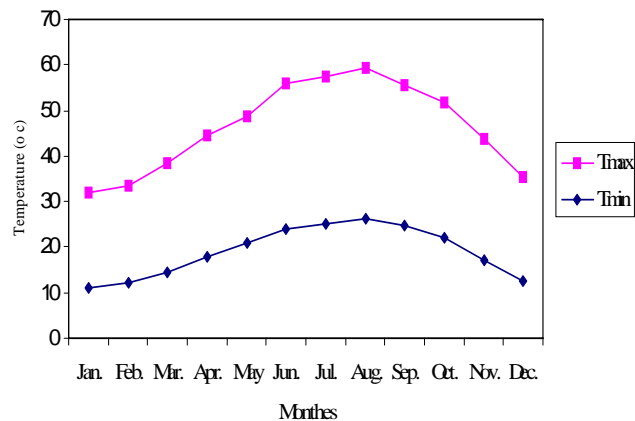

Fig. 4 The monthly maximum and minimum temperatures of Kharga Oasis

V. LOAD ESTIMATION

The electrical load profile of vegetable freezing factory is shown in Fig. 5. The thermal load calculations as follows:

The number of washing cycles for one vegetable tray = 3 with flow rate = 5 liter/ min = 300 liter/hour

The time of the first cycle = 1 min

The time of the second cycle = 3/4 min

The time of the third cycle = 1/2 min

The capacity of one vegetable tray = 10 kg

The hot water temperature for washing = 40 °C

The total quantity off vegetable produced per day = 500 kg.

The number of trays for one shift = $500/10 = 50$ trays.
 The hot water capacity = $50 \cdot (1 + 0.75 + 0.5) \cdot 5 \text{ liter/min} = 562.5 \text{ liter}$.

The capacity of hot water tank = 700 liter.
 The hot water load = $300 \cdot 20 \text{ kcal} = 6000/1.1630 \text{ kW} = 5.2 \text{ kW}$

Hence, the freezing factory requires a storage tank of capacity 700L needed for freezing 500Kg of vegetables during a day. The thermal load profile of the factory is shown in Fig. 6.

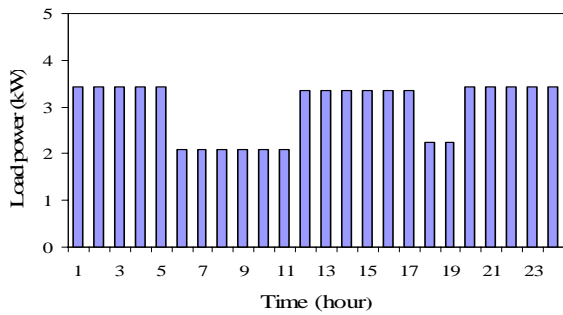

Fig. 5 The daily electrical load profile variation of freezing factory

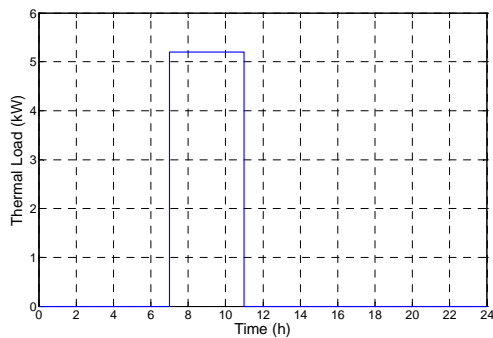

Fig. 6 The daily thermal load profile of freezing factory

VI. PV/T SYSTEM SPECIFICATION

Fig. 7 indicates the configuration of PV/T collector. In this paper, large size system (active system) with PV/T modules in parallel rows placed on a horizontal building roof with the water storage tank located inside the building and a pump for the water circulation from the collector to storage. A freezing factory power system is shown in Fig. 7. It consists of the PV/T collector, thermostatic valve, auxiliary heater to heat the water in cloudy days, a storage battery for supplying the electrical load in cloudy and night periods, and finally a controller unit which control the operation between PV/T, storage battery and the electrical load [9]. The storage tank can be located at any place, like behind the collectors, indoors in a plant room or any other suitable location, and thus, there is an overall improvement in the aesthetics of the system. The design parameters of PV/T collector used in this study are listed in Table I.

TABLE I

SPECIFICATION OF PV/T COLLECTOR CONSIDERED [9]

Parameter	Symbol	Value	Unit
Number of covers	N_g	1	
Ambient Temperature	T_a	293	K
Emittance of plate	ϵ_p	0.95	
Emittance of cover	ϵ_c	0.88	
Number of tubes	n	66	
System flow rate	m	2	lps
Collector area	A	100	m^2
Wind speed	v	2	m^2/s
PV Trans/Abs [10]	$\tau\alpha_{pv}$	0.74 or 0.78	
Thermal Trans/Abs [11]	$\tau\alpha_T$	0.925	
Absorber thickness	t	0.5	mm
PV thickness	L_{pv}	0.4	mm
PV conductivity [12]	k_{pv}	130	W/mK
Tube Hydraulic Diameters	d_h	9.7	mm
Tube spacing	w	0.1	mm
Ratio of tube width to spacing	d/w	1.5	
Heat transfer coefficient from cell to absorber [10]	$h_{pv,A}$	45	$\text{W}/\text{m}^2\text{K}$
Insulation conductivity	k	0.095	W/mK
Edge insulation thickness	L_{edge}	0.025	m
Absorber conductivity	k_{abs}	50	W/mK
Heat removal efficiency factor (typical)	F_R	~ 0.85	
Collector heat losses coefficient (typical)	U_{Loss}	~ 6 glassed ~ 22 unglassed	$\text{W}/\text{m}^2\text{K}$
Mounting angle	β	37	degree

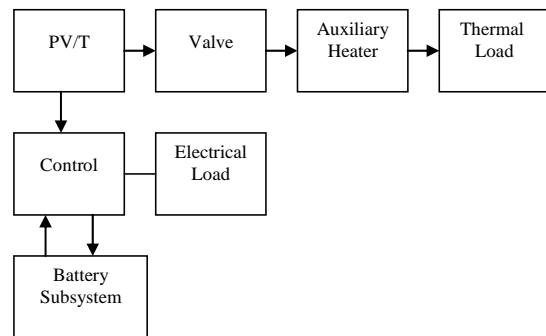

Fig. 7 Freezing factory power system

VII. MATHEMATICAL MODELING OF PVT

In order to analyze the thermal and electrical performance of the PV/T, a one dimensional steady state thermal model was developed with the collector treated as a flat plate thermal collector. As such the modified Hottel-Whillier equations presented by [13], [14] were used. The useful heat gain is represented as [9], [13]:

$$Q = AF_R [(\tau\alpha)_{PV} * GU_{loss} (T_i - T_a)] \tag{1}$$

The useful heat gain (Q) is represented as a function of the collector area (A), the heat removal efficiency factor (F_R), the transmittance-absorptance product of the photovoltaic cells ($\tau\alpha$), the solar radiation (G), the collector heat loss coefficient (U_{loss}) and the temperature difference between the cooling

medium inlet temperature (T_i) and the ambient temperature (T_a).

The heat removal efficiency factor accounts for the mass flow rate in the collector (m) and the specific heat of the collector cooling medium (C_p) which represented by [9], [13], and [17]:

$$F_R = \frac{mc_p}{AU_{loss}} \left[1 - \exp\left(-\frac{AU_{loss}F'}{mc_p}\right) \right] \quad (2)$$

In order to obtain the heat removal efficiency factor however, it is necessary to calculate a value for the corrected fin efficiency (F'). This is done by first calculating the fin efficiency (F) using [9], [13], and [17]:

$$F = \frac{\tanh(M(w-d)/2)}{M(w-d)/2} \quad (3)$$

Equation (3) determines the efficiency of the finned area between adjacent tubes by taking into account the influence of the tube pitch (w) and the tube width (d) of the rectangular cross-section tubes formed in the fabrication of the PV/T. As such all calculations related to flow in the tubes were based on the tubes hydraulic diameter (d_h).

The coefficient (M) is a term which accounts for the thermal conductivity of the absorber and PV cell and is represented as [9], [13], and [17]:

$$M = \sqrt{\frac{U_{loss}}{k_{abs}L_{abs} + k_{PV}L_{PV}}} \quad (4)$$

where: N_g is the Number of glass cover, ε_p is the Plate emittance, ε_g is the Glass emittance, T_{pm} is the Mean plate temperature, hw is wind heat transfer coefficient ($w/m^2 \text{ } ^\circ\text{C}$), v is the Wind speed (m/sec), β is the Tilt angle, p is the collector perimeter, and L is the absorber thickness.

As such, the corrected fin efficiency (F') can be calculated using [15]-[17]:

$$F' = \frac{1}{U_{loss} \left[\frac{1}{w \left[\frac{1}{U_{loss}(d+(w-d)F)} \right]} + \frac{1}{wh_{PV,A}} + \frac{1}{\pi d h_{fluid}} \right]} \quad (5)$$

where, $h_{PV,A}$ is a heat transfer coefficient to account for the bond resistance between the PV cell and the absorber and h_{fluid} is the forced convection heat transfer coefficient inside the cooling passage determined from the Dittus-Boulter equation.

$$U_{loss} = U_i + U_b + U_e \quad (6)$$

The top loss coefficient (U_i) is calculated as [9], [13], [17]:

$$U_i = \left[\frac{N_g}{C} + \frac{1}{hw} + \frac{\sigma(T_{pm}+T_a)(T_{pm}^2+T_a^2)}{(\varepsilon_p+0.0059N_ghw)^{-1} + \frac{2N_g+f-1+0.13\varepsilon_p-N_g}{\varepsilon_g}} \right]^{-1} \quad (7)$$

where:

$$c = 520(1 - 0.00005\beta^2) \quad (8)$$

$$e = 0.43 \left(1 - \frac{100}{T_{pm}} \right) \quad (9)$$

$$f = (1 + 0.089hw - 0.1166hw\varepsilon_p)(1 + 0.07866N_g) \quad (10)$$

$$hw = 5.7 + 3.8v \quad (11)$$

The bottom loss coefficient is calculated as [9], [13], [17]:

$$U_b = \frac{K_b}{L_b} \quad (12)$$

The edge loss coefficient is calculated as [9], [13], [17]:

$$U_e = \frac{(UA)_{edge}}{A_e} \quad (13)$$

$$(UA)_{edge} = \frac{K_e}{L_e} \cdot p \cdot L \quad (14)$$

The mean plate temperature can be calculated by [9], [13]-[17]:

$$T_{pm} = T_i + \frac{Q_u / A_e}{F_R U_L} (1 - F_R) \quad (15)$$

The electrical efficiency of PV/T system can be calculated based on the difference between the mean temperature (T_{pm}) of the PV/T and the Nominal Operating Cell Temperature ($NOCT$). The electrical efficiency of PV/T system can be calculated as [9], [13], [17]:

$$\eta_e = 0.15(1 - 0.005(T_{pm} - NOCT)) \quad (16)$$

The thermal efficiency of the PV module can be expressed in terms of the inlet temperature T_i , the ambient temperature T_a , and the incoming solar-irradiation on the collector surface G . The thermal efficiency of the PV/T can be represented by [13] - [17]:

$$\eta_{thermal} = F_R(S \times \tau\alpha_{PV}) + (1 - S \times \tau\alpha_T) - F_R U_{loss} \frac{T_i - T_a}{G} \quad (17)$$

VIII.SENSITIVITY ANALYSIS

Several parameters affect PV/T performance such as optimum mass flow rate, absorber plate parameters (i.e. tube spacing, tube diameter, and fin thickness), absorber to fluid thermal conductance and configuration design types. A MATLAB/SIMULINK model which is shown in Fig. 8 is carried out to determine how some of these parameters would affect the thermal efficiency of the system. The dependence of thermal efficiency on the ratio of temperature difference between the collector inlet and the ambient ($T_i - T_a$) relative to the global solar radiation incident on the collector surface (G) is carried out at various PV/T parameters. This allows us to determine the parameters that have the greatest influence on the PV/T performance, and to provide an insight into what gains could be made by changing them.

Fig. 9 describes the variation of thermal efficiency with $(T_i - T_a)/G$ for different values of fin ratio (d/w). It is observed that, as the value of d/w increase (decreasing w) the thermal efficiency increase. Also, it is found that as the value of d/w increase, there is a minimal increase in electrical efficiency which is shown in Fig. 10. This variation can be attributed to the increase of absorber collector area and a more reduction of the PV module temperature. The gap of spacing (w) between the tubes plays an important role in design configuration. Therefore, to obtain a good performance a full covered surface area by absorber collector underneath the PV module is recommended.

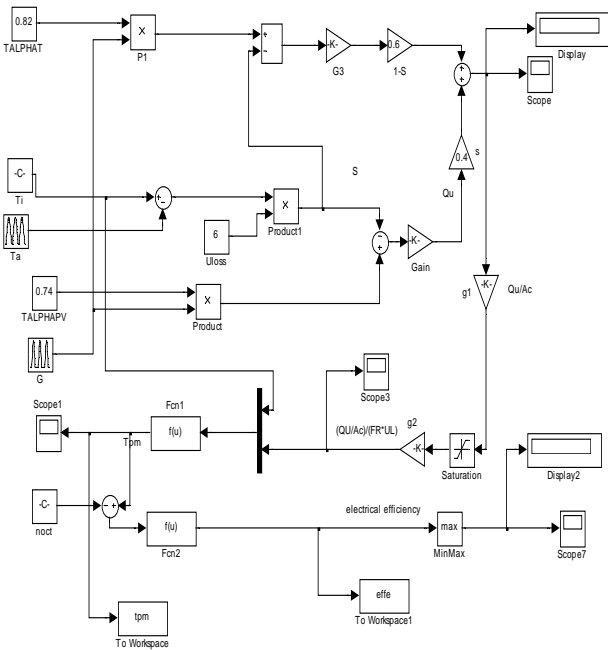

Fig. 8 PV/T collector diagram using MATLAB/SIMULINK

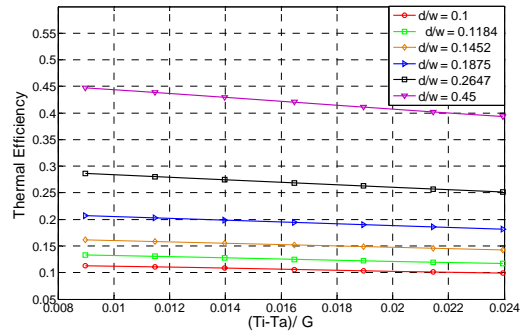

Fig. 9 Thermal efficiency variation with fin ratio

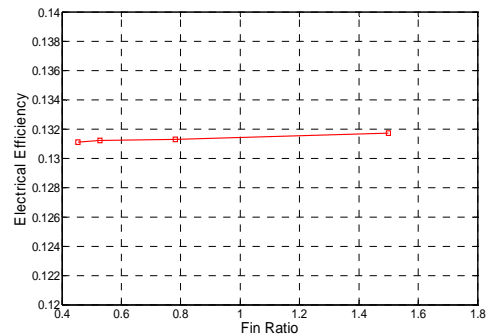

Fig. 10 Electrical efficiency versus fin ratio

One of the key parameters that affects on the PV/T performance is the transmittance/absorptance product. Fig. 11 indicated that, increasing the transmittance/absorptance product improves the thermal efficiency. Typically, silicon PV cells are designed to maximize their absorption of wavelengths where the photoelectric effect occurs in the solar spectrum ranged from 400nm up to approximately 1200nm, since the solar spectrum continues to approximately 2500nm. These long wavelengths tend to be reflected whereas they are absorbed by solar thermal collectors resulting in the increase of thermal efficiency. One of the drawbacks of increasing the absorption of longer wavelengths is that it tends to result in the PV cell temperature being increased thus resulting in a decrease in the electrical efficiency.

The thermal and electrical efficiencies versus packing factor are shown in Figs. 12 and 13. A rise in the packing factor means more collector area is covered by the PV cells. Hence, the thermal efficiency decreases along with the increase in the packing factor. However, the electrical efficiency slightly enhanced by the increment in the fraction of absorber plate area covered by the solar cells and reducing the temperature of the PV/T by withdrawing the thermal energy associated with the PV module.

Thermal efficiency versus absorber conductivity is depicted in Fig. 14. It is observed that, the thermal efficiency is decreased from 0.64 to 0.6 with the increment of the absorber conductivity; this variation can be attributed to the heat removal factor. Unlike, the electrical efficiency remains approximately 13% with absorber conductivity as shown in

Fig. 15. Therefore, the electrical and the thermal efficiency do not considerably influenced by the material from which the collector is made.

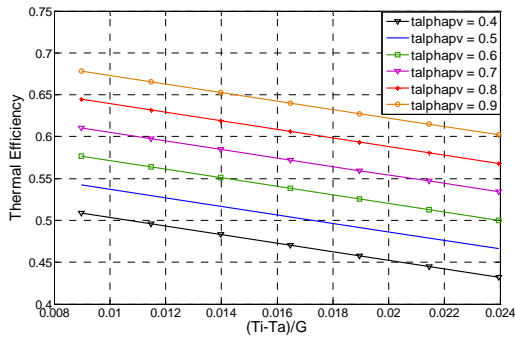

Fig. 11 Thermal efficiency variation with PV Transmittance/absorptance product

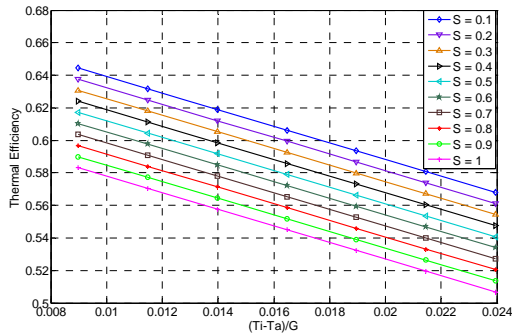

Fig. 12 Thermal efficiency variation with packing factor

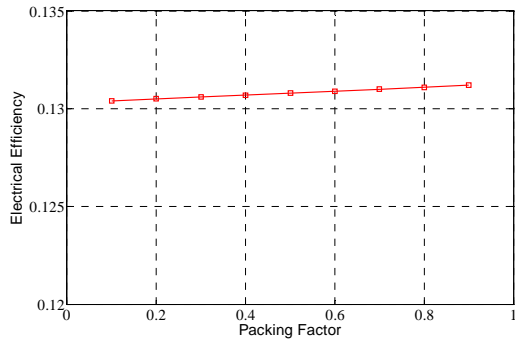

Fig. 13 Electrical efficiency versus packing factor

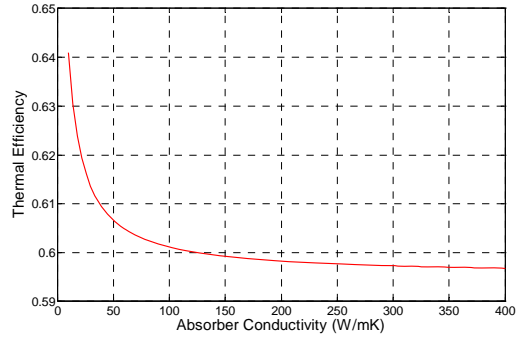

Fig. 14 Thermal efficiency variation with absorber conductivity

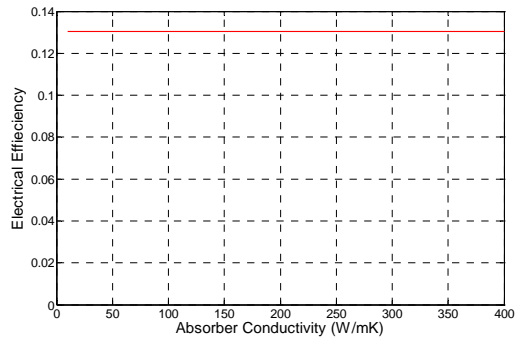

Fig. 15 Electrical efficiency versus absorber conductivity

Thermal efficiency versus heat transfer coefficient from cell to absorber is presented in Fig. 16. When the heat transfer coefficient from cell to absorber is increased up to 350 W/mK, the thermal efficiency is increased to approximately 68%. While the electrical efficiency is slightly improved with heat transfer coefficient from cell to absorber as indicated in Fig. 17.

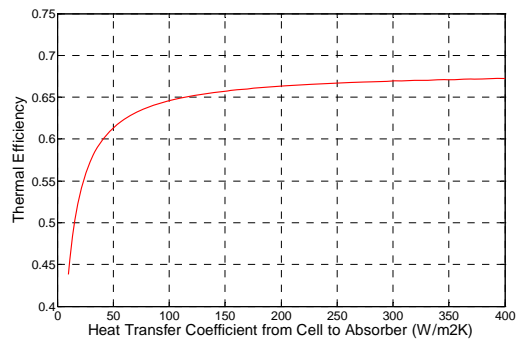

Fig. 16 Thermal efficiency variation with heat transfer coefficient from cell to absorber

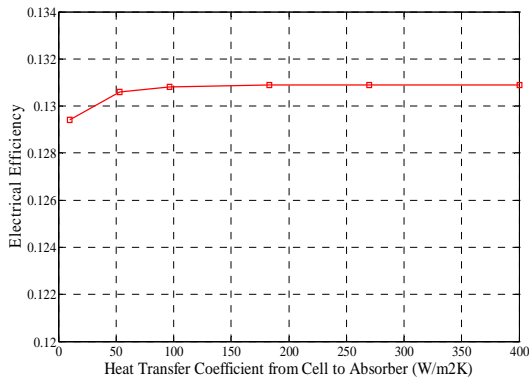

Fig. 17 Electrical efficiency variation with heat transfer coefficient from cell to absorber

One of the essential parameters which must be specified in order to achieve the most promising performance of the system is the water mass flow rate through PV/T collectors. Vividly, increasing the water mass flow rate results in more heat removal from the PV/T collector which in turn raises the electrical energy output. Figs. 18 and 19 show the variation of the thermal and electrical efficiency of the system versus the water mass flow rate respectively. As can be seen, increasing the water mass flow rate from 2 to 25 lps results in the increment in the electrical efficiency from 13.06 to 13.09% and the thermal efficiency increases from 59 to 62.5%. As can be seen, the output electrical energy from the PV panel slightly increases as the flow rate increases; this is due to the fact that the panel is working at a lower temperature.

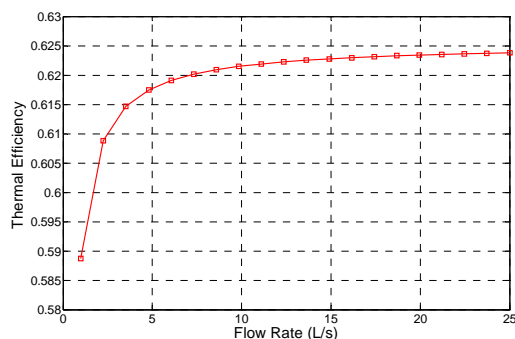

Fig. 18 Thermal efficiency variation with mass flow rate

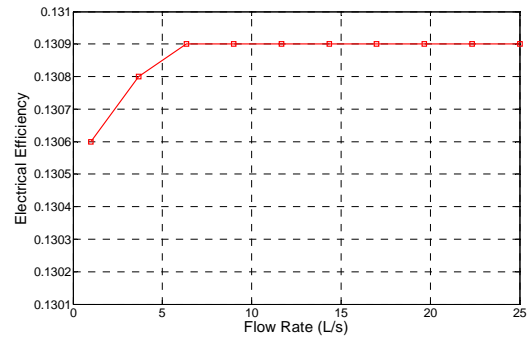

Fig. 19 Electrical efficiency variation with mass flow rate

IX. CONCLUSIONS

The solar energy conversion into electricity and heat with a single device (called hybrid photovoltaic thermal (PV/T) collector) is a good progress for future energy demand. This paper presented a PV/T collector fed a small freezing factory in a remote area in Egypt. The factory needs the electricity and hot water for operation, so using PV/T collector is promising idea. A complete design of the vegetable freezing factory is represented in this study. The factory is used for 500 Kg vegetables and a 2.975 kW electrical load. A mathematical model of PV/T collector is used to carry out multi parameters analysis and predict quite well the thermal and electrical performance of a PV/T collector using MATLAB/SIMULINK. PV/T collectors are very promising devices. If the overall energy production of the units increases, the hybrid system have better chances of success. Future work should be focused to improve the efficiency of PV/T collectors and to reduce the total cost, through this achievement, it will be more competitive.

REFERENCES

- [1] F. Jiang, T. P. Seng and G. L. Hua, "Development of Solar a-Si PV/Thermal (PV/T) System for Tropical Region", *ISES Solar World Congress*, Kassel, Germany, 2011.
- [2] S.A. Kalogeria, Y. Tripanagnostopoulos, "Hybrid PV/T Solar Systems for Domestic Hot Water and Electricity Production", *Energy Conversion and Management*, vol. 47, pp. 3368–3382, 2006.
- [3] P.G. Charalambous, G.G. Maidment, S.A. Kalogirou, and K. Yiakoumetti, "Photovoltaic thermal (PV/T) collectors: A review", *Applied Thermal Engineering*, vol. 27, pp. 275–286, 2007.
- [4] T. P. Seng, J. Fan, and G. L. Hua, "Solar Photovoltaic/Thermal (PV/T) Test-bed", in *Proc. International Congress on Informatics, Environment, Energy and Applications (IEEA) Conf.*, Singapore, vol. 38, 2012.
- [5] J. Kim, J. Chun and J. Kim, "The Experimental Performance Comparison of Two Different Types of Unglazed PV/T Collector", in *Proc. ISES Solar World Congress Conf.*, Kassel, Germany, 2011.
- [6] G. Barbosa-Cánovas, B. Altunakar, and D. Mejía-Lorío, "Freezing of Fruits and Vegetables: An Agribusiness Alternative for Rural and Semi-rural Areas", *Food and Agriculture Organization of the United Nations*, Rome, 2005.
- [7] Process Plant for Vegetables (VE00), <http://www.edibon.com/products/catalogues/cn/systems/technicalinformation/12/-VE00.pdf>, 2005, online access 2013.
- [8] New and renewable energy authority, ministry of electricity and energy, Egyptian solar radiation atlas, Cairo, Egypt, 1998.
- [9] T. N. Anderson, M. Duke, G. L. Morrison, and J. K. Carson, "Performance of A Building Integrated Photovoltaic/Thermal (BIPVT) Solar Collector", *Solar Energy*, vol. 83, pp. 445–455, 2009.

- [10] D. W. De Vries, "Design of a photovoltaic/thermal combi-panel", PhD thesis, Eindhoven University, 1998.
- [11] A. N. Weerakoon, "Use of corrugated panels as transpired solar collectors", *Unpublished PhD Thesis*, University of Auckland, 2008.
- [12] S. C. Krauter, "Solar electric power generation: Photovoltaic energy systems", Springer-Verlag, Heidelberg, 2006.
- [13] T. Anderson and M. Duke., "Analysis of a Photovoltaic/Thermal Solar Collector for Building Integration", in *proc. of SB07, New Zealand Sustainable Building Conf.*, Auckland, 2007.
- [14] G. Vokas, N. Christandonis, and F. Skittides, "Hybrid photovoltaic-thermal systems for domestic heating and cooling-A theoretical approach", *Solar Energy*, vol. 80, No. 5, pp. 607-615, 2006.
- [15] J. Duffie, and W. Beckman, *Solar engineering of thermal processes*. Wiley, New York, 2006.
- [16] W. He, T. Chow, J. Ji, J. Lu, G. Pei, and L. Chan, "Hybrid photovoltaic and thermal solar-collector designed for natural circulation of water", *Applied Energy*, vol. 83, No. 3, pp.199-210, 2006.
- [17] F. Calise, M. D. d'Accadia, and L. Vanoli, "Design and Dynamic Simulation of A Novel Solar Trigenation System Based on Hybrid Photovoltaic/Thermal Collectors (PVT)", *Energy Conversion and Management*, vol. 60, pp.214-225, 2012.

Hanaa T. El-Madany obtained her B.Sc. degree in Electronics and Communication Engineering from Faculty of Electronic Engineering, Menofia University in 2003. She completed her MSc. degree in communication engineering from Faculty of Electronic Engineering, Menofia University in 2007. She completed her Ph.D. degree in Electrical Power and Machines Engineering Faculty of Engineering, Cairo University in 2012. She is a Researcher in the Electronic Research Institute, Photovoltaic Cells Department. She published many papers in spacecraft power systems, intelligent control systems. Her interests are in renewable energy systems and their applications.