

Fuzzy Logic Based Cascaded H-Bridge Eleven Level Inverter for Photovoltaic System Using Sinusoidal Pulse Width Modulation Technique

M. S. Sivagamasundari, P. Melba Mary

Abstract—Multilevel inverter is a promising inverter topology for high voltage and high power applications. This inverter synthesizes several different levels of DC voltages to produce a stepped AC output that approaches the pure sine waveform. The three different topologies, diode-clamped inverter, capacitor-clamped inverter and cascaded h-bridge multilevel inverter are widely used in these multilevel inverters. Among the three topologies, cascaded h-bridge multilevel inverter is more suitable for photovoltaic applications since each PV array can act as a separate dc source for each h-bridge module. This research especially focus on photovoltaic power source as input to the system and shows the potential of a Single Phase Cascaded H-bridge Eleven level inverter governed by the fuzzy logic controller to improve the power quality by reducing the total harmonic distortion at the output voltage. Hence the efficiency of the system will be improved. Simulation using MATLAB/SIMULINK has been done to verify the performance of cascaded h-bridge eleven level inverter using sinusoidal pulse width modulation technique. The simulated output shows very favorable result.

Keywords—Multilevel inverter, Cascaded H-Bridge multilevel inverter, Total Harmonic Distortion, Photovoltaic cell, Sinusoidal pulse width modulation.

I. INTRODUCTION

THE demand for renewable energy has increased significantly over the years because of shortage of fossil fuels and greenhouse effect. The definition of renewable energy includes any type of energy generated from natural resources that is infinite or constantly renewed. Examples of renewable energy include solar, wind, and hydro power. Renewable energy, due to its free availability and its clean and renewable character, ranks as the most promising renewable energy resources like Solar energy, Wind energy that could play a key role in solving the worldwide energy crisis. Among various types of renewable energy sources, solar energy and wind energy have become very popular and demanding due to advancement in power electronics techniques. Photovoltaic (PV) sources are used today in many applications as they have the advantages of effective maintenance and pollution free.

Solar electric energy demand has grown consistently by 20% to 25% per annum over the past 20 years, which is mainly due to its decreasing costs and prices. This decline has

been driven by the following factors: 1) An increasing efficiency of solar cells, 2) Manufacturing technology improvements, 3) Economies of scale. [1]

The focus of the Engineers is to make use of abundantly available PV energy and so to design and control an inverter suitable for photo voltaic applications. Power electronic circuits with pulse width modulation (PWM) are mostly used in energy conversion systems to achieve closed loop control. But even updated pulse width modulation (PWM) techniques; do not produce perfect waveforms, which strongly depend on the semiconductors switching frequency. Also, it is well known that distorted voltages and currents waveforms produce harmonic contamination, additional power losses, and high frequency noise that can affect not only the load power but also the associated controller. [2]

In recent years, multilevel inverters have become more attractive for researchers and manufacturers due to their advantages over conventional three level PWM Inverters. They offer improved output waveforms, smaller filter size and lower EMI, lower Total Harmonic Distortion (THD). The three common topologies for multilevel inverters are as follows: 1) Diode clamped (neutral clamped), 2) Capacitor clamped (flying capacitors), 3) Cascaded H-bridge inverter. The cascaded multilevel control method is very easy when compared to other multilevel inverter because it doesn't require any clamping diode and flying capacitor. The diode-clamped inverter (neutral-point clamped), capacitor-clamped (flying capacitor) requiring only one dc source and the cascaded h-bridge inverter requiring separate dc sources. The latter characteristic, which is a drawback when a single dc source is available, becomes a very attractive feature in the case of PV systems, because solar cells can be assembled in a number of separate generators. In this way, they satisfy the requirements of the CHB-MLI, obtaining additional advantages such as a possible elimination of the dc/dc booster (needed in order to adapt voltage levels), a significant reduction of the power drops caused by sun darkening (usually, it influences only a fraction of the overall PV field), and, therefore, a potential increase of efficiency and reliability. [3]

Performance of the multilevel inverter (such as THD) is mainly decided by the modulation strategies. For the cascaded multilevel inverter there are several well known pulse width modulation strategies such as space vector pwm, sinusoidal pwm, selective harmonics elimination and multicarrier pwm. [4] Compared to the conventional method, the proposed

M. S.Sivagamasundari is with the Electrical and Electronics Engineering Department in V V College of Engineering, Tisaiyanvilai, India (e-mail: sreenthin@vvcoc.org).

Dr. P. Melba Mary is with the Electrical and Electronics Engineering Department in V V College of Engineering, Tisaiyanvilai, India

method is subjected to a new modulation scheme adopting the sinusoidal pulse width modulation technique which reduces the total harmonic distortion.

II. CASCADED H-BRIDGE MULTILEVEL INVERTER FOR PHOTOVOLTAIC APPLICATIONS

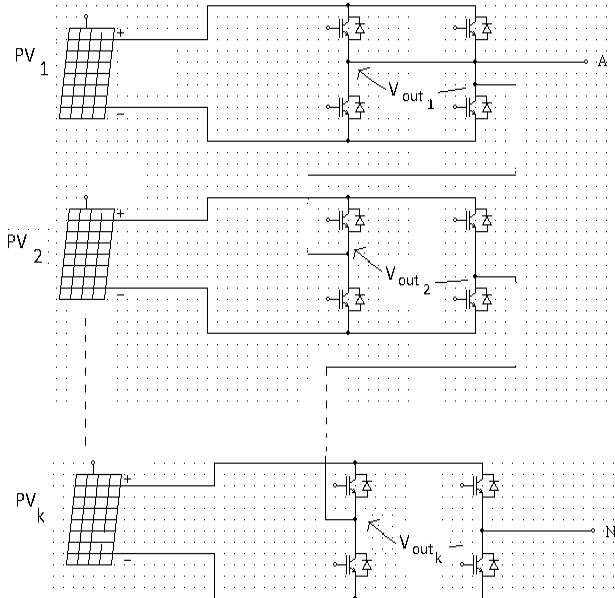

Fig. 1 Single Phase n - level Structure of Cascaded H-Bridge Inverter

Fig. 1 shows the Single Phase n - level Structure of Cascaded H-Bridge Inverter for PV applications, consisting of k dc generators and k cascaded H-bridges arranged in a single-phase multilevel inverter topology. Each dc generator consists of PV cell arrays connected in series and in parallel, thus obtaining the desired output voltage and current. H bridges basically consist of four metal oxide semiconductor field-effect transistors embedding an antiparallel diode and a driver circuit. The number k of H-bridges depends on the number $n = 2k+1$ of desired levels, which has to be chosen by taking into account both the available PV fields and design considerations. [5] Higher the number of levels the better the sinusoidal output waveforms. However, the number of level increases the complexity and the cost of the system while reducing its switching frequency in comparison with two level converters.

Since low voltage transistors (typically MOSFETs) present significantly higher switching frequency than high power transistors (typically IGBT), MLIs can operate at significantly higher switching frequencies than two level converters. This allows the use of smaller low pass filters.

Each H-bridge can be driven by a square waveform with a suitable duty cycle or a PWM pattern, thus resulting in a staircase without or with PWM [6]. In the considered single phase 230V system, the cells are arranged into five distinct arrays, thus resulting in an eleven level inverter, which can be considered a reasonable trade-off among complexity, performance, and cost.

III. CASCADED H-BRIDGE MULTILEVEL INVERTER WITH FUZZY CONTROLLER

This paper shows the potential of a Single Phase Cascaded H-bridge Eleven level inverter governed by the fuzzy logic controller using photovoltaic power source.

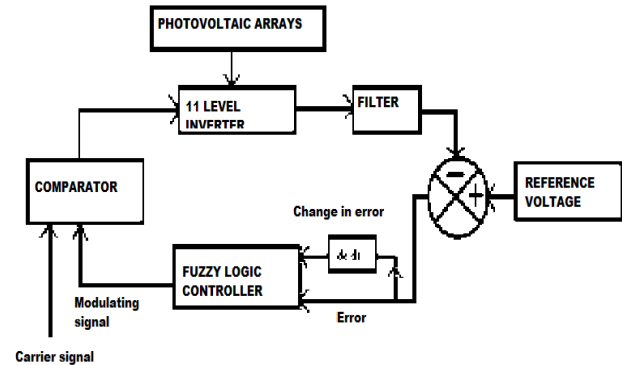

Fig. 2 Block diagram of the proposed method

Fig. 2 shows the block diagram of the proposed method. It consists of five PV arrays, the eleven-level inverter, a low-pass filter and the load. This function is substituted by a reference voltage generator imposing amplitude, frequency and phase, thus implementing a PV control strategy. Feedback signals are included in the FLC, whose outputs are continuous waveforms applied to the MLI "Driver" block which consists of conditional statement functions producing the discrete signals for gating the inverter MOSFETs.

The input variables to the FLC are as follows:

- 1) V_n , i.e., the inverter output voltage V_{out} divided by 100, measured after a low-pass filter
- 2) The difference between the actual and reference signals is $AV_{diff} = V_{out} - V_{ref}$

Inverter output voltage measured after a low-pass filter at the load terminals. This choice improves the quality of the control without introducing delays. Filter bandwidth is chosen around 1kHz with resistive load. The output of the controller is applied to the inverter gate drivers. The FLC output may assume eleven different states. The first step during the FLC design was the creation of a knowledge base, i.e., fuzzy rules, expressed in terms of statements, conditions, and actions. Starting from the condition "TRUE" (i.e., the situation is verified), a set of rules was defined for the errors. Then, conditions were defined accordingly, obtaining variable reactions. The number and type of membership functions (MFs) represent a key point for the controller. Their shape depends on the input data distribution and can influence both the tracking accuracy and the execution time.

Figs. 3 and 4 show the membership functions chosen for the two input parameters. The labels "NB," "NS," "ZE," "PS," and "PB" used for AV_{diff} stand as follows: "NB" = negative-big, "NS" = negative-small, "ZE" = zero, and so forth. The fuzzy sets for both the input and output variables were nine, as the number of levels $V-, IV-, III-, II-, I-, ZE, I+, II+, III+, IV+, V+$. A Mamdani-based system architecture

was realized; Max – Min, composition technique, and the center-of-gravity method were used in the inference engine and in the defuzzification process, respectively. In this paper, the number and type of the control rules were decided according to a sensitivity analysis made by varying the number and type of rules.

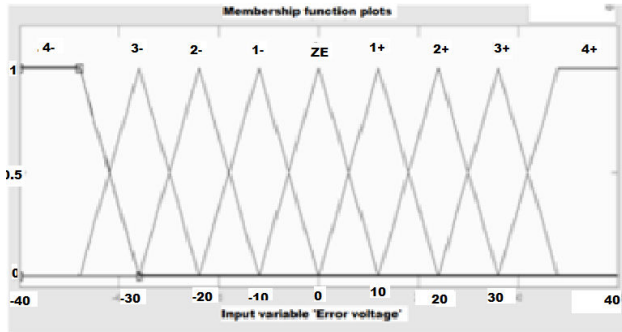

Fig. 3 Membership functions of parameter AVdiff

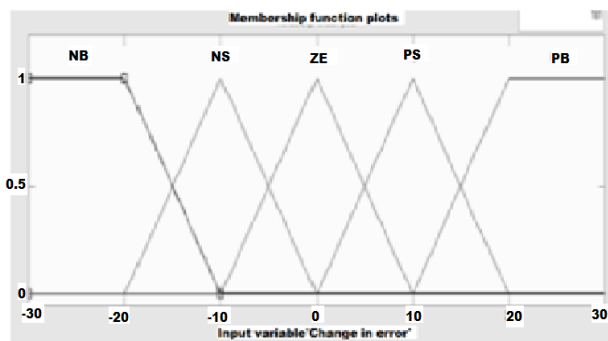

Fig. 4 Membership functions of parameter Vn.

TABLE I
INFERENCE RULES

V_n	AV_{diff}				
	NB	NS	ZE	PS	PB
IV^+	IV^+	IV^+	IV^+	III^+	III^+
III^+	IV^+	IV^+	III^+	II^+	II^+
II^+	III^+	III^+	II^+	I^+	I^+
I^+	II^+	II^+	I^+	ZE	ZE
ZE	I^+	I^+	ZE	I^-	I^-
I^-	ZE	ZE	I^-	II^-	II^-
II^-	I^-	I^-	II^-	III^-	III^-
III^-	II^-	II^-	III^-	IV^-	IV^-
IV^-	III^-	III^-	IV^-	IV^-	IV^-

The following logic was adopted for designing the inference rules:

- 1) If AVdiff is equal to ZE, the current state is correct, and the inverter conserves its current state.
- 2) Consider a generic state, if AVdiff is positive $V_{out} > V_{ref}$, then the inverter state should be reduced; if AVdiff is negative $V_{out} < V_{ref}$, the inverter state should be increased.

IV. SINUSOIDAL PULSE WIDTH MODULATION TECHNIQUE

PWM technique is extensively used for eliminating harmful low-order harmonics in inverters. In PWM control, the inverter switches are turned ON and OFF several times during a half cycle and output voltage is controlled by varying the pulse width. [7] SPWM techniques are characterized by constant amplitude pulses with different duty cycle for each period. The width of these pulses are modulated to obtain inverter output voltage control and to reduce its harmonic content. Sinusoidal pulse width modulation is the mostly used method in motor control and inverter application [8]. In order to verify the ability of the proposed multilevel inverter topology to synthesize an output voltage with a desired amplitude and better harmonic spectrum, SPWM technique is applied to determine the required switching angles. It has been proved that in order to control the fundamental output voltage and eliminate „n” harmonics, „n+1” equations are needed. Ideally, for a given fundamental voltage V_1 , it is required to determine the switching angles so that output voltage $V_o(wt)=V_1\sin(wt)$ and a specific higher harmonics of $V_n(nwt)$ are equal to zero. According to the three phase theory in balanced three phase system third order harmonic is cancelled.

One approach to solve the set of nonlinear transcendental equations (9) is to use an iterative method such as the Newton-Raphson method [9]. In contrast to iterative methods, the approach here is based on solving polynomial equations using the theory of resultants which produces all possible solutions [10]. The transcendental equations characterizing the harmonic content can be converted into polynomial equations. Then the resultant method is employed to find the solutions when they exist. These sets of solutions have to be examined for its corresponding total harmonic distortion (THD) in order to select the set which generate the lowest harmonic distortion.

V. SIMULATION RESULTS

In this paper, the simulation model is developed with MATLAB/Simulink. Figs. 5 & 6 show the closed loop configuration of eleven-level inverter. Filtered output voltage obtained from the eleven-level inverter through RC low pass filter. Output voltage feedback is given to the summer to compare the output voltage with reference voltage and the error voltage level obtained from the output of the summer for further operation. There are two inputs to the fuzzy logic controller one is error and derivative of the error, derivative of the error obtained from the previous sample value of the error voltage signal. The role of fuzzy logic controller is to convert the given crisp inputs to fuzzy sets using fuzzification, and then process the fuzzy sets as per the fuzzy rules and evaluation mechanism using fuzzy inference system. Output of the inference system is fuzzy sets, which is again converted to crisp output through defuzzification process. This modulator output compared with triangular wave to produce pulses to the switches of eleven-level inverter.

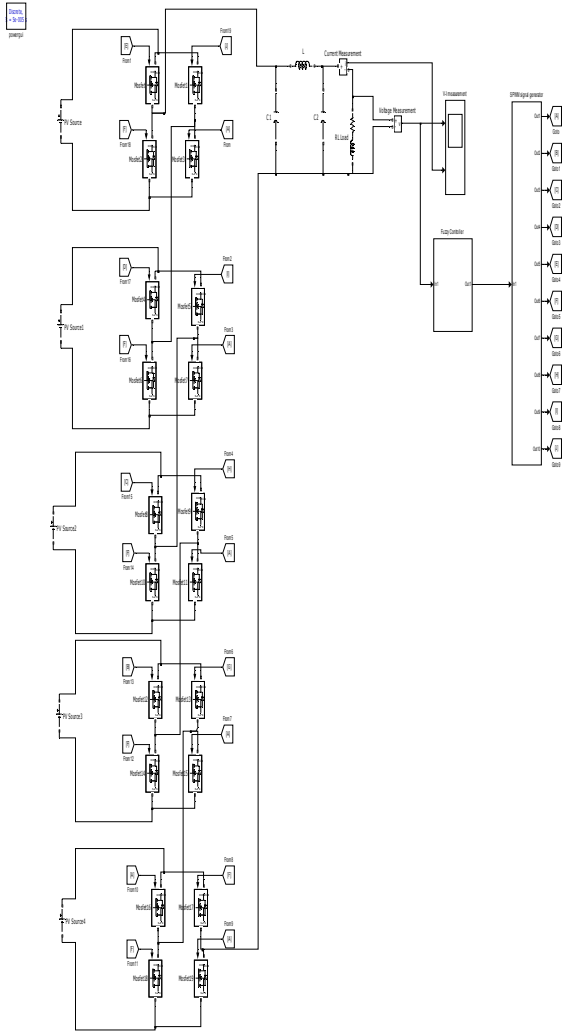

Fig. 5 Simulink model of eleven level inverter (closed loop)

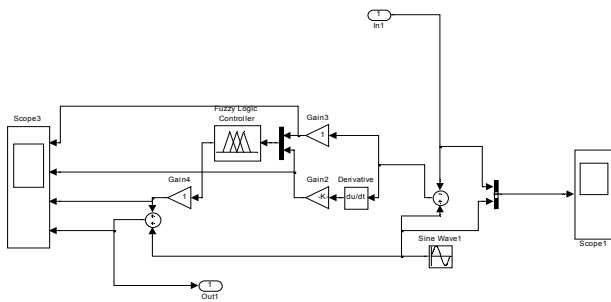

Fig. 6 Fuzzy circuit

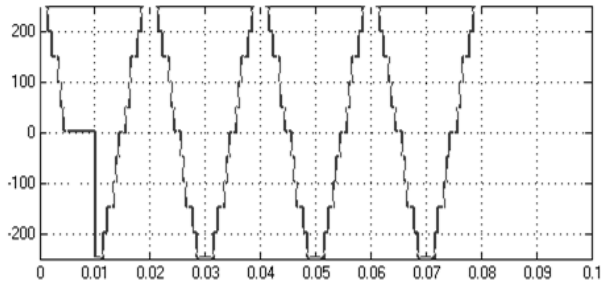

Fig. 7 Output voltage waveform of eleven-level Inverter without filter

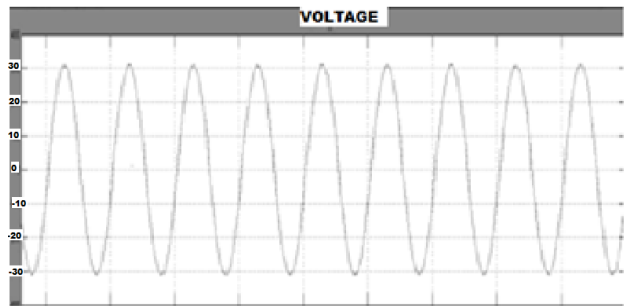

Fig. 8 Output voltage waveform of eleven-level Inverter with filter

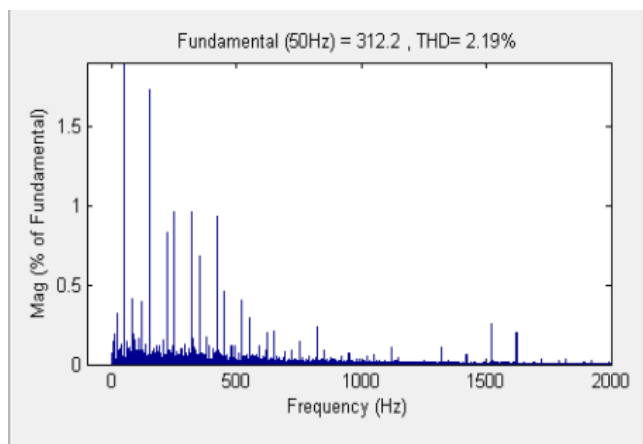

Fig. 9 FFT analysis for eleven level inverter

Figs. 7 and 8 show the eleven-level output voltage of the inverter before the filter and after the RC low pass filter. Based on the harmonic analysis, total harmonic distortion is less in the filtered output voltage of the eleven-level inverter. From the FFT analysis shown in Fig. 9, it is observed that the total harmonic distortion is 2.19%.

VI. CONCLUSION

In the present work, a Single Phase Cascaded H-Bridge Eleven-level Inverter with fuzzy logic controller using photovoltaic power source was simulated using MATLAB/SIMULINK and Sinusoidal pulse width modulation control technique was used to control this inverter. By tuning the Fuzzy logic controller required RMS Voltage with less harmonic distortion obtained in Closed Loop Configuration.

Hence we could achieve the improved efficiency of the system and better performance over cascaded h-bridge nine level inverter.

REFERENCES

- [1] Juan Manuel Carrasco, Leopoldo Garcia Franquelo, "Power-Electronic Systems for the Grid Integration of Renewable Energy Sources: A Survey", *IEEE Transactions on Power Electronics*, Vol.53, No.4, pp 1002-1016, Aug 2006.
- [2] Jeyraj Selvaraj and Nasrudin Rahim A, "Multilevel Inverter for Grid-Connected PV System Employing Digital PI Controller", *IEEE Transactions on Power Electronics*, Vol.56, No.1, pp 149-158, Jan 2009.
- [3] Bakhshai.A, Jain.P and, Khajehoddi, "The application of the cascaded multilevel converters in grid connected photovoltaic systems," In *Proc. IEEE Epc, Montreal, Qc, Canada*. July 2007.
- [4] M. Tolbert, F. Z. Peng, T. G. Habetler, 1999, "Multilevel converters for large electric drives," *IEEE Transactions on Industry Applications*, vol. 35, no. 1, pp. 36-44.
- [5] F. T. Josh, Jovitha Jerome, and J. Arulwilson, 2013, "Fuzzy Logic based nine level Inverter for photovoltaic systems", *European Journal of Scientific Research*, Vol.78, No.3, pp.522-533.
- [6] L. G. Franquelo, J. Rodriguez, J. I. Leon, S. Kouko, R. Portillo, and M. A. M. Prats, "The age of multilevel converters arrives," *IEEE Ind. Electron. Mag.*, vol. 2, no. 2, pp. 28-39, Jun. 2008.
- [7] S. B. Kjaer, J. K. Pedersen, and F. Blaabjerg, "A review of single phase grid-connected inverters for photovoltaic modules," *IEEE Trans. Ind. Appl.*, vol. 41, no. 5, pp. 1292-1306, Sep./Oct. 2005.
- [8] F. S. Kang, S. J. Park, S. E. Cho, C. U. Kim, and T. Ise, "Multilevel PWM inverters suitable for the use of stand-alone photovoltaic power grid-connected inverters for photovoltaic modules," *IEEE Trans. Energy Convers.*, vol. 20, no. 4, pp. 906-915, Dec. 2005.
- [9] Jose Rodriguez, Jin-Sheng Lai and Fang Zheng, 2002, "Multi level Inverters: A survey of topologies, Control applications," *IEEE transactions on Industrial Electronics*, Vol.49, No. 4, pp. 724-738.
- [10] Carlo Cecati, Fabrizio Ciancetta, Pierluigi Siano, "A Multilevel Inverter for Photovoltaic Systems with Fuzzy Logic Control", *IEEE Trans. Ind. Electron.*, vol. 57, no. 12, pp. 4115-4125, Dec. 2010.

M.S.Sivagamasundari (born May 14, 1977) took her B.E in Electrical and Electronics Engineering from the C.S.I Institute of Technology, Thovalai, M.E in Power Electronics & Industrial Drives from the Sathyabama University, in 1999 and 2010 respectively. Currently she is pursuing P.hd in Anna University. She is a member in various professional bodies like ISTE, ISOL, IE(I) and SESI. She has more than eight years of teaching experience and one year of industrial experience. She has presented papers in various conferences and published 1 paper in national and 19 papers in International journals. Currently, she is working as an Asst.professor in Electrical and Electronics department in VV College of Engineering, Tisaiyanvilai. Her research interests include power electronics and renewable energy sources.

Prof. Dr. P. Melba Mary (born October 7, 1969) took her B.E in Electrical and Electronics from the Government College of Engineering, Tirunelveli, M.E in Control and Instrumentation from the College of Engineering, Guindy, Anna University, Chennai in 1990 and 1995 respectively. She worked as lecturer in National Engineering College, Kovilpatti and as Professor and Head of the Electrical and Engineering department at National College of Engineering, Maruthakulam. She has a few years of industrial experience too. Her main research interests on hybrid control system theory, industrial process control, robotics and various intelligent techniques used in the design of controllers. She has presented papers in various conferences and published many papers in National and International journals. She is a member in various professional bodies like ISTE, IEEE, IET,IE(I) and a Fellow of the Institution of Electronics and Telecommunication Engineers (IETE). Currently, she is working as Principal in VV College of Engineering, Tisaiyanvilai.