

Simulation of Static Frequency Converter for Synchronous Machine Operation and Investigation of Shaft Voltage

Arun Kumar Datta, M. A. Ansari, N. R. Mondal, B. V. Raghavaiah, Manisha Dubey, Shailendra Jain

Abstract—This study is carried out to understand the effects of Static frequency converter (SFC) on large machine. SFC has a feature of four quadrant operations. By virtue of this it can be implemented to run a synchronous machine either as a motor or alternator. This dual mode operation helps a single machine to start & run as a motor and then it can be converted as an alternator whenever required. One such dual purpose machine is taken here for study. This machine is installed at a laboratory carrying out short circuit test on high power electrical equipment. SFC connected with this machine is broadly described in this paper. The same SFC has been modeled with the MATLAB/Simulink software. The data applied on this virtual model are the actual parameters from SFC and synchronous machine. After running the model, simulated machine voltage and current waveforms are validated with the real measurements. Processing of these waveforms is done through Fast Fourier Transformation (FFT) which reveals that the waveforms are not sinusoidal rather they contain number of harmonics. These harmonics are the major cause of generating shaft voltage. It is known that bearings of electrical machine are vulnerable to current flow through it due to shaft voltage. A general discussion on causes of shaft voltage in perspective with this machine is presented in this paper.

Keywords—Alternators, AC-DC power conversion, capacitive coupling, electric discharge machining, frequency converter, Fourier transforms, inductive coupling, simulation, Shaft voltage, synchronous machines, static excitation, thyristor.

I. INTRODUCTION

THERE are various means of starting a synchronous machine from standstill. The old conventional methods (with additional motor) are less energy efficient and also need a huge investment and time. After the invention of high rating semiconductor devices, static starting devices are designed to start and run a large synchronous motor. One of these static starting devices is known as Static Frequency Converter (SFC).

Though the concept of frequency converter is very old, but its application has increased in the recent years in the field of aviation industry, computer installations, communications, military installations, motor speed control, ships and power transmission. Frequency converter converts supply frequency to load requirement frequency. It has a feature of four quadrant operations. High power thyristor based SFC is in use

Arun Kumar Datta, M. A. Ansari, N. R. Mondal, and B. V. Raghavaiah are with Central Power Research Institute, Bhopal, India (Phone: +919425371370; e-mail: akdbpl@gmail.com).

Manisha Dubey and Shailendra Jain are with Maulana Azad National Institute of Technology, Bhopal, India.

worldwide for starting and speed control of AC motors by providing a power supply of variable frequency and voltage simultaneously. It is normally used in gas turbine based power plant, pump storage power plant, railways and large synchronous motor [1]-[4]. SFC technology has also been extended to the field of short circuit alternator [5], [6]. This alternator runs as a synchronous motor and later on converted to generator by virtue of SFC. As a generator it supplies energy to the electrical power equipment during tests. No additional prime mover is required to start and run this machine. Only rotor field power is required which is supplied through a static excitation system (SES) [7]. SES has already been implemented in power generator since beginning of sixties [8], [9]. It is basically a poly-pulse AC-DC power conversion [10] system with different control circuitry. Pictorial view of the short circuit alternator and its single line diagram is shown in Fig. 1.

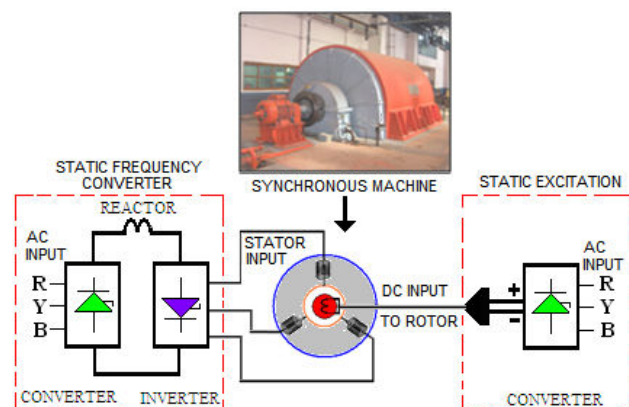

Fig. 1 Short circuit alternator with connected systems

SFC has an edge over the various methods of starting in terms of operation flexibility, quick response, easy monitoring, control and troubleshooting. Being the static source it has only one concern i.e. of shaft voltage. Shaft voltage is a very common phenomenon in large machine [11]-[13].

Bearing current is the ultimate result of shaft voltage. Many papers have been published on the effect shaft voltage on induction motors [14]-[18]. Different solution techniques to eliminate shaft voltage are common mode voltage reduction, inverters topologies and filter circuits (active, passive or

hybrid) [19]-[26]. This field is still under the scope of research.

Effect of static power supplies on large synchronous machine has broadly discussed in paper nos. [27] & [28]. This paper begins with the details of SFC circuitries and its functions. Thereafter a MATLAB/Simulink model [29] of SFC is prepared with circuit parameters. The model is run and the waveforms are viewed in scope and plot windows. These results are validated with the waveforms recorded from the actual bridge with a high speed recorder. All the waveforms are process through FFT analysis tool. Fourier transformation shows the presence of number of harmonics in the waveforms. A discussion on the shaft voltage is brought out on the basis of these results.

II. SFC: CONFIGURATION

SFC is a combination of two 6-pulse thyristor bridges (Fig. 2) with an intermediate dc link reactor [30]. The first bridge named as network bridge (NB) connected with a source transformer. Second bridge is called machine bridge (MB) that connects the machine stator terminals. Both these bridges can be operated either as rectifier or inverter depending upon the machine requirements as motor or generator. In normal mode NB acts as rectifier and power frequency supply is converted to DC. This DC contains ripples which are filtered by the link reactor. MB operates as an inverter producing three-phase alternating current, the frequency of which is varied from a very low value up to the nominal value. Thyristor firing angle in the NB & MB are set by a controller [31], [32] with various feedback loops.

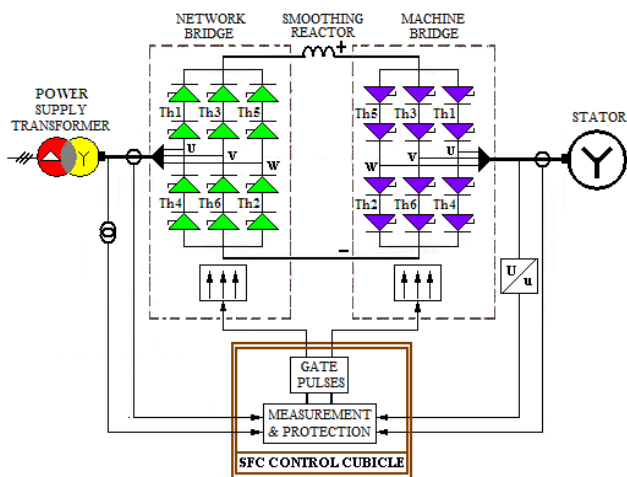

Fig. 2 SFC configuration

SFC panel is divided in two main parts (Fig. 3). One is power cubicle, consisting of thyristors and snubber circuits. The second part is the CPU with other electronic control circuitry and feedback circuits. It is named as power electronic controller (PEC) and acts very fast in a μ sec range during short circuit test sequence [33]. A human machine interface

(HMI) fitted on the controller visualises all fault and abnormality records in the SFC.

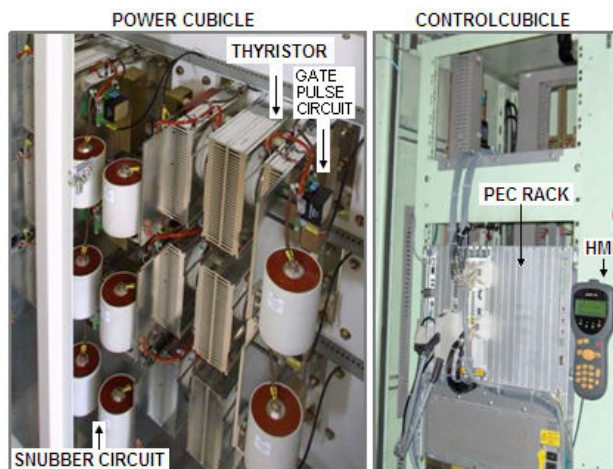

Fig. 3 Static frequency converter for 1500MVA short circuit alternator

III. MOTOR OPERATION WITH SFC

SFC feeds variable frequency supply to the machine through a cable. It starts the machine as a motor from standstill to the rated rpm value (Fig. 4). The acceleration is kept low to maintain the synchronism at all speed. Another benefit of low acceleration is less loading on the source.

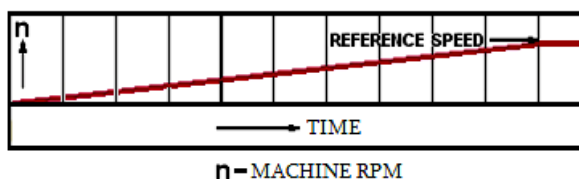

Fig. 4 Synchronous motor speed

At rated speed motor voltage and current are measured with a high speed waveform recorder. For voltage measurement Hall effect transducer is connected across the motor terminals. Current is measured by a specially designed variable frequency CT through which motor cable is passed. Motor voltage & current waveforms are displayed in Figs. 5 & 6. As the waveforms are not purely sinusoidal their fast Fourier transformation are carried out to view the harmonics content. FFT analysis of motor voltage and current are shown in Figs. 7 & 8.

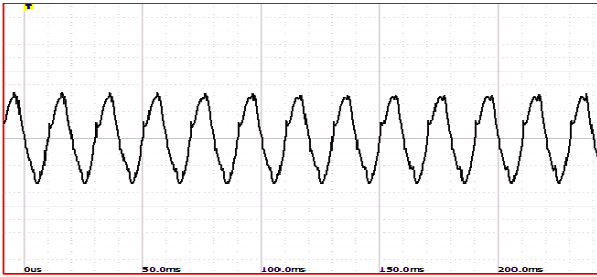

Fig. 5 Synchronous motor phase voltage



Fig. 8 FFT of MB current

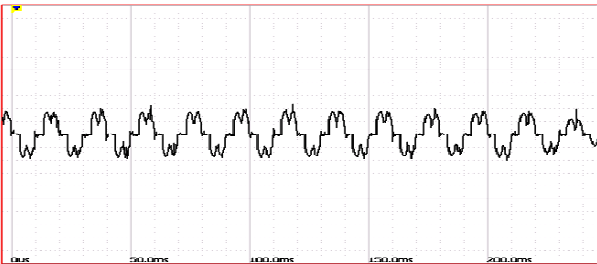

Fig. 6 Synchronous motor line current

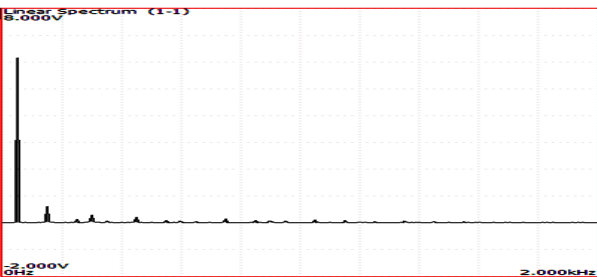

Fig. 7 FFT of motor voltage

IV. SFC: SIMULINK MODEL

Modelling of SFC is done to understand its intricacies in a simple manner. Simulink platform of MATLAB is used to model the SFC system (Fig. 9).

One source transformer, two thyristor converter bridges, pulse generators and control circuitries are taken to create the model. Following parameters are taken from the actual SFC configuration working for the short circuit alternator:

TABLE I
SFC MODEL PARAMETER VALUES

Parameter	Value
Input source	33kV, three phase
Transformer nominal power	3.5 MVA
Transformer primary input, Delta winding	33kV, 50Hz
Transformer secondary output, Star winding	1.72kV
Thyristor bridge	3 arms
Snubber resistance	2000 Ω
Snubber capacitance	0.1 μF
Link reactor	4.8mH
Base voltage	12kV
X/R ratio	7
Motor voltage	1.72kV
Motor RPM	3000

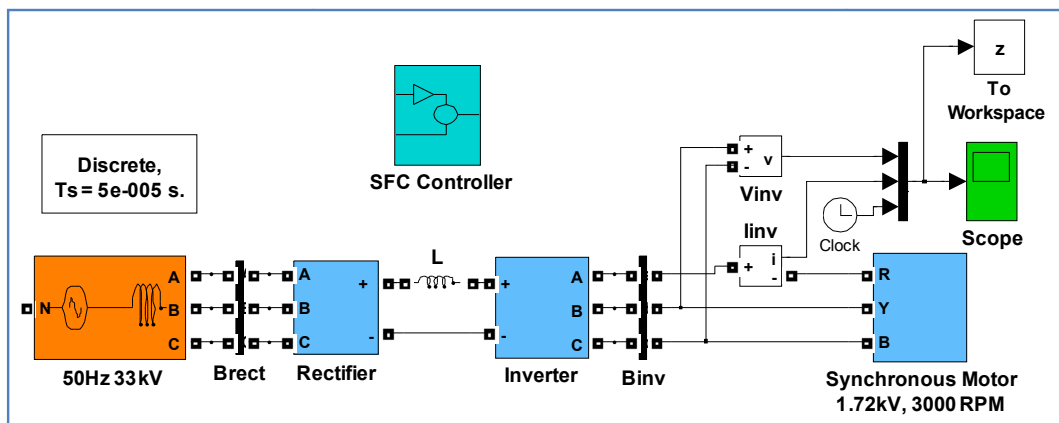

Fig. 9 Simulink model of SFC

V. SIMULATION RESULTS

The simulated model is run and waveforms are viewed on the scope window (Fig. 10). For better representation of motor voltage and current they are plotted again with the help of

MATLAB Script file (Figs. 11 & 12). Further the FFT analysis is done on these waveforms to find out the level of harmonics (Figs. 13 & 14).

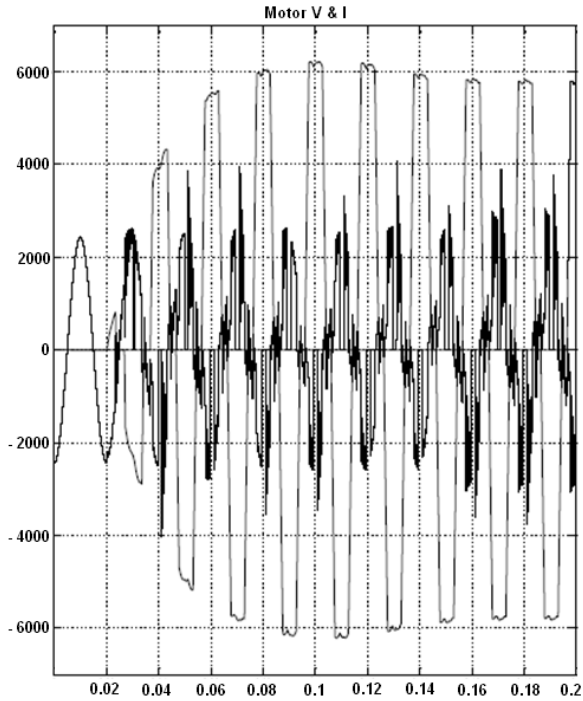

Fig. 10 Scope view of simulated motor voltage and current

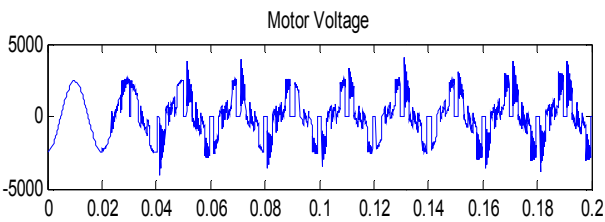

Fig. 11 Simulated motor voltage in plot window

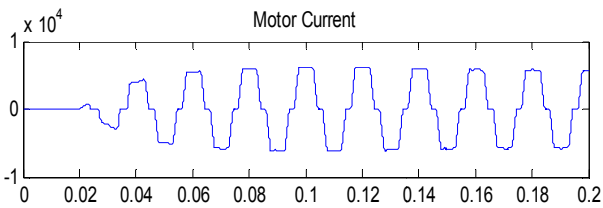

Fig. 12 Simulated motor current in plot window

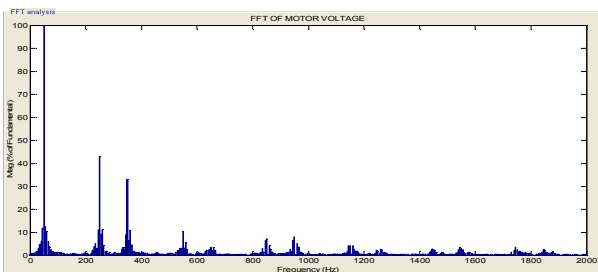

Fig. 13 FFT for simulated motor voltage

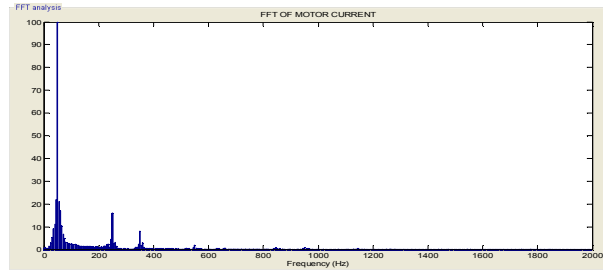

Fig. 14 FFT for simulated motor current

VI. DISCUSSION

The simulated traces and actual waveforms of motor voltage and current are compared and found similar in nature. FFT analyses of simulated and actual waveforms are also matching. Strong presence of harmonics and switching surges are confirmed by FFT. Capacitive and inductive couplings in the complete alternator system are the results of harmonics and other high frequency signals. Winding insulation, air and lubricating oil work as dielectric medium for forming the distributed capacitance in the machine. This capacitance (also called parasitic capacitance) form between stator to ground, stator to rotor, stator to shaft, rotor to shaft, bearing to ground, cable to ground and also supply source to ground. Parasitic capacitance is responsible for flow of leakage current all along the stator and rotor windings which generates high frequency flux. Flux is also generated due to harmonics and switching surges. All these fluxes link with winding, core, frame, shaft, and other metallic parts and form inductive coupling. Capacitive and inductive couplings together give an additive effect for shaft voltage generation in a machine.

Shaft voltage creates electrostatic discharges to the ground in the form of small duration high current pulses and contain huge amount of energy (Fig. 15). This energy is the prime cause of bearing erosion which is commonly known as fluting or electric discharge machining (EDM).



Fig. 15 Electrostatic discharges from the machine shaft

VII. CONCLUSION

SFC is the first choice of the designers for starting and speed control of large machines. It doesn't need additional rotating device to start and run a synchronous machine. Machine can be started softly without much loading the supply source. Other than starting, SFC can also be used for braking and reversal operation of the machine. By virtue of MATLAB/Simulink software, SFC is modeled from the actual parameters. Simulation results are validated with the waveforms drawn from the real bridge in SFC.

Like other static sources the SFC has also one negative aspect i.e. generation of shaft voltage. Reasons behind this unwanted voltage are capacitive and inductive coupling. High level of harmonics in motor voltage & current waveforms cause capacitive and inductive couplings. FFT analyses on simulated and actual measurements show that the waveforms contain high percentage of harmonics.

Flow of current due to the presence of shaft voltage can damage bearing, shaft and other nearby metal parts of any machine. Large machine requires sufficient time and money to repair the damaged part. Hence to increase the machine life shaft voltage needs to be properly minimized. Though this study is carried out on a specially designed alternator used for short circuit testing, but the findings are useful to other large machines connected with static drives.

ACKNOWLEDGMENT

Authors are thankful to the management of Central Power Research Institute, India for supporting this work.

REFERENCES

- [1] A. Hisanori Taguchi, et al., "APS Control Method for Gas Turbine Startup by SFC", International Power Electronics Conference, pp.264-269 IEEE, 2010.
- [2] Shin-Hyun Park, Seon-Hwan Hwang, Jang-Mok Kim, Ho-Seon Ryu, Joo-Hyun Lee, "A Starting-up control algorithm of large synchronous generation motor for Gas Turbosets", *IEEE International Symposium on Industrial Electronics ISIE*, pp.502-508, 2008.
- [3] Zhang Yu-Zhi, "Study of Process of Starting Pumped Storage Machines by Static Frequency Converter with Field Current Controlled", International Conference on Signal Processing Systems, pp. V1-224 – V1-227, IEEE2010.
- [4] Robert B., Fisher, P.E., "Introduction of Static Frequency Converters on SEPTA's 25Hz Commuter Rail System", pp.149-155, IEEE.
- [5] Datta A. K., Manisha Dubey, N. R. Mondal, B. V. Raghavaiah, "Motor-less operation of Short Circuit generator – A CPRI Perspective", *International Conference on Electrical Power and Energy Systems (ICEPES-2010)*, pp.439-445, 26-28 August 2010 MANIT, Bhopal.
- [6] Datta Arun Kumar, Ansari M. A., Mondal N. R., Raghavaiah B. V. "A Novel Use of Power Electronics: Prime Mover-less Alternator with Static Drive & Excitation System" *International Journal of Electronics & Communication Technology*, Vol. 3, Issue 1, pp. 472-475, January - March 2012.
- [7] Arun Kumar Datta, G. Venkateswarlu, J. R. Gajbhiye, "Excitation Control in Motor Mode of Short Circuit Generator", *All India Conference on Environmental Impact of Electrical & Electronics Engineering (AICON'12)*, pp.31-34, 20-21 Jan 2012, CSIT, Durg.
- [8] L. J. Lane, D. F. Rogers, P. A. Vance, "Design and Tests of a Static Excitation System for Industrial and Utility Steam Turbine-Generators", pp.1077-1085, A.I.E.E., 1962.
- [9] R.C. Schaefer, "Applying Static Excitation Systems", pp. 41-49, IEEE Industry Application Magazine Nov/Dec1998.
- [10] Tsong-Juu Liang, et al, "Analysis of 12 Pulse Phase Control AC/DC Converter", IEEE 1999 International Conference on Power Electronics and Drive Systems, PEDS'99, pp.779-783, July 1999, Hong Kong.
- [11] Datta Arun Kumar, Dubey Manisha, Jain Shailendra, "Study of shaft voltage & bearing currents in electrical machines," *IEEE Students' Conference on Electrical, Electronics and Computer Science (SCEECS)*, pp.1-4, 1-2 March 2012.
- [12] C. Ammann, K. Reichert, R. Joho Z. Posedel, Shaft Voltages in Generators with Static Excitation Systems - Problems and Solution, *IEEE Transactions on Energy Conversion*, pp.409-419, Vol. 3, No. 2, June 1988.
- [13] Sidney Bell, Timothy J. Cookson, Steven A. Cope, Richard A. Epperly, Annika Fischer, David W. Schlegel, and Gary L. Skibinski, "Experience with variable-frequency drives and motor bearing reliability", *IEEE Transactions on Industry Applications*, vol. 37, no. 5, pp.1438-1446, September/October 2001.
- [14] S. Chen, T. A. Lipo, and D. Fitzgerald, "Measurement and analysis of induction motor bearing currents in pwm inverter drives", Research report 95-20, June 1995, IEEE Summer Power Meeting, July 1995.
- [15] J. Erdman, R. J. Kerkman, D. Schlegel, and G. Skibinski, "Effect of PWM inverters on AC motor bearing currents and shaft voltages," *IEEE Transaction on Industrial Application*, vol. 32, pp. 250-259, Mar./Apr. 1996.
- [16] Shaotang Chen, T. A. Lipo, "Circulating Type Motor Bearing current in Inverter Drives", - IEEE Industry Applications Magazine, pp. 32-38, January/February 1998.
- [17] Muetze A. and Binder A., "Calculation of circulating bearing currents in machines of inverter-based drive systems", *IEEE Transactions on Industrial Electronics*, vol. 54, no. 2, pp. 932-938, April 2007.
- [18] Muetze A., "On a new type of inverter-induced bearing current in large drives with one journal bearing" *IEEE Transactions on Industry Applications*, vol. 46, no. 1, pp.240-248, January/February 2010.
- [19] Fei Wang, "Motor shaft voltages and bearing currents and their reduction in multilevel medium-voltage PWM voltage-source-inverter drive applications", *IEEE Transactions on Industry Applications*, vol. 36, no. 5, pp.1336-1341, September/October 2000.
- [20] M. R. Baiju, K. K. Mohapatra, R. S. Kanchan, and K. Gopakumar, "A dual two-level inverter scheme with common mode voltage elimination for an induction motor drive", *IEEE Transactions on Power Electronics*, vol. 19, no. 3, pp. 794-805, May 2004.
- [21] Hirofumi Akagi and Takafumi Doumoto, "An approach to eliminating high-frequency shaft voltage and ground leakage current from an inverter-driven motor" *IEEE Transactions on Industry Applications*, vol. 40, no. 4, pp. 1162-1169, July/August 2004.
- [22] R. S. Kanchan, P. N. Tekwani, and K. Gopakumar, "three-level inverter scheme with common mode voltage elimination and DC link capacitor voltage balancing for an open-end winding induction motor drive," *IEEE Transactions on Power Electronics*, vol. 21, pp. 1676-1683, 2006.
- [23] Akagi, H.; Isozaki, K.; "A hybrid active filter for a three-phase 12-pulse diode rectifier used as the front end of a medium-voltage motor drive", *IEEE Transactions on Power Electronics*, vol.27, no.1, pp.69-77, Jan. 2012.
- [24] Zhao, Z.; Zhong, Y.; Gao, H.; Yuan, L.; Lu, T.; , "Hybrid selective harmonic elimination PWM for common-mode voltage reduction in three-level neutral-point-clamped inverters for variable speed induction drives," *IEEE Transactions on Power Electronics*, vol.27, no.3, pp.1152-1158, March 2012.
- [25] Yuen, K. K.-F.; Chung, H. S.-H.; Cheung, V. S.-P.; , "An active low-loss motor terminal filter for overvoltage suppression and common-mode current reduction" *IEEE Transactions on Power Electronics*, vol.27, no.7, pp.3158-3172, July 2012.
- [26] Zhu, N.; Xu, D.; Wu, B.; Zargari, N. R.; Kazerani, M.; Liu, F.; , "Common mode voltage reduction methods for current-source converters in medium-voltage drives," *IEEE Transactions on Power Electronics*, vol.28, no.2, pp.995-1006, Feb. 2013.
- [27] Arun Kumar Datta, Manisha Dubey, Shailendra Jain, "Study of Shaft Voltage on Short Circuit Alternator with Static Frequency Converter", *International Journal of Electrical, Electronic Science and Engineering, World Academy of Science, Engineering and Technology (WASET)* pp. 692-698, Vol.7 No.11, 2013.
- [28] Datta Arun Kumar, Dubey Manisha, Jain Shailendra, "Investigation of bearing currents in dual mode operation of synchronous machine with static excitation system," pp. 45-53, *Electrical and Electronics Engineering: An International Journal (ELELIJ)* Vol 2, No 4, November 2013.

- [29] The MathWorks™, Inc., USA, Release 2008a (R2008a).
- [30] Tore Peterson, Kjell Frank, "Starting of large synchronous motor using static frequency converter", paper 71 TP 519-PWR for IEEE International Symposium on High Power Testing, Portland, Ore., pp.172-179, July 18-23, 1971.
- [31] Tian Hua Liu, et al., "Modeling and Harmonic Elimination for a Static Frequency Converter Driving a 300 MVA Synchronous Machine", pp.602-607, IEEE, 1996.
- [32] Ho-Seon Ryu, et al "A Study of Synchronous Motor Drive using Static Frequency Converter" EPE-PEMC, pp.1496-1499, 2006, IEEE.
- [33] Datta A. K., G. Venkateswarlu, M. A. Ansari, N. R. Mondal, "Excitation Control during Short Circuit Test Sequence of 1500 MVA Short Circuit Generator", *International Conference on Advances in Computer, Electronics & Electrical Engineering (ICACEE-2012)*, pp.207-211, 25-27 March 2012 Mumbai.



Arun Kumar Datta graduated in Electrical Engineering in 1990 from Govt. Engineering College, Bilaspur in India. In 1992 he did his post graduation (M.Tech.) from MACT (REC), Bhopal, India. In March 1993 he joined Central Power Research Institute (CPRI) India and looking after the Operation & Maintenance of two 1500MVA short circuit generator plant and a medium voltage substation at Bhopal unit. He is also the Deputy Quality Assurance Co-ordinator of CPRI Bhopal unit. He had undergone training at many places including the works of M/s. Alstom, France. He is a Certified Energy Auditor from Bureau of Energy Efficiency (BEE) and also a member of Institution of Engineers (India). He has attended many International & National Conferences and has many papers on his credential. Other than his regular assignments he is also pursuing Ph.D. from Maulana Azad National Institute of Technology (MANIT), Bhopal, India.



M. A. Ansari obtained BE Electrical Engineering from Govt. Engg. College Bilaspur in 1984. He joined CPRI in Oct 1984. Worked for 10 years in 100MVA Online Testing Station and carried out testing of various LT equipments & transformers as per IS/IEC. Since 1995 working in 1500 MVA short circuit testing station as Operation and Maintenance Engineer. He is also Quality Assurance Co-ordinator of CPRI STDS Bhopal laboratories.



N.R. Mondal graduated in Electrical Engineering from Maulana Azad College of Technology, Bhopal in 1982. He obtained M.Tech degree from MACT Bhopal in 1992. From 1982 to 1984 he worked for NHPC in the field of commissioning of projects. In 1984 he joined CPRI. Initially worked as test engineer in 1500MVA short circuit testing station and carried out testing on various HT/LT equipments as per national & international standards. Presently working as Joint Director of O&M division and looking after overall Operation and Maintenance of 1500 MVA short circuit plant. Undergone training at the works of M/s Alstom, France. He visited Austria to inspect the Current Limiting Reactors using for short circuit testing. He carried out third party inspection of large power transformers at the works of leading transformer manufacturer at abroad. He is having rich experience around 28 years in Operation & Maintenance of various equipments used in short circuit plant. He has presented several technical papers in National and International levels.



B. V. Raghavaiah has post graduated in 1981 with specialization in Power Systems & High Voltage Engineering from JNTU, Hyderabad, joined Central Power Research Institute, Bhopal as Scientist in 1981. He is associated with testing and certification of all LT/HT electrical and other allied transmission and distribution equipments and implemented various developmental projects, R&D works, consultancy works and also involved in third party inspections in India and abroad. He has presented several technical papers in National and International levels. Presently he is holding the position of Additional Director and Unit Head of CPRI, Bhopal. He is a member of BIS, CIGRE, and many other regulatory bodies and organisations constituted by GOI. He visited ABB Switzerland, CESI Italy test laboratories, represented CPRI at Malaysia for preparation and

finalisation of transformer specifications for Global bids for TNB, Malaysia. He has also visited Japan to witness the tests as international inspector of Short Circuit testing Liaison (STL).



Manisha Dubey was born in Jabalpur in India on 15th December 1968. She received her B.E (Electrical), M.Tech. (Power Systems) and Ph.D (Electrical Engg.) in 1990, 1997 and 2006 respectively. She is working as Professor at the Department of Electrical Engineering, National Institute of Technology, Bhopal, India. Her research interests include power systems, Genetic Algorithms, Fuzzy Logic systems and application of Soft Computing Techniques in power system dynamics and control. She is the member of IEEE, IE & ISTE, etc.



Shailendra Jain received the B.E. degree in electrical engineering from Samrat Ashok Technological Institute Vidisha, India in 1990, the M.E. degree in power electronics from Shri Govindram Seksaria Institute of Technology and Science, Indore, India, in 1994, the Ph.D. degree from the Indian Institute of Technology, Roorkee, India, in 2003, and the PDF from the University of Western Ontario, London, ON, Canada, in 2007. He is a Professor in the Department of Electrical Engineering, National Institute of Technology, Bhopal, India. His research interests include power electronics and electric drives, power quality improvement, active power filters, high-power-factor converters, and fuel-cell-based distributed generation. Dr. Jain was a recipient of the "Career Award for Young Teachers" from the All India Council for Technical Education (AICTE), New Delhi, India, for the year 2003-2004.