

# Conceptual Design of Experimental Helium Cooling Loop for Indian TBM R&D Experiments

B. K. Yadav, A. Gandhi, A. K. Verma, T. S. Rao, A. Saraswat, E. R. Kumar, M. Sarkar, K. N. Vyas

**Abstract**—This paper deals with the conceptual design of Experimental Helium Cooling Loop (EHCL) for Indian Test Blanket Module (TBM) and its related thermal hydraulic experiments. Indian TBM team is developing Lead Lithium cooled Ceramic Breeder (IN-LLCB) TBM to be tested in ITER. The TBM box structure is cooled by high pressure (8 MPa) and high temperature (300-500C) helium gas.

The first wall of TBM made of complex channel geometry having several parallel channels carrying helium gas for efficient heat extraction. Several mock-ups of these channels need to be tested before finalizing the TBM first wall design and fabrication. Besides the individual testing of such mock-ups of breeding blanket, the testing of Pb-Li to helium heat exchanger, the operational experience of helium loop and understanding of the behavior of high pressure and high temperature system components are very essential for final development of Helium Cooling System for LLCB TBM in ITER. The main requirements and characteristics of the EHCL and its conceptual design are presented in this paper.

**Keywords**—DEMO, EHCL, ITER, LLCB TBM.

## I. INTRODUCTION

ONE of the key missions of the International Thermonuclear Experimental Reactor (ITER) is to validate the design concepts of tritium breeding blankets relevant to a power-producing reactor like DEMO. ITER should demonstrate the feasibility of the breeding blanket concepts that would lead to tritium self-sufficiency and the extraction of a high-grade heat, which are necessary goals for the DEMO [3]-[6].

India is working on a Lead Lithium cooled Ceramic Breeder (LLCB) blanket as one of the options for a DEMO relevant blanket concept. Indian Lead Lithium cooled Ceramic Breeder (IN LLCB) Test Blanket Module (TBM) is planned to be tested in equatorial port no#2 in ITER [3]. The LLCB blanket concept consists of lithium titanate as ceramic breeder material in the form of packed pebble beds. The structural material is ferritic steel and is cooled by helium gas. In LLCB, the Pb-Li eutectic acts as multiplier, breeder and coolant. The Pb-Li flow velocity is moderate enough such that the heat generated within and the heat transferred from ceramic breeder zone is extracted effectively. Helium gas is used as a primary coolant for plasma facing TBM first wall [1]. The first wall of TBM consists of several parallel channels of complex

Brijesh Kumar Yadav, Ankit Gandhi, Aditya Kumar Verma, T. Srinivas Rao, Abhishek Saraswat, and E. Rajendra Kumar are with Institute for Plasma Research, near Indira Bridge, Bhat, Gandhinagar-382428. India (e-mail: byadav@ipr.res.in).

Mausam Sarkar and K. N. Vyas are with Bhabha Atomic Research Center, Trombay, Mumbai- 400 085, India (e-mail: z7410701@iitb.ac.in).

geometry carrying helium gas for efficient heat extraction. Several mock-ups of these channels need to be tested to validate the design and finalizing the TBM first wall design and fabrication [4].

Outside the TBM, the Pb-Li eutectic is cooled by another helium system called Lead Lithium Helium Cooling System (LLHCS). Lead-lithium to helium heat exchanger is the interfacing equipment between the two coolant circuits' i.e. Pb-Li system & LLHCS [2]. Besides the individual testing of such mock-ups of breeding blanket, integrated operation of the loop, and understanding of the behavior of high pressure and high temperature system components are very essential for final development of Helium Cooling System for LLCB TBM in ITER [5].

The main requirements and characteristics of the EHCL facility and a conceptual design are described in the paper. Finally, the equipments investigation and information about instrumentation and control system has been presented to fulfill EHCL thermal-hydraulics campaigns.

## II. EHCL PROCESS PARAMETERS

In this loop, model test section is simulated as First wall of LLCB TBM with maximum heat generation scaled down to 1/4<sup>th</sup> of the heat generation in the prototype. The loop is designed to operate with helium at 8MPa pressure, 400 C temperatures and 0.4 kg/s flow rate. However, the flow rate and temperature across Test Section Module (TSM) can be varied from 0.1 kg/s to 0.4 kg/s and from 100 C to 400 C respectively. In cold stand-by condition, the loop pressure is reduced to 0.1 MPa at RT. The variations in flow rate and temperature equip this facility to have number of TSMs, and it gives advantages to potential users of having different type of test mock-ups. In the first phase of experiments, the mock-up tests of FW are planned, and in successive campaigns, it is proposed to test and validate the design of liquid metal-to-helium heat exchanger. Table I gives the requirements for TBM FW mock-up experiments.

TABLE I  
REQUIREMENTS FOR TBM FW MOCK UP EXPERIMENTS

Parameters	Operating	Design
Heat load for TBM FW mock-ups, kW	18 - 75	75
Temperature at TSM, C	100-400	450
Coolant pressure (Helium), MPa	8.0	10.0
Coolant flow rate (Helium), kg/s	0.4, 0.3, 0.2, 0.1	0.4

## III. EHCL DESIGN FEATURES

The piping and instrumentation diagram of the loop is

presented in Fig. 1. The main equipments shown in the diagram are a TSM (simulated test section for TBM FW), a recuperator, circulators, a dust filter and helium water heat exchangers. Just before the TSM an electric heater is placed, this is used during warming up of the loop and to maintain the

TSM inlet temperature as per experimental requirements. Introduction of recuperator in the loop reduces thermal stresses on the helium-water heat exchanger. Maintaining low temperature helium to the suction of the helium circulator reduces compressor power requirement.

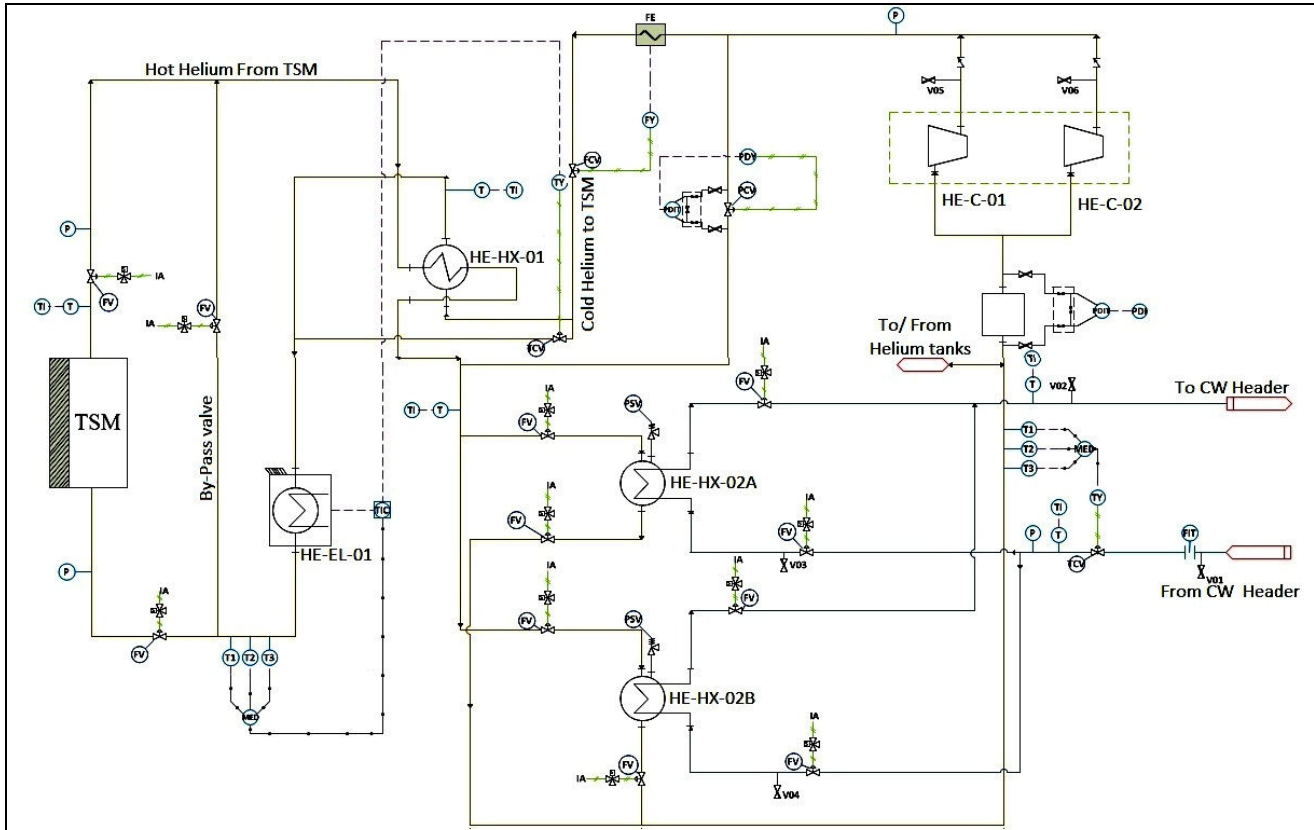

Fig. 1 P& ID of the main loop of EHCL

Also, in case of ITER LLCB helium system, this scheme is advantageous for reducing the tritium permeation in the helium water heat exchanger because of low average temperature of helium.

In the loop, two parallel circulators each of 0.2 kg/s mass flow rate are assembled. Based on the flow rate requirements one or both circulator shall be operated. The water flow rate required to extract heat from hot helium in the helium-water heat exchanger is modulated to maintain the helium coolant temperature of  $\leq 60$  C at circulator suction. Further, presence of bypass line across the circulator and by providing variable frequency drive for the circulator the required flow rate across TSM for a campaign can be achieved. In loop operation, the line connecting the circulator outlet to recuperator is relatively a cold line having temperature below 100 C. The line between electrical heater outlets to recuperator through TSM is hot line having maximum temperature 400 C. Temperatures of other lines are in between above-mentioned temperature values. The water line temperatures for heat exchangers are maintained from 25 C to 75 C.

Pressure and Inventory in the loop, is maintained by

Pressure and Inventory Control System (PICS). A single point connection at the suction of the main circulator, upstream to the inline dust filter is provided for the system to respond in any fluctuations of the system pressure by addition and withdrawal of the inventory as and when required by the main coolant loop. The pressure fluctuations in the main loop are expected to be in the range of  $\pm 5\%$  from the operating pressure of 8MPa.

The pressure control system operates with combination of tanks identified as storage, source, and buffer. The pressure control system is designed to store the entire inventory required in a campaign. Provisions are made for initial charging directly or via a compressor of the loop. The buffer tank acts as recipient of all discharges and maintained at lower pressure, source tank supplies inventory to main loop and is maintained at high pressure. Storage tank pressure is in between these pressure values during the regular operations of the PICS.

Pressure regulators are provided in the upstream and the downstream of the loop for regulating maximum and minimum pressure respectively while operating the main loop.

Pressure relief devices are provided for reducing excess pressure that might build up due to sudden power surge or temperature increase. Loop pressure surge invokes opening the relief valve if upstream pressure regulator capacity is not sufficient to relieve the pressure. Source tank and storage tank relief devices are provided to protect the equipment. Discharges from all relief valves are collected in buffer tank initially to retain the inventory within the system itself. In case

the buffer tank pressure increases beyond design value inventory is relieved to containment through relief valve.

Prior to the integration of circulator in the assembly, the circulator shall be tested for its performance in a separate circulator test loop. The circuit diagram for the circulator testing is presented in Fig. 2. In this loop, the performance characteristics and parameters of the circulator will be verified and measured.

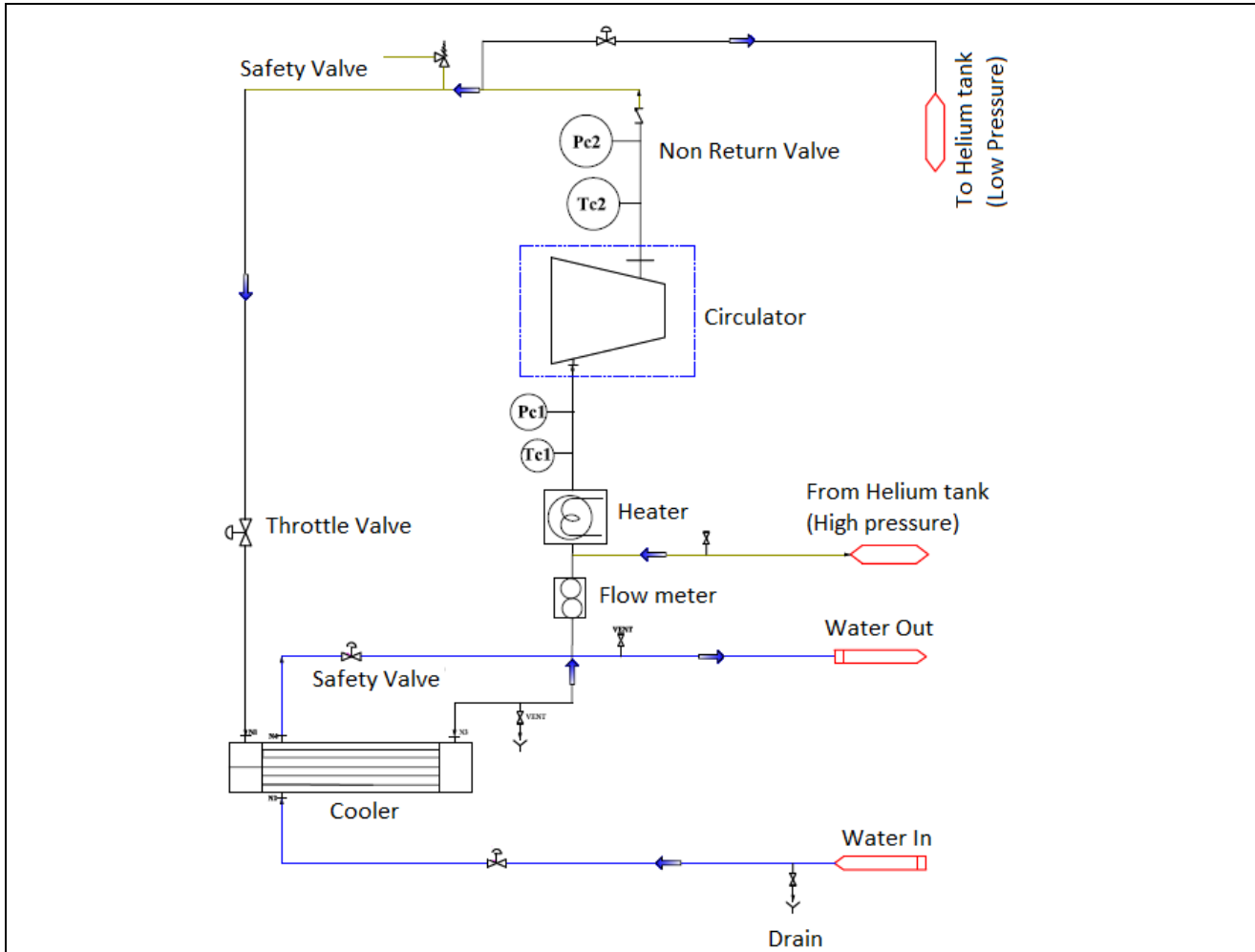

Fig. 2 Circuit Diagram for circulator testing

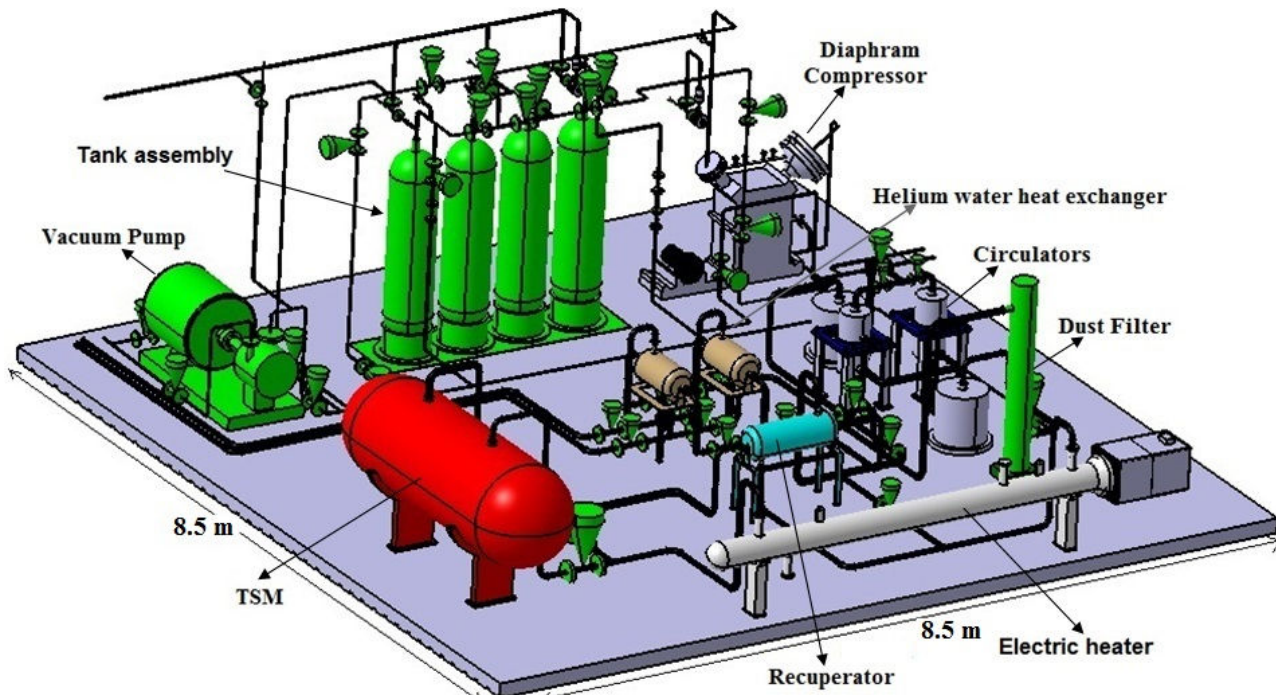

Fig. 3 Model of the EHCL

#### IV. SAFETY FEATURES

To address the safety aspects such as operational safety, investment safety, passive safety and personal safety adequate care has been taken in system design, and further while operation, by following the standard engineering practices and with proper maintenance the safe operation of the loop can be ensured. The operational safety is addressed by selecting proper operational parameters and providing isolations, controls, and fire alarms etc. Provisions of safety and pressure relief valves rupture discs, proper supports to the loop equipments, bypass, use of fail-safe mode philosophy, and provisions of trip and interlocks guard the major equipments of the loop and thus ensure the investment safety. Passive safety is to ensure capability of the system itself to take necessary action without operator interference or electronic feedback; this is achieved by using passive components in the system such as pressure regulators, non-return valves, safety relief valves, pressure relief valves, excess flow check valves etc.

#### V. INSTRUMENTATION & CONTROL SYSTEM

The main controlling parameters of the loop are flow, pressure and temperature. The Instrumentation and Control system of the EHCL is designed to carry out these controls. Interlocks are provided to protect the facility under abnormal condition, trip signals are generated using triplicate signals and using 2of3 logic. For pressure measurement, electronic type pressure transmitter with welded end process connection is provided. For measurement of temperature of Helium gas at Inlet and outlet lines of TSM and Recuperator discharge line towards heater, K type thermocouples are selected. For

accurate flow measurement of Helium gas throughout the circuit, Coriolis Type Mass Flow meter is being considered.

#### VI. EQUIPMENTS INVESTIGATION

The equipments for EHCL shall be selected considering the applicability of these equipments in the ITER LLCB helium cooling loop. The selected equipments shall be appropriate to be used under ITER condition; the equipments shall be scalable and thermo hydraulic and structural integrity shall be maintained and the equipment shall be compact in design. For compressor centrifugal type configuration is selected. For heat exchangers printed circuit type heat exchangers are considered. To reduce leak rate bellow sealed type valve are being considered. Mostly welded constructions are being considered for joining of items and valve connections.

#### VII. CONCLUSION

The proposed Experimental helium cooling loop, EHCL, fulfills the requirements of testing the number of TBM FW mock-ups under different temperature and flow regimes.

Further in the second phase of operation it also caters the requirements of testing the Pb-Li-to-helium heat exchangers. Therefore, successful operations of this loop will back up the design and development of the FW helium cooling system and the Lead Lithium helium cooling system for LLCB TBM. Moreover, it will give experience in operating & control of the high pressure high temperature gaseous helium system.

## REFERENCES

- [1] Indian TBM Design Team, Design Description Document (DDD) for “Lead Lithium Cooled Ceramic Breeder (LLCB) Blanket”, Version 1.0, April 2008.
- [2] Status and progress of Indian LLCB test blanket systems for ITER, Fusion Engineering and Design, Volume 87, Issues 7–8, August 2012, Pages 1009-1013. Paritosh Chaudhuri, E. Rajendra Kumar, A. Sircar, S. Ranjithkumar, V. Chaudhari, C. Danani, B. Yadav, R. Bhattacharyay, V. Mehta, R. Patel, K.N. Vyas, R.K. Singh, M. Sarkar, R. Srivastava, S. Mohan, K. Bhanja, A.K. Suri
- [3] Overview of the ITER TBM Program, Fusion Engineering and Design, Volume 87, Issues 5–6, August 2012, Pages 395-402, L.M. Giancarli, M. Abdou, D.J. Campbell, V.A. Chuyanov, M.Y. Ahn, M. Enoeda, C. Pan, Y. Poitevin, E. Rajendra Kumar, I. Ricapito, Y. Strebkov, S. Suzuki, P.C. Wong, M. Zmitko.
- [4] Paritosh Chaudhuri, C. Danani, V. Chaudhari, C. Chakrapani, R.Srinivasan, I. Sandeep, et al., Thermal-Hydraulic and Thermo-Structural Analysis of First Wall for Indian DEMO Blanket Module, Fusion Engineering and Design 84 (2009) 573–577.
- [5] Analysis of the Reference Accidental Sequence for Safety Assessment of LLCB TBM System, Fusion Engineering and Design, Volume 87, Issues 5–6, August 2012, Pages 747-752. Vilas Chaudhari, Ram Kumar Singh, Paritosh Chaudhuri, Brijesh Yadav, Chandan Danani, E. Rajendra Kumar.
- [6] M. Ionescu Bujor, et al., Helium Loop Karlsruhe (HELOKA): Large Experimental Facility for the In-Vessel ITER and DEMO Components, in: Proceedings of the 20th IAEA Fusion Energy Conference, 2005.