

A Computational Design Algorithm for Manufacturing of Reinforced Structures with Wire Winding

Amer Ezoji, Mohammad Sedighi

Abstract—In the article, the wire winding process for the reinforcement of a pressure vessel frame has been studied. Firstly, the importance of the wire winding method has been explained and literature was reviewed. The main step in the design process is the methodology axial force control. The frame consists of two columns and two semi-cylinders with circumstantial wires. A computational algorithm has been presented based on the governing equations and relations on stress-strain behavior of the whole system of the frame. Then a case study was studied to calculate the frame dimensions and wire winding procedure.

Keywords—Wire winding, Frame, stress, Design for Manufacturing.

I. INTRODUCTION

THE wire winding is one of the useful ways to enhance and control the applied forces to a structure when it's under working pressure. The basic techniques of this method is to create a primary stress to provide remained pressure on the structural wall in order to oppose against the tensile stresses arising from the internal pressure under working conditions which is one of the principles of the enhancing techniques in the winding structures [1].

Enhanced structures by winding include several advantages: The structure safety does not depend on its size, The stress is computable at each point of the winding, The high ratio of resistance to weight due to the thickness of wire layers has the maximum allowed resistance, and also the concentrating stress points and therefore the cracks caused by fatigue will disappear and the cost saving [1]. And also another merits like the excellent resistance to corrosion, easy manufacturing, no limit in size and impact resistance [1].

For the first time in the 19th century, Langrich made use of winding method to enhance the gun rifle and later this method was used in other applications too. In vessel winding analysis mainly based on the assuming of the compound vessel for the tank itself and also assumption and analyzing each wire layer as a thin-wall tank. Fryer analyzed the winding structures in assume of a composite tank and required equations [2]. Various methods has been provided for winding the under pressure vessels and they had individual analyses in order to improve the winding method that each one covered the other one to gain the best method. Langrich [3] executed winding

A.Ezoji is a M.Sc.Graduated from Mechanical Department of Science & Research University, Teheran, Iran (Phone: +989123873591; Fax: +9844493540; e-mail: Amer_e626@yahoo.com).

M.Sedighi is an associate professor in Mechanical Department of Iran Science & Technology University, Hengam Ave, Resalat Square, Teheran, Iran (e-mail: Sedighi@iust.ac.ir).

based on the wire winding tension through all of the layers. Maximov [4] explained that wire winding should be done in a way which the same shear stress applies to all layers. Also in all of the computations the friction between wire layers is ignored by default and it's clear from the previous subjects.

II. THE ANALYSIS OF THE THEORETICAL EQUATIONS IN THE WIRE WINDING FRAME STRUCTURE

In the following we will discuss winding equations in the frame structure by stress analysis on a two columned wire wound frame:

A. Stress Analysis in the Winding Frame Structure

As you see in Fig. 1, in order to control the axial force, the movable caps in an under pressure vessel is used by an open tail frame in two columns which includes two semicircles separated by means of two columns. The yokes and columns have holding structure in pre-stressed wire cover [5]. Column factor affected by the axial force of the columns and direct parts are wound so that:

$$k_c(x, u) = -E_c b / (E_c A_c + E_w b u) \quad (1)$$

$$k_w(x, u) = -E_w b / (E_w A_c + E_c b u) \quad (2)$$

E_w, E_c in order are the elastic module of the wire and column, A_c is the cross section of the column and b is the wire wound width in Fig. 1.

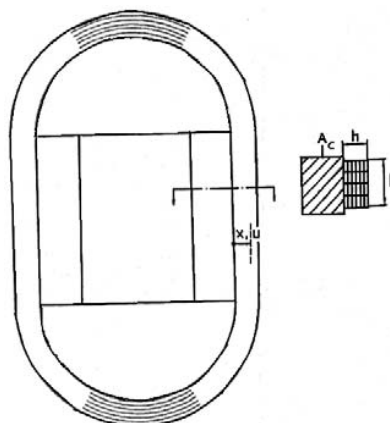

Fig. 1 Wire winding frame structure [5]

Deriving (1) toward x and by placing $S(h) = \sigma(w)$:

$$S(x) = \sigma_w' \left(\frac{E_c A_c + E_w b h}{E_c A_c + E_w b x} \right) \quad (3)$$

Columns pre-stress by placing (2) & (3) in the $f(x) = \int_0^h k(x,u)s(u)d(u)$, we gain a result from winded frame equilibrium:

$$\sigma_c' = -\sigma_w' \frac{bh}{A_c}$$

III. PRESENTING OF THE CALCULATION ALGORITHM AND STRESS EQUATIONS IN THE FRAM STRUCTURE

We will discuss on the calculating algorithm and stress equation in the frame structure form, the vessel by working pressure P, external radius R2 & vessel length Lc. As you see in Fig. 2, the frame structure as a controlling factor of the axial force due to the internal pressure of the vessel includes two columns two up and down Yokes and a winding.

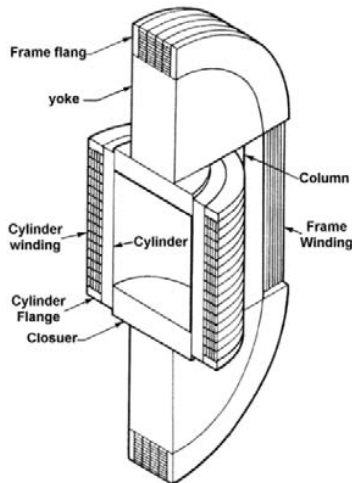

Fig. 2 Reinforced vessel with wire winding frame structure [6]

A. The Calculation of Frame Designing

Required pre-stress according to the ASME [6] standard should be a value which in 105% of hydrostatic test pressure would be mechanically in contact with each other. According to working pressure in the vessel P, the required pre-stress in the frame should be at least 1.25 times more than working pressure multiple to the minimum ratio of material yielding strength using the vessel on the test temperature to the material yielding strength on design desired temperature.

The first assumption to gain the equations in the frame is invariable Yoke radius during loading and winding (rigid body assumption), according to the variable wire layers' lengths using the Fryer Theory [2] the transformation in the wire winding layers are assumed equal. These calculations are performed attending to the shearing stress theory which was presented by Maximov, and the maximum [4] shearing stress

that is generated during using pressure in the wire layers is τ . The goal of this design is to achieve the layers' winding stress for a studying sample; the way going through this design to gain the winding stress is according to Fig. 3.

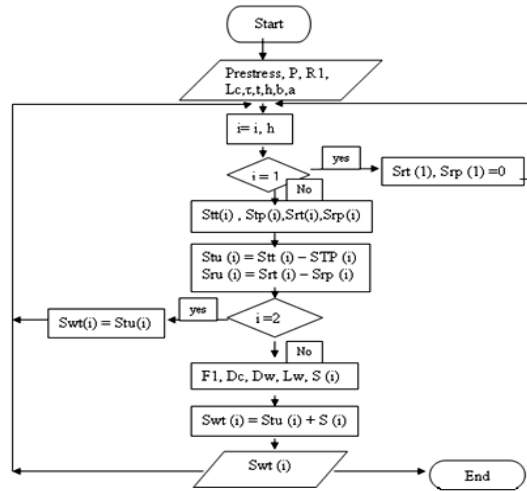

Fig. 3 A Computational design algorithm

B. Working Situation

Working situation is when the frame is under pressure, the pressure due to the tank will affect onto the up & down Yoke and the pressure of the pre stress will be released which in whole wire layers, uniformly shearing stress τ will be created. Assuming the winding frame and pre stress in the columns is created, start from the top layer (Layer 40) and since in this layer the radius stress (S_r) is equal to 0 by using the Treska criterion, the tangential stress of that layer (S_t) is gained:

$$S_t = 2 \times \tau - S_r \quad (4)$$

Then the force out of peripheral stress of this layer is gained:

$$f_2 = S_t \times 2 \times b \times t \quad (5)$$

which t is the width of the layer cross section, b is the winding width. This force out of peripheral stress affects onto the lower layer and from this force we obtain the lower layer peripheral stress:

$$S_{t'} = \frac{f_2}{[2 \times (r_3 - i \times t) \times b]} \quad (6)$$

In this order according to (4), the peripheral stress of this layer and through (6), the radius stress of the lower layer is obtained and by this procedure whole the radius and peripheral stresses from top to bottom layer will be gained.

C. The Frame Situation while We Have Only the Internal Pressure

Under this situation which only the internal pressure is applied to the wire layers and the existence force of the different wire layers contrasts by the vessel pressure. Such as the working situation by assumption the frame winded and by using the super position principle, we start from the top layer and the radius stress in the top layer (layer 40) is zero (S_{rp}) and then you can obtain the length of the same layer when the pressure is applied to in the winding stress of the highest layer is equal to the tangential stress on the highest layer (layer 40th) in no load status, in assumption of eliminating the wire layers from top, the outcome force of the tangential stress is gained in this layer:

$$l_w = 2\pi(r_3 - 0.5 - i) + 2(l_c - 2\delta) \quad (7)$$

R3 is the sum of the external radius of the Yoke and the number of the wires or h, in the layers' number and σ is the changing length through the column which is the outcome of columns pre stress by the winding: summing to omit the effect of this layer force, some of the column length changes are released:

$$\delta = \frac{345 \times l_c}{2 \times E_c} \quad (8)$$

Then by using (8) & (9), peripheral stress of the same layer due to the length varying in the column by that wire layer will be gained the released length change in the same layer is 4 times bigger since the pillar has 4 sides length change:

$$S_{ip} = \frac{4 \times \delta \times E_w - \nu \times S_{rp}}{l_w} \quad (9)$$

Then by means of this tangential stress its outcome force will be gained:

$$f_s = S_{ip} \times 2 \times b \times t \quad (10)$$

This force which affects onto the lower layer and by using this force we can obtain the radius stress of the lower layer:

$$S_{rp} = \left[\frac{f_s}{2 \times (r_3 - i \times t) \times b} \right] \quad (11)$$

And then by means of (8), the length of the lower layer and the peripheral stress of the lower layer, then the peripheral stress of the lower layer will be gained and through this procedure, the peripheral and radius stress of whole layers to the bottom layer will be obtained.

D. Tangential and Radius Stress in the No load Situation of the Vessel

If we subtract the stresses of the status just under the internal pressure from the stresses of working situation we will have the no loaded stresses and in this status the vessel in not under pressure and there is only the pre stress out of winding in the columns.

$$S_{tu}(i) = S_{ti}(i) - S_{ip}(i) \quad (12)$$

$$S_{ru}(i) = S_{ri}(i) - S_{rp}(i) \quad (13)$$

E. The Winding Stresses of the Different Layers

In this status so that the winding stress of top layer is equal to the peripheral stress of the top layer (layer 40) in no load status by assuming of omitting the wire layers from up, we gain the outcome force of the peripheral stress of this layer:

$$f_1 = 2 \times S_{tu} \times b \times t \quad (14)$$

In assumption of omitting the upper layer, this layer force effect will loss and some of the column length varying will be released through the pre stress:

$$D_c = \frac{f_1 \times l_{c2}}{4 \times a \times b_y \times E_c} \quad (15)$$

$$l_{c2} = l_c - 2 \times \delta \quad (16)$$

Released length varying in the same wire layer is 4 times larger because the column length will vary of four sides:

$$D_w = 4D_c \quad (17)$$

$$l_w = 2\pi(r_3 - i + 0.5) + 2(l_c - 2D_c) \quad (18)$$

From (15) & (16), we obtain the stress out of the wire length varying in each layer and by using the length varying in the column in assistance of tangential stress of the no load state will lead to create pre stress in the column. We can gain the stress caused by it, continuing this way and omitting each layer that if we add it to the tangential stress of the same layer, winding stress of each layer is obtained.

$$S = \frac{E_w \times D_w}{l_w} \quad (19)$$

$$S_{wr}(i) = S_{tu}(i) + S(i) \quad (20)$$

IV. STUDYING A SAMPLE FRAME STRUCTURE THE ISOSTATIC SYSTEM

In this part we will analyze the stress in the frame structure of the hot isostatic press system and check a real sample dimensions for a vessel which works in the working pressure of 250Mpa and the external radius of 247mm and the vessel length of 856mm. The wire is used to wind is accorded to the standard ASTM-A905[8] that has a rectangular cross section and the submission stress of 1200 Mpa. The frame structure is made of steel 1/6580 or 1/6582 [7]. From the part A (The calculation of frame designing), the required pre stress in the columns will be 345 Mpa.

A. Presenting the Radial and Tangential Stress

In the working situation and according to the Maximov theory, under applying the internal pressure in the whole wire layers creates the shearing stress of $\tau=400$ Mpa. Using (4) and (6), the radial and tangential stress is shown in Table I:

TABLE I
RADIAL AND TANGENTIAL STRESSES IN THE WORKING SITUATION

Radial stress of 1 st layer	Radial stress of 40th layer	Tangential stress of 1 st layer	Tangential stress of 40th layer
117Mpa	0Mpa	983Mpa	800Mpa

In the situation applying only the internal pressure to the layers using (9) and (11), the radial and tangential stresses are shown in Table II:

TABLE II
RADIAL AND TANGENTIAL STRESSES AND CHANGING LENGTH IN THE INTERNAL PRESSURE

Tangential stress of 40th layer	Tangential stress of 1 st layer	Radial stress of 40th layer	Radial stress of 1 st layer	Changing length of column
144Mpa	148Mpa	0Mpa	23Mpa	0.737mm

In the no load status, the radial and tangential stresses vessel is gained by (12) and (13) which is shown in Table III:

TABLE III
RADIAL AND TANGENTIAL STRESSES IN THE NO LOAD SITUATION

Radial stress of 1 st layer	Radial stress of 40th layer	Tangential stress of 1 st layer	Tangential stress of 40th layer
656Mpa	535Mpa	0Mpa	94Mpa

According to the part E (The winding stresses of the different layers) by (20), winding stress of each layer is gained that after design calculating, winding stress from the high values in the lower layer (692Mpa) descends to lower values in the upper layer (656Mpa) because the internal stress of the lower layers release affecting the pressure of the upper layers.

B. Presenting the Frame Structure Dimensions and the Wire Layers

According to the frame conditions and winding design, should obtain the geometric dimensions in a way which the winding weight and the requirement to the wire layers descend to minimum. By minimizing the required length of the wire and by using the fabricating feasibility of the studying sample, by = 130mm, a = 70mm, b = 120mm, h = 40m will be gained.

V. CONCLUSION

According to the principles of the primary laying stress in this method, this article tries to gain the winding stress of the different winding layers by presenting the relations of the theoretical frame structure and by studying a sample and to Survey as much as possible the issue. The outcome of this article is as following:

1. The best method of wire winding is the constant shearing stress method that the whole wire layers after applying the internal pressure are under a uniform shearing stress.
2. Winding stress in the whole layers is different and according to the frame situation and winding design, the geometric dimensions are obtain in a way which minimizes the winding weight and requirement to the layer.
3. According to the variable layer length, the length change of different layers will be different that if these lengths changes are calculated separately, more accurate response will be gained from the winding stresses.

REFERENCES

- [1] Bahador Arabinejad, "Design, Analysis, Manufacturing Feasibility of Hot Isostatic Pressing Fram", Master Thesis of Mechanical Engineering, Faculty of Mechanical Engineering, Iran University Science and Technology, 2004.
- [2] P. Fryer. High Pressure Vessel Technology, 1987.
- [3] E. H. Young & L. E. Brownell. Process Equipment and design. John Wiley and Sons. 1959.
- [4] L. Yu. Maksimov. "Design of Cylinder to Withstand High Internal Pressure", Russian Engineering Journal (Translation), 1964.
- [5] Gronbaek, J. and Wandheim, T., optimum design of Ribbon and wire wound cylinders for metal forming Dies, journal of Engineering for industry, Aug 1977.
- [6] ASME. Sec. 8. Div3, 2001.
- [7] ASTM A905, 1998.
- [8] Key steel . edi, 1998.