

# The Optimal Indirect Vector Controller Design via an Adaptive Tabu Search Algorithm

P. Sawatnatee, S. Udomsuk, K-N. Areerak, K-L. Areerak, A. Srikaew

**Abstract**—The paper presents how to design the indirect vector control of three-phase induction motor drive systems using the artificial intelligence technique called the adaptive tabu search. The results from the simulation and the experiment show that the drive system with the controller designed from the proposed method can provide the best output speed response compared with those of the conventional method. The controller design using the proposed technique can be used to create the software package for engineers to achieve the optimal controller design of the induction motor speed control based on the indirect vector concept.

**Keywords**—Indirect Vector Control, Induction Motor, Adaptive Tabu Search, Control Design, Artificial Intelligence.

## I. INTRODUCTION

THE induction motor is widely used in industries because it is simple, easy to use, low maintenance, and high efficiency. There are two main control techniques of the induction motor. The first is the scalar method called  $v/f$  constant, while another technique is the vector control. This paper focuses on the vector control techniques because these techniques can directly control torque of the motor. Therefore, the better speed performance can be achieved compared with those of  $v/f$  constant method. As for the vector control method, it consists of two types, namely direct and indirect vector control. The direct vector control uses the rotor flux measurement inside the control process [1], [2]. Hence, the control system becomes more complex. To solve the measurement problem, the indirect vector control [3], [4] is applied to the induction motor drive system, in which the rotor flux can be approximated by using motor parameters.

In addition, it is well known that the artificial intelligence (AI) techniques have widely been applied to many works of engineering such as the system identification using an adaptive tabu search (ATS) [5]-[9], the protection design of the relay via the ATS [10], the active power filter design using a genetic algorithm (GA) [11], power loss minimization using

a particle swarm optimization (PSO) and an artificial bee colony (ABC) [12], reactive power optimization for distribution systems based on an ant colony optimization (ACO) [13]. From the literature reviews, the ATS algorithm has the mathematical proof to confirm that the algorithm can escape the local solutions [7]. Hence, in the paper, the ATS algorithm is selected to design the controller of the indirect vector control of the machine. The expected result is that the best performance in the speed response of the motor will be achieved.

The paper is structured as follows. In Section II, considered power system is firstly explained. In Section III, the controller design using the conventional method is illustrated. The review of ATS algorithm is also addressed in Section IV. The indirect vector controller design using the ATS method is then explained in Section V. The simulation results are fully given in Section VI. Moreover, the experimental result is shown in Section VII to confirm that the proposed design technique can improve speed response compared with the conventional method. Finally, Section VIII concludes and discusses the advantages of the proposed technique for the optimal controller design of the drive systems.

## II. SYSTEM CONSIDERED

The considered power system is depicted in Fig. 1 as a standard motor drive indirect vector control of an induction motor (IM) [14]. The motor is vector-controlled in a rotating dq frame aligned with the rotor flux [14], [15]. For q-axis, there are two PI controllers for the speed loop control (outer loop) and the current loop control (inner loop), while only one PI current loop control is used for the d-axis. Both current loop controllers for dq-axis are identical. The flux of the IM can be controlled via the d-axis. In addition, motor torque and speed can be controlled via the q-axis. The more details of indirect vector control can be found in [14], [15].

This paper presents the application of AI techniques called ATS algorithm to design the controllers for the indirect vector control of Fig. 1. These controllers can provide the better speed performance compared with those using the controller designed from the conventional method. The IM parameters are used for the controller design via the conventional method. These parameters can be determined from the testing. The IM parameters of the machine for the work of this paper are shown in Table I.

P. Sawatnatee is master student in electrical engineering, PEMC research group, School of Electrical Engineering, Suranaree University of Technology Nakhon Ratchasima, 30000, Thailand.

S. Udomsuk is Ph.D. student in electrical engineering, PEMC research group, School of Electrical Engineering, Suranaree University of Technology Nakhon Ratchasima, 30000, Thailand.

K-N. Areerak is lecturer in PEMC research group, School of Electrical Engineering, Suranaree University of Technology, NakhonRatchasima, 30000, Thailand (corresponding author; e-mail: kongpan@sut.ac.th).

K-L. Areerak is lecturer, in PEMC research group, School of Electrical Engineering, Suranaree University of Technology, Nakhon Ratchasima, 30000, Thailand.

A. Srikaew is lecturer in School of Electrical Engineering, Suranaree University of Technology, NakhonRatchasima, 30000, Thailand.

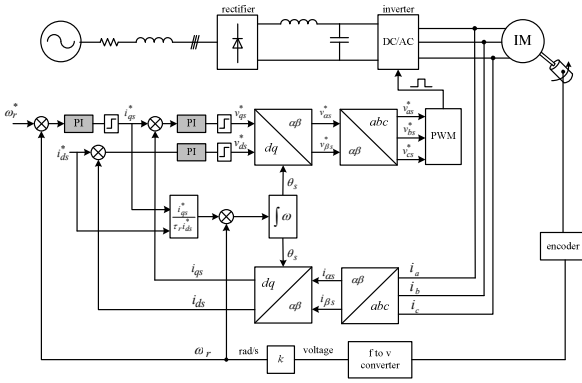

Fig. 1 System considered

 TABLE I  
THE IM PARAMETERS

IM Parameters	Value
$R_s$	25.13 $\Omega$
$L_{ls}$	0.0866 H
$L'_{lr}$	0.0866 H
$L_M$	0.9672 H
$R'_r$	20.79 $\Omega$
$J$	0.0072 Kg.m <sup>2</sup>

### III. CONVENTIONAL METHOD

The details how to design the indirect vector controllers using conventional method are as follow:

The schematic of the current loop control of the system in Fig. 1 is shown in Fig. 2.

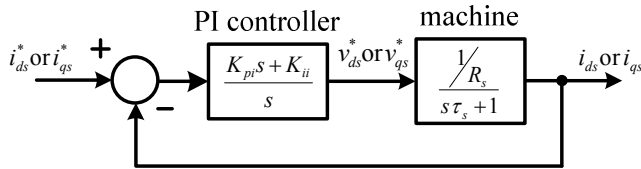

Fig. 2 Block diagram for a current loop

#### A. Current Loop Control

In Fig. 2, the  $K_{pi}$  and  $K_{ii}$  are the PI parameters of current loop control for both d- and q- axis, while  $R_s$  and  $\tau_s$  are the IM parameters as given in Table I. Closed loop transfer function of the current loop is given by (1).

$$\frac{i_{ds}}{i_{ds}^*} = \frac{i_{qs}}{i_{qs}^*} = \frac{(K_{pi}s + K_{ii})/R_s\tau_s}{s^2 + ((R_s + K_{pi})s/R_s\tau_s) + (K_{ii}/R_s\tau_s)} \quad (1)$$

The closed loop denominator has roots with  $\omega_n$  and  $\zeta$ . The standard second order form is

$$D(s) = s^2 + 2\zeta\omega_n s + \omega_n^2 \quad (2)$$

Hence, the current loop controller can be designed by comparing between the denominator of (1) and (2) to yield:

$$\left. \begin{aligned} K_{pi} &= 2\zeta\omega_n \times R_s\tau_s - R_s \\ K_{ii} &= \omega_n^2 \times R_s\tau_s \end{aligned} \right\} \quad (3)$$

where  $\tau_s$  is equal to  $\frac{(L_{ls} + L_M)}{R_s} - \frac{L_M^2}{R_s(L_{ls} + L_M)}$ .

#### B. Speed Loop Control

The schematic of the speed loop control of the system in Fig. 1 is shown in Fig. 3.

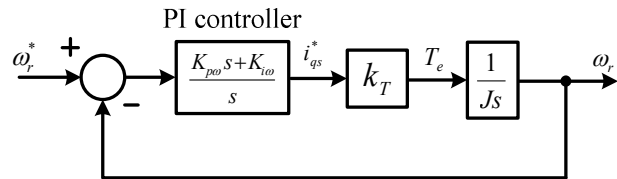

Fig. 3 Block diagram for a current loop

In Fig. 3, the  $K_{p\omega}$  and  $K_{i\omega}$  are the PI parameters of speed loop control, while  $k_T$  and  $J$  are the IM parameters. Closed loop transfer function of the speed loop is given by:

$$\frac{\omega_r}{\omega_r^*} = \frac{k_T(K_{p\omega}s + K_{i\omega})/J}{s^2 + (k_T K_{p\omega}s/J) + (k_T K_{i\omega}/J)} \quad (4)$$

Therefore, the speed loop controller can be also designed by comparing between the denominator of (4) and (2) to yield:

$$\left. \begin{aligned} K_{p\omega} &= 2\zeta\omega_n \times J/k_T \\ K_{i\omega} &= \omega_n^2 \times J/k_T \end{aligned} \right\} \quad (5)$$

where  $k_T = \frac{3}{2} \left( \frac{P}{2} \right) \left( \frac{L_M^2}{L'_{lr}} \right)$

It can be seen in (3) and (5) that the PI controller parameters depends on the IM parameters, in which these parameters used in the paper were determined from the experiment as depicted in Table I.

### IV. ATS ALGORITHM

The ATS algorithm is improved from the Tabu Search (TS) method by adding two mechanisms namely back-tracking and adaptive search radius. The modified version of the TS method has been named the adaptive tabu search of ATS. The ATS algorithm can be outlined as follows:

Step I: Initialize the tabu list  $TL$ , and  $Count$  (a number of search round) = 0.

Step II: Randomly select the initial solution  $S_0$  from the search space.  $S_0$  is set as a local minimum and  $S_0 = best\_neighbor$  as shown in Fig. 4.

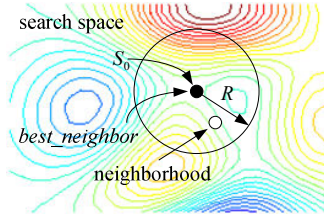

Fig. 4 Random  $S_0$  in search space

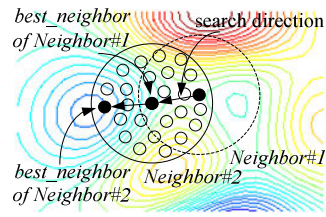

Fig. 8 Searching process in the next iteration

Step III: Update *Count*, then randomly select  $N$  new solutions from the search space of a radius  $R$ . Let  $S_i(r)$  be a set containing  $N$  solutions as shown in Fig. 5

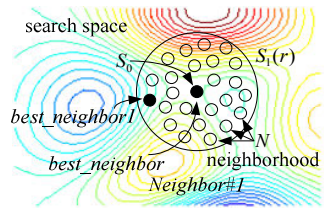

Fig. 5 Neighborhood around  $S_0$

Step IV: Compute the cost value of each member of  $S_i(r)$ . Then, choose the best solution and assign it as  $best\_neighbor1$  (see Fig. 5).

Step V: If  $best\_neighbor1 < best\_neighbor$ , then keep  $best\_neighbor$  in the *TL*, set  $best\_neighbor = best\_neighbor1$  (see Fig. 6), and set  $S_0 = best\_neighbor$  (see Fig. 7). Otherwise, put  $best\_neighbor1$  in the *TL* instead.

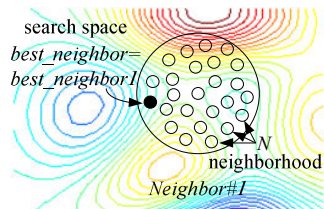

Fig. 6 Assign a new  $best\_neighbor$

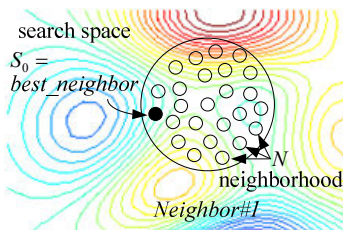

Fig. 7 Assign a new  $S_0$

Step VI: Evaluate the termination criteria (*TC*) and the aspiration criteria (*AC*). If  $Count \geq MAX\_Count$  (the maximum number allowance of search round), stop the searching process. The current best solution is the overall best solution. Otherwise, go back to Step 2 and start the searching process again until all criteria is satisfied (see Fig. 8).

The back-tracking process allows the system to go back and look up the previous solutions in *TL*. The better solution is then chosen among the current and the previous solutions. Fig. 9 illustrates details of the back-tracking process.

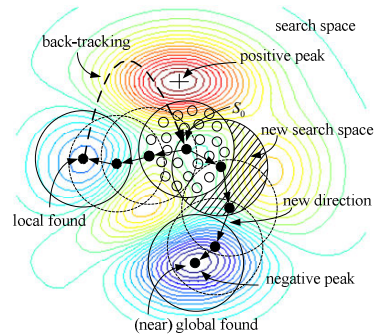

Fig. 9 Back-tracking in ATS algorithm

Given this new search space to explore, the search process is likely to have more chances of escaping from the local optimum. The back-tracking mechanism can be added into Step 5 to improve the searching performance.

The adaptive radius process as depicted in Fig. 10 decreases the search area during the searching process. The adaptive radius mechanism has been developed to adjust the radius ( $R$ ) by using the cost of the solution. The criterion for adapting the search radius is given in (6).

$$radius_{new} = \frac{radius_{old}}{DF} \tag{6}$$

where  $DF$  is a decreasing factor. The adaptive search radius mechanism can be added into the end of Step 6 to improve the searching performance. The more details of ATS algorithm can be found in [7].

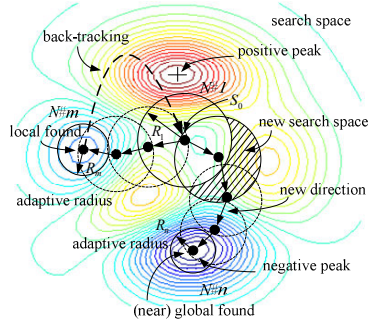

Fig. 10 ATS algorithm with adaptive search radius mechanism

#### V. THE OPTIMAL CONTROLLER DESIGN USING ATS METHOD

In this section, the optimal PI controller design for the IM drive system via the ATS method is illustrated. The ATS algorithms are used to determine the appropriate PI controller parameters, here are  $K_{pi}$ ,  $K_{ii}$ ,  $K_{pow}$  and  $K_{i\omega}$  of both current loop and speed loop controls to achieve the best output performance compared with those designed from the conventional method. The block diagram to explain how to design the PI parameters using ATS algorithm is shown in Fig. 11.

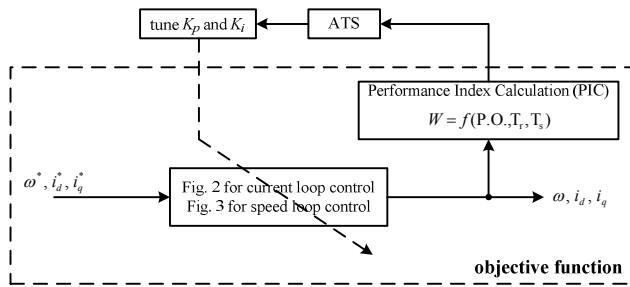

Fig. 11 The ATS algorithm for the PI controller design

In Fig. 11, the ATS algorithm will search the appropriate PI controller parameters. These parameters are used with the block diagram in Figs. 2 and 3 to simulate the system for current loop and speed loop, respectively. The output response of current loop or speed loop is then used to calculate the  $W$  value in which this value represents a performance index for each searched controller parameter determined from the ATS. The ATS will search the appropriate parameters until the minimum value of  $W$  is obtained. It means that the controller parameters from the searching process provide the best performance of the current or speed response. The  $W$  value can be defined by

$$W(T_r, T_s, P.O.) = \sigma T_r + \alpha T_s + \gamma P.O. \quad (7)$$

and

$$\sigma + \alpha + \gamma = 1 \quad (8)$$

where

$P.O.$  is the percent overshoot of the  $v_o$  response.

$T_r$  is the rise time of the  $v_o$  response.

$T_s$  is the setting time of the  $v_o$  response.

$\sigma$ ,  $\alpha$ , and  $\gamma$  are the priority coefficients of  $T_r$ ,  $T_s$ , and  $P.O.$ , respectively.

Note that, in this paper, the values of  $\sigma$ ,  $\alpha$ , and  $\gamma$  are set to 0.34, 0.33, and 0.33, respectively.

According to Fig. 11, the steps of searching controller parameters by using ATS can be summarized as follow:

**Step 1.** Determine the boundary of parameters. In this paper, the upper and lower limits of  $K_{pi}$ ,  $K_{ii}$ ,  $K_{pow}$ , and  $K_{i\omega}$  are set to [10 300], [10000 100000], [0.1 0.5], [1 30], respectively.

**Step 2.** Define the initial value for each parameter by random within the search space.

**Step 3.** Define the radius value ( $R$ ), the one of ATS parameters.

**Step 4.** Define the condition for ATS back tracking.

**Step 5.** Define the cost value, here is  $W$  calculated from (7).

**Step 6.** Define the maximum of searching iteration for ATS ( $count_{max}$ ). This value is set as a stop criterion for ATS algorithm. In this paper, it is equal to 300 iterations. Note that the more details of ATS algorithm can be found in [7].

#### VI. SIMULATION RESULTS

The system of Fig. 1 having the different controllers parameters designed from the ATS and conventional methods was simulated by using SPS<sup>TM</sup> in SIMULINK. The resulting PI controller parameters with their performance index represented by the  $W$  values are given in Table II.

TABLE II  
THE COMPARISON RESULT BETWEEN ATS AND CONVENTIONAL METHODS

PI Controller Parameters	Design Method	
	ATS Method	Conventional Method
$K_{pi}$	299	150
$K_{ii}$	46451	69094
$W_{current\ loop}$	0.4	1
$K_{pow}$	0.5	0.5448
$K_{i\omega}$	14	42.794
$W_{speed\ loop}$	0.6058	1

According to Table II, the controllers designed from the ATS method provide the minimum  $W$  value compared with those of the conventional method. Fig. 12 show the speed response during start-up time to 668 rpm ( $\omega_r^* = 668$  rpm) and taking load torque 1.5 N.m. into the IM at  $t = 1$  s.. The comparison results show that the output responses when the controllers designed by the ATS method are better than that from the conventional method in terms of percent overshoot, rise time and setting time under the changing of command input and taking load.

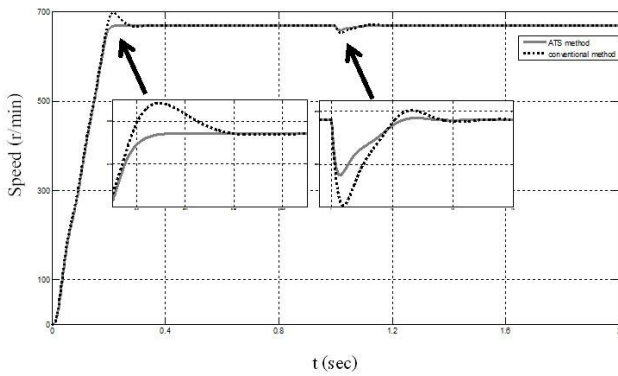
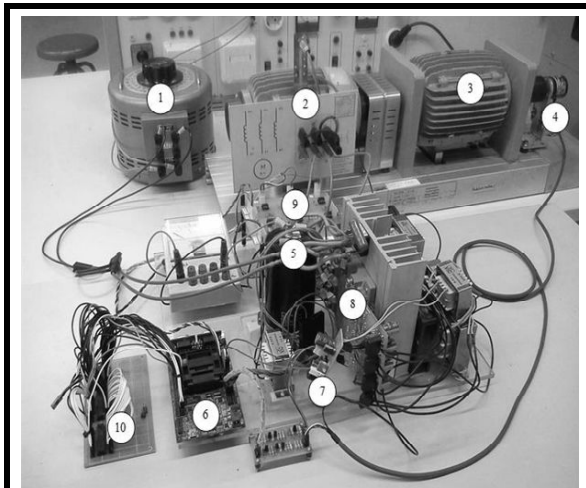

Fig. 12 The comparison results of speed responses between Conventional and ATS methods

### VII. EXPERIMENTAL RESULTS

The test rig of the system in Fig. 1 is shown in Fig. 13. This rig was implemented for the experimental validation.

The controller of the rig was implemented using the DSP eZdsp™ F28335 as shown in the rig in number 6 of Fig. 13. The inverter has been constructed using 50A and 1200 V. The PI controller parameters as shown in Table II were coded in the DSP eZdsp™ F28335. The comparison of the output speed responses between the controllers designed from the conventional and ATS methods for a step change of the speed command  $\omega_r^*$  from 0 rpm to 668 rpm that occurs at  $t = 3$  s. is given in Fig. 14.



- |                                |                            |
|--------------------------------|----------------------------|
| 1. Single-Phase Voltage Source | 6. Indirect-Vector Control |
| 2. Induction Motor             | 7. f to v Converter        |
| 3. Load                        | 8. Inverter                |
| 4. Rotary Encoder              | 9. Current Sensor          |
| 5. Diode Rectifier             | 10. D/A Converter          |

Fig. 13 The testing rig of the system in Fig. 1

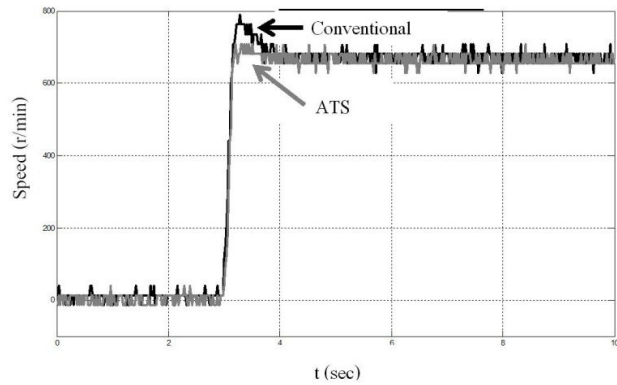

Fig. 14 The results for the experiment validation

The comparison results from the simulation and experiment show that the output speed response when the PI controllers of current and speed loops designed by the ATS method is better than that from the conventional method in terms of percent overshoot, rise time and setting time under the changing of command input and taking load.

### VIII. CONCLUSION

The paper presents the optimal PI controller design for the indirect vector control of IM drive using the ATS algorithm. The resulting output speed responses using the ATS design is better than that of the conventional method for variations in a command input and taking load. The experimental results from the testing rig are also used to support the simulation results. The results show that the proposed design technique is very useful for engineers. The proposed method can provide the best output performance with the stable operation confirmation. Other AI algorithms can also be applied to design the PI controllers of IM drive under the same concept as described in the paper.

### ACKNOWLEDGMENT

This work was supported by Suranaree University of Technology (SUT) and by the office of the Higher Education Commission under NRU project of Thailand. The authors also thank to Assoc. Prof. Dr. Decha Puangdownreong for the useful information of ATS algorithm.

### REFERENCES

- [1] A. Trzynadlowski, *Control of Induction Motors*. San Diego, Calif, London: Academic, 2001.
- [2] K. S. Gaeid, H. W. Ping and H. A. F. Mohamed, "Indirect vector control of a variable frequency induction motor drive (VCIMD)", *International Conference on Instrumentation, Communications, Information Technology, and Biomedical Engineering (ICICI-BME)*, Bandung, 2009, pp.36-40.
- [3] A. Onea, V. Horga, and M. Ratoi, "Indirect Vector Control of Induction Motor", *The 6th WSEAS International Conference on Simulation, Modelling and Optimization (SMO'06)*, Lisbon, Portugal, 2010, pp.98-103.
- [4] S. Prasad, "Indirect Field - Oriented Control of induction motor", *Power Electronics Congress (CIEP), 12th International*, 2010, pp.102 - 105.
- [5] T. Kulworawanichpong, K-L. Areerak, K-N. Areerak, and S. Sujitjorn, "Harmonic Identification for Active Power Filters Via Adaptive Tabu



Search Method”, *LNCS (Lecture Notes in Computer Science)*, Springer-Verlag Heidelberg, vol. 3215, 2004, pp. 687-694.

- [6] T. Kulworawanichpong, K-L. Areerak, K-N. Areerak, P. Pao-la-or, D. Puangdownreong and S. Sujitjorn, “Dynamic parameter identification of induction motors using intelligent search techniques”, *IASTED International Conference on Modelling, Identification, and Control (MIC2005)*, Innsbruck, Austria: February 16-18, 2005, pp.328-332.
- [7] S. Sujitjorn, T. Kulworawanichpong and D. Puangdownreong and K-N Areerak, Adaptive Tabu Search and Applications in Engineering Design, *Book Chapters in Integrated Intelligent Systems for Engineering Design (ed. X. F. Zha and R. J. Howlett)*, IOS Press, The Netherlands, 2006, pp. 233-257.
- [8] D. Puangdownreong, K-N. Areerak, K-L. Areerak, S. Sujitjorn and P. Totarong, “SystemIdentification via Adaptive tabu search”, *In: Proceedings IEEE International Conference on Industrial Technology (ICIT02)*, 2002, pp.915-920.
- [9] D. Puangdownreong, K-N. Areerak, K-L. Areerak, T. Kulworawanichpong and S. Sujitjorn, “Application of adaptive tabu search to system identification”, *IASTED International Conference on Modelling, Identification, and Control (MIC2005)*, Innsbruck, Austria: February 16-18, 2005, pp.178-173.
- [10] K-N. Areerak, T. Kulworawanichpong and S. Sujitjorn, “Moving Towards a New Era of Intelligent Protection through Digital Relaying in Power Systems”, *Lecture Notes in Computer Science*, Springer-Verlag Heidelberg, vol. 3213, 2004, pp. 1255-1261.
- [11] T. Narongrit, K-L. Areerak, and K-N. Areerak, “Design of an Active Power Filter using Genetic Algorithm Technique”, *The 9<sup>th</sup> WSEAS International Conference on Artificial Intelligent, Knowledge Engineering and Data Bases (AIKED'10)*, Cambridge, United Kingdom: February 20-22, 2010, pp.46-50.
- [12] U. Leeton, D. Uthitsunthorn, U. Kwannetr, N. Sinsuphun, T. Kulworawanichpong, “Power loss minimization using optimal power flow based on particle swarm optimization”, *International Conference on Electrical Engineering/Electronics Computer Telecommunications and Information Technology (ECTI-CON)*, Chaing Mai: May 19-21, 2010, pp. 440-444.
- [13] G. Lirui, H. Limin, Z. Ligu, L. Weina, and H. Jie, “Reactive Power Optimization for sidtribution systems based on Dual Population Ant Colony Optimization,” in *Proc. 27<sup>th</sup> Chinese Control Conference (CCC 2008)*, China, pp. 89-93.
- [14] B. K. Bose, *Modern Power Electronics and AC Drives*. New York: Prentice Hall, 2001.
- [15] C-M. Ong, *Dynamic Simulation of Electric Machinery using MATLAB/Simulink*. Upper Saddle River, N. J.: Prentice Hall, 1998.



**P. Sawatnatee** received the B.S. degree in electrical engineering from Suranaree University of Technology (SUT), NakhonRatchasima, Thailand, in 2010, where he is currently studying toward the M.Eng. degree in electrical engineering. His main research interests include modeling of induction motor, vector control, simulation and artificial intelligence applications.



**S. Udomsuk** was born in NakhonRatchasima, Thailand, in 1987. She received the B.Eng. and M.Eng. degrees in electrical engineering from Suranaree University of Technology (SUT), NakhonRatchasima, Thailand, in 2008 and 2011, respectively where she is currently studying toward the Ph.D. degree in electrical engineering. Her main research interests include motor drive, power electronics, AI application and control system.



**K-N. Areerak** received the B.Eng. and M.Eng. degrees from Suranaree University of Technology (SUT), NakhonRatchasima, Thailand, in 2000 and 2001, respectively and the Ph.D. degree from the University of Nottingham, Nottingham, UK., in 2009, all in electrical engineering. In 2002, he was a Lecturer in the Electrical and Electronic Department, Rangsit University, Thailand. Since 2003, he has been a Lecturer in the School of Electrical Engineering, SUT where he is currently an Assistant Professor. His main research interests include artificial intelligence applications, stability analysis of power systems with constant power loads, modeling and control of power electronic based systems, control theory, renewable energy.



**K-L. Areerak** received the B.Eng, M.Eng, and Ph.D. degrees in electrical engineering from Suranaree University of Technology (SUT), Thailand, in 2000, 2003, and 2007, respectively. Since 2007, he has been a Lecturer and Head of Power Quality Research Unit (PQRU) in the School of Electrical Engineering, SUT. He received the Assistant Professor in Electrical Engineering in 2009. His main research interests include active power filter, harmonic elimination, AI application, motor drive, and intelligence control system.



**A. Srikaew** was born in UbolRatchathani, Thailand, in 1972. He received the B.Eng. degree from King Mongkut's Institute of Technology Ladkrabang, Bangkok, Thailand, in 1994 and the M.S. and Ph.D. degrees, both in electrical engineering, from Vanderbilt University, Nashville, TN, in 1997 and 2000, respectively. Since 2000, he has been with the School of Electrical Engineering, Institute of Engineering, Suranaree University of Technology, NakhonRatchasima, Thailand, where he is currently an Associate Professor.