

Micro-Hydrokinetic for Remote Rural Electrification

S. P. Koko, K. Kusakana, H. J. Vermaak

Abstract—Standalone micro-hydrokinetic river (MHR) system is one of the promising technologies to be used for remote rural electrification. It simply requires the flow of water instead of elevation or head, leading to expensive civil works. This paper demonstrates an economic benefit offered by a standalone MHR system when compared to the commonly used standalone systems such as solar, wind and diesel generator (DG) at the selected study site in Kwazulu Natal. Wind speed and solar radiation data of the selected rural site have been taken from national aeronautics and space administration (NASA) surface meteorology database. The hybrid optimization model for electric renewable (HOMER) software was used to determine the most feasible solution when using MHR, solar, wind or DG system to supply 5 rural houses. MHR system proved to be the best cost-effective option to consider at the study site due to its low cost of energy (COE) and low net present cost (NPC).

Keywords—Economic analysis, Micro-hydrokinetic system, Rural-electrification, Stand-alone system.

I. INTRODUCTION

ELECTRIFICATION can play an important role in poverty alleviation within remote rural societies. To improve lives of remote rural societies, an electrical supply method must be affordable and reliable. Lack of access to grid electricity is a major problem in many remote rural areas. Close to 75% of South African rural residents are without electricity [1]. Grid extension is often not economical for remote rural electrification. Sustainable electrification solution for remote rural residents is achieved through renewable energy systems. South African national department of energy (DoE) issued an integrated resource plan (IRP) to increase electricity production from renewable sources to 1.8GW by 2020 [2].

Small-scale standalone energy systems such as solar, wind, micro-hydro as well as diesel generator (DG) are commonly used for remote rural electrification. Apart from conventional hydropower generation, hydrokinetic is a new category of hydropower generation to be used in waterways with little or no elevation. It is a promising technology and still in research and development phase.

Rural areas within South African provinces such as Eastern Cape, Western Cape, Mpumalanga and Kwazulu-Natal have access to flowing water resources. Some rural residents might be situated few kilometers away from flowing water with insufficient elevation. It is impossible to install the traditional hydropower generation in such water flow. Hence, they can relocate closer to such rivers or water resource if they are

aware of potential electrical benefits to be offered by micro-hydrokinetic river (MHR) technology. The selected study site is situated in Kwazulu Natal province at 30.6 latitude South and 29.4 longitude East. This site has numerous renewable energy resources such as permanent water flow, solar and wind.

This study evaluated the economic benefit of applying standalone MHR system to this remote rural area. This economic benefit was then compared to the one offered by other possible standalone systems such as solar, wind and DG. Each standalone system was evaluated to meet the power demand of five rural houses. This enabled the identification of the system offering the cheapest cost of energy production. Hybrid optimization model for electric renewable (HOMER) software was used to present these economic benefits in terms of the net present cost (NPC) and levelized cost of energy (COE). In this study, grid extension was used as a comparison tool for determining the economic distance to the grid.

II. METHODOLOGY

HOMER simulation program was selected as a design tool for enabling the selection of the optimal electrification method. It requires inputs such as resource availability based on climate data, load demand and system components data [3]. Wind speed, solar radiation and clearness index for a yearly period were discovered from national aeronautics and space administration (NASA) surface meteorology database [4]. The comparison of each standalone system was based on meeting the same rural load demand.

A. Load Demand

Load profile is important to study the viability of an electrical power system. To ensure satisfactory quality of life in rural areas, electricity is mainly used for lighting, communication, refrigeration and motor applications [5]. In this study, the estimated load profile is based on supplying a small rural load consisting of five two-roomed houses. It is assumed that each household uses energy efficient appliances such as one radio, one television, one refrigerator, one fan, one washing machine and three lights. Among the three lights, two are used for indoor lighting and one for outdoor lighting. The estimated load profile shown in Fig. 1 is based on the usage of energy efficient appliances revealed in Table I.

S. P. Koko is with the Electrical Engineering Department, Central University of Technology, Free State, South Africa (phone: +2751-507-3517; fax: +2751-507-3254; e-mail: skoko@cut.ac.za).

K. Kusakana and H. J. Vermaak are with the Electrical Engineering Department, Central University of Technology, Free State, South Africa (e-mail: kkusakana@cut.ac.za, hvermaak@cut.ac.za).

TABLE I
24 HOUR LOAD SUMMARY FOR ONE TYPICAL RURAL HOUSEHOLD

Appliances	Quantity	Daily Usage Hours	Common Usage Interval(s)
CFL lights (11W)	3	6	15:00-07:00 18:00-22:00
Radio (10W)	1	12	05:00-17:00
T.V (70W)	1	6	16:00-22:00
Refrigerator (50W)	1	24	00:00-00:00
Fan (6.5W)	1	6	12:00-18:00
Washing Machine (50W)	1	3	09:00-11:00 18:00-19:00

W = watt, CFL = compact fluorescent light

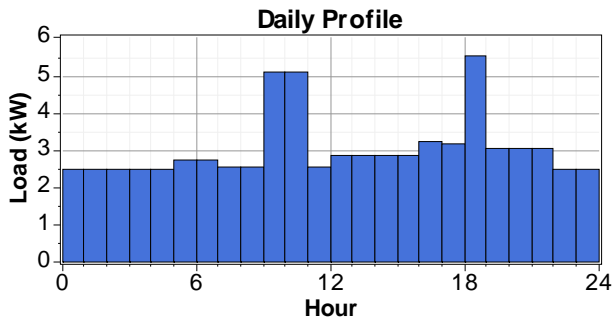

Fig. 1 Rural load profile for 5 rural households

Energy efficient appliances were considered because they influence the amount of power generation required by lowering the investment cost. It is assumed that the load demand is constant throughout the year since the proposed standalone MHR system was not planned to supply appliances such as heaters, electrical kettles, stoves, etc. When excluding the fan, all appliances shown in Table I are usable in all seasons of the year. Hence, summer season is used as a worst case scenario.

From practical point of view, it is impossible for the load to follow the same pattern every day. Hence, HOMER uses random variability to estimate the realistic load demand from the given load profile. This caters for fluctuations which may occur each day within the load profile. In this study, daily variation of 7% and hourly variation of 7% were used for better simulation. To satisfy these variations, HOMER generated a new annual load profile shown in Fig. 2. It consists of the peak load demand of 7.02kW with a scaled annual average energy of 73.1kWh/day.

B. Renewable Energy Resource Assessment

Potential energy of solar, wind and water resources were assessed at the study site. Annual summary of the wind speed, solar radiation and water velocity is shown in Table II [4], [6]. It can be seen that the average solar radiation level of the selected site is 4.97kWh/m²/day. The maximum radiation levels take place during the month of November, December and January. The solar radiation is available throughout the year. Hence, this reveals that the large amount of photovoltaic (PV) power can be obtained in this study area.

TABLE II
SUMMARY OF WATER VELOCITY, SOLAR RADIATION AND WIND VELOCITY AT THE STUDY SITE

Month	Solar radiation (kWh/m ² /day)	Wind speed (m/s)	Water speed (m/s)
January	6.23	4.10	5.31
February	5.83	3.90	7.25
March	5.21	3.80	6.09
April	4.46	3.90	1.81
May	3.81	4.10	2.67
June	3.33	4.50	2.18
July	3.62	4.50	1.84
August	4.29	4.60	1.54
September	5.08	4.80	1.41
October	5.41	4.60	1.69
November	6.00	4.30	2.83
December	6.35	4.00	5.27
Average	4.97	4.26	3.32

kW = kilowatt, h = hour, m = meter, s = second.

The annual average wind speed of the selected site is 4.26m/s at the anemometer height of 10m. The peak wind speeds occur from June to October. The daily wind speed variation (diurnal pattern strength) is 0.25 and the wind speed randomness is 0.85. The annual average water speed of the selected site is 3.32m/s. The flowing water reaches high velocities during January, February, March and December each year.

III. SYSTEM COMPONENTS AND COSTS

System components costs consist of capital, replacement, and operation and maintenance (O&M) costs. The purchasing costs of different technologies can decrease over time at different rates. For a simplified comparison of this study, a worst case scenario was considered by assuming that the replacement costs are equal to the capital costs after the lifespan of each component. The lifetime of the project is assumed to be 25 years. The O&M costs are assumed to be evenly distributed over the entire project lifetime. Other costs such as labor, installation and structures are not included in the simulations. All selected system components are based on meeting the peak demand of 7.02kW. For each standalone system, the battery storage method was included during simulation.

A. Storage Battery and Converter

Battery storage method was preferred to allow storage of excess energy when the load demand is less than the generated energy. Trojan T-105 deep cycle battery was considered for each standalone system. The technical parameters of this battery are shown in Table III. South African market price of purchasing this battery is US\$189 with a lifespan of 5 years when assuming 80% depth of discharge [7]. The O&M cost is estimated to be 2% of the capital cost per year [8]. They are arranged in 4batteries per string to yield 24V DC bus.

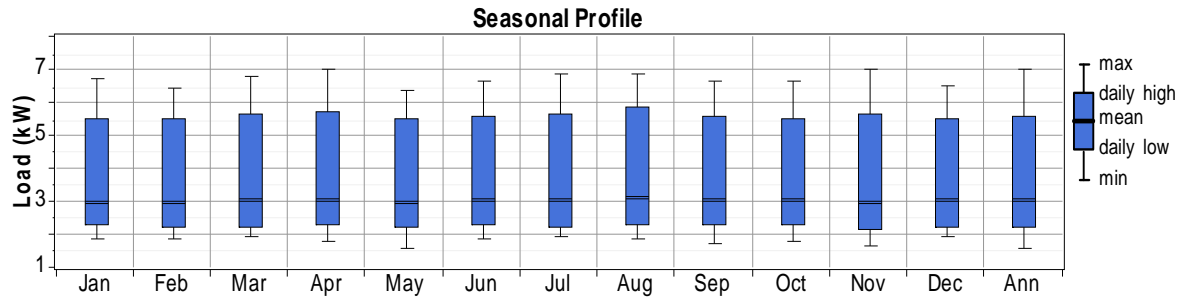

Fig. 2 Monthly load variation profile

TABLE III
TECHNICAL PARAMETER OF TROJAN T-105 BATTERY

Parameter	Value
nominal voltage	6V
nominal capacity	225Ah
maximum charge current	11A
round trip efficiency	85%
minimum state of charge	30%
life-time throughput	845kWh

V = volt, A = ampere, h = hour, kW = kilowatt

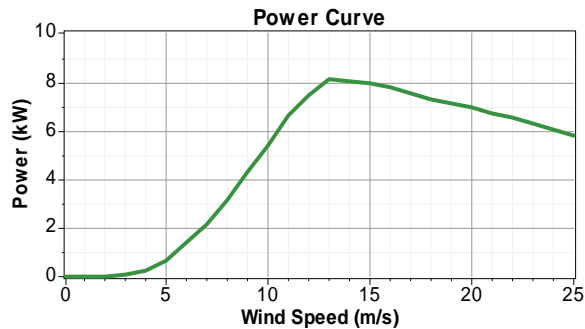

Fig. 3 Power curve of a 7.5kW XLR turbine

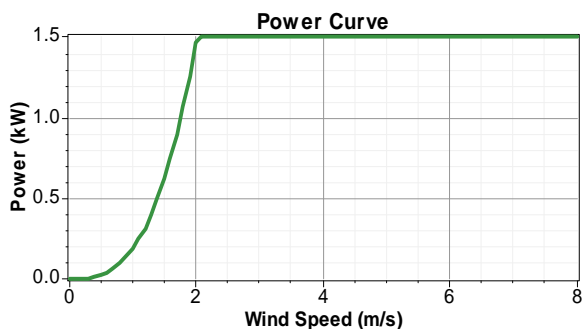

Fig. 4 Power curve of a 1.5kW DHT turbine

A converter has been chosen to vary DC to AC and to charge the battery as well. The chosen converter consists of a battery charger and a standalone true sine wave inverter suitable to supply sensitive electronic appliances as well. It is the 8kW, 50Hz, 230Vac Victron MultiPlus inverter/charger with efficiency of 96%. It can accept different DC voltage ranges such as 9.5-17V_{DC}, 19-33V_{DC} or 38-66V_{DC}. Since the peak load demand of this study is 7kW, this converter can supply up to a maximum of 7.68kW power demand when

considering its efficiency. South African market price of purchasing this converter is US\$5,509 [7]. Its O&M cost is assumed to be 1% of its capital cost per year with a lifespan of 10 years [8].

B. Wind System

Due to wind speed fluctuation, wind turbine system rating is usually higher than the average electrical demand. The data from different manufacturers of wind turbines is already available in HOMER. In this study, a 7.5kW DC XLR wind turbine manufactured by Bergey Wind-power was considered for simulations. The capital cost of purchasing this turbine is US\$24,200 [9]. The lifespan is estimated to be 25 years with the O&M cost being 2% of the capital cost per year [8]. The turbine's power curve at a hub height of 25m is shown in Fig. 3.

C. Hydrokinetic System

HOMER is not equipped with hydrokinetic module. The wind power modules have been used instead since hydrokinetic turbines share lot of similarities with wind turbines. The anemometer height and the turbine hub height were made equal so that HOMER does not scale the wind speed data [10]. A 1.5kW DC Darrieus Hydrokinetic Turbine (DHT) of 1.25m diameter and 1.25m height was chosen for simulation. It is the best choice for small-scale hydrokinetic projects since it can accept low water flow speed for power generation. This turbine was developed by Alternative Hydro Solutions in Canada [11]. The power-curve based on the manufacture's information is shown in Fig. 4. There is no available information regarding the output power at the speed above 2m/s. Hence, it is assumed that at water velocities above 2m/s there is no rise in output power. It requires an investment cost of US\$15,000 [11]. Similar to wind turbine system, the O&M cost is assumed to be 2% of the capital cost per year. The lifespan of this DHT turbine is estimated to be 25 years. The schematic diagram during simulation is shown in Fig. 5.

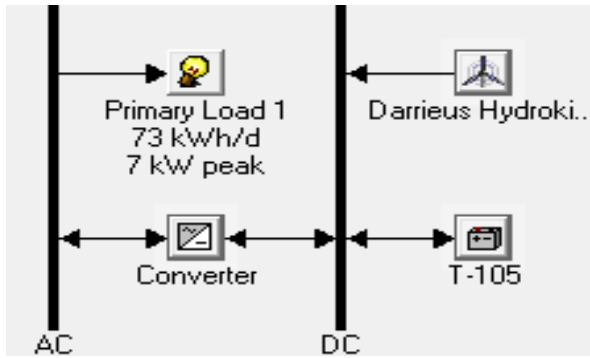

Fig. 5 Schematic diagram of the stand-alone micro-hydrokinetic river system

TABLE IV
GREENHOUSE GASES EMISSION LEVELS DUE TO DIESEL GENERATOR

	DG (Optimum Solution)	DG (Without Battery Banks)
Capital Cost (US\$)	27,984	6,599
NPC (US\$)	293,044	309,426
COE (US\$/kWh)	0.859	0.907
	Emission Levels (kg/year)	Emission Levels (kg/year)
Carbon dioxide	27,919	32,329
Carbon monoxide	68.9	79.8
Unburned hydrocarbons	7.63	8.84
Particulate matter	5.2	6.02
Sulphur dioxide	56.1	64.9
Nitrogen oxide	615	712

US\$ = United States dollar, kW = kilowatt, h = hour, kg = kilogram

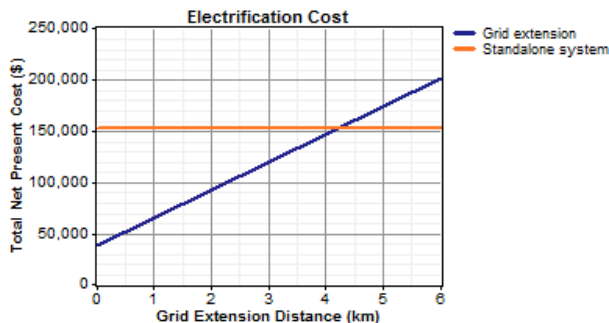

Fig. 6 Breakeven grid extension distance for hydrokinetic system

D. Solar System

The South African market price of purchasing a 1kW polycrystalline PV panel is US\$1321/kW [7]. The O&M cost is considered to be US\$25/kW/year with a lifetime of 20 years. During simulation, HOMER determined the optimum number of solar panels needed to meet the load demand at no electricity shortage.

E. Diesel Generator System

DGs are the commonly used methods of providing

electricity within isolated rural areas. For efficient operation, the user must ensure that the load demand is between 80-90% of DG's rated capacity [12]. The cost of a DG rests on its size. The 8kW, 50Hz, 120/240V_{AC}, Isuzu DG demanding a capital cost of US\$6599 was selected to fulfill the load requirement [13]. The O&M cost is assumed to be US\$0.5/hour with the fuel consumption rate of 0.55liter/kWh. An economic lifespan of a DG is generally 20,000 operating hours [14]. During the study, the South African price of purchasing a diesel fuel was around US\$1.35/liter [15]. Operating a DG is expensive in terms of both fuel and carbon dioxide emission. Hence, the fixed international emission penalty cost of US\$2.25/liter was also taken into account.

F. Grid Extension

The cost of grid extension is needed in order to observe whether a grid extension is more viable compared to the standalone systems. The capital cost of grid extension per kilometer is considered to be US\$8,000/km with the O&M cost of US\$1,500/km/year [16]. During the study, South African local grid electricity price was at US\$0.11/kWh.

IV. RESULTS AND DISCUSSION

After entering all required inputs for each system, HOMER determined the most optimized and cost effective configuration per system. Table V shows the summary of optimal system architecture results for each standalone system during simulation. The annual interest rate of 6% at an expense of offering 0% annual capacity shortage was also considered for each system. All systems were simulated to give a 24-hour electricity service to the same rural load for 8760 hours/year.

Based on results, DG requires the lowest capital cost compared to other standalone systems. HOMER also revealed that if a DG is selected for the study site, it is more economical to use it with the battery banks as shown in Table IV. In addition to the economic benefit, the use of battery banks also minimizes the GHGs emission levels. Nevertheless, according to investment selection criteria DG is not the best option to consider. It does not provide the lowest COE and lowest NPC compared to other standalone systems as shown in Table V. Furthermore, it pollutes the environment by emitting 27,919kg of carbon dioxide gas per year.

Among the three simulated standalone renewable energy systems, solar system requires the lowest capital cost. However, Hydrokinetic is the best system to consider for the study site. It offers the best investment opportunity since it provides the lowest COE of US\$0.445/kWh at the lowest NPC of US\$151,841. Its optimum system configuration consists of 6 DHT turbines, 72 Trojan T-105 batteries and the single 8kW converter. Its breakeven grid extension distance is 4.21 km as shown in Fig. 6. This simply reveals that the total cost of using MHR project for 25 years is equivalent to the cost of installing a grid extension line of 4.21 km length.

TABLE V
SUMMARY OF OPTIMUM SIMULATION RESULTS FOR DIFFERENT STANDALONE SYSTEMS

System	Hydrokinetic	Solar	Wind	DG
Optimal system architecture	DHT (6 turbine) +72 batteries + 8kW converter	PV (42kW) + 204 batteries + 8kW converter	XLR (45kW) + 392 batteries + 8kW converter	DG (8kW) + 84 batteries + 8kW converter
Capital cost (US\$)	109,117	99,547	224,041	27,984
NPC (US\$)	151,841	167,528	346,090	293,044
COE (US\$/kWh)	0.445	0.492	1.015	0.859
Operating cost (US\$/year)	3,342	5,318	9,548	20,735
Annual electricity production (kWh/year)	62,331	60,808	49,510	32,128
Breakeven grid extension distance (km)	4.21	4.78	31.1	9.4
Capacity shortage (%)	0	0	0	0
Carbon dioxide emission (kg/year)	0	0	0	27,919

US\$ = United States dollar, kW = kilowatt, h = hour, km = kilometer, kg = kilogram

V. CONCLUSION

The main goal of the study was to perform the commercial and feasibility analysis of different possible standalone systems within the study site. The study revealed that the best standalone option to consider for the study site is the MHR system since it offers the lowest COE at the lowest NPC. It also offers the highest electricity production of 62,331 kWh per year compared to other studied options. If the local grid is situated more than 4.21km away from the site, it is appropriate to consider MHR system.

Subsequently, one may conclude that the results of this study created the better focus for future research needs based on the following recommendations:

- Analysis of the best hybrid power system that includes hydrokinetic river system in combination with other stand-alone systems.
- Identify more sites with water flow and in close proximity to rural dwellings within other provinces and perform economic feasibility studies for each site.

REFERENCES

- [1] K. Kusakana, J.L. Munda, "Design of a reliable and low-cost stand-alone micro hydropower station (Published Conference Proceeding Style)," *The second IASTED Africa Conference on Power and Energy Systems*, Botswana, 2008, pp. 19–25.
- [2] Department of Minerals and Energy, Republic of South Africa, *Annual Report 2009/2010*. (Accessed: 20 June 2013), Available at: http://www.energy.gov.za/files/Annual%20Reports/DME%20Annual%20Report%2009_10%20hr.pdf
- [3] S. Sunanda, S.S. Chandel, "Review of software tools for hybrid renewable energy systems" *Renewable and Sustainable Energy Reviews*, vol. 32, April 2014, pp. 192–205.
- [4] NASA Surface Meteorology Database, (Accessed: 22 March 2014), Available at: <https://eosweb.larc.nasa.gov/cgi-bin/sse/retscreen.cgi?email=rets@nrcan.gc.ca>
- [5] H. Blennow, "Method for rural load estimations – a case study in Tanzania" Master's Thesis, *Department of Heat and Power Engineering, Lund Institute of Technology*, 2014.
- [6] K. Kusakana, H.J. Vermaak, "Feasibility study of hydrokinetic power for energy access in rural South Africa (Published Conference Proceeding Style)," *Fifth IASTED Asian Conference on Power and Energy Systems*, April 2012, pp. 433–438.
- [7] Alternagy, (Accessed: 20 April 2014), Available at: <http://www.alternagy.co.za/>
- [8] A. Hiendro, R. urmianto, M. Rajagukguk, Y.M. Simanjuntak, Junaidi, "Techno-economic analysis of photovoltaic/wind hybrid system for onshore/remote area in Indonesia" *Energy*, vol. 59, September 2013, pp.652–657.
- [9] ABS Alaskan, "Excel 7.5kW high voltage DC turbine" (Accessed: 29 March 2014), Available at: http://www.absak.com/catalog/product_info.php/cPath/32_93_107/products_id/146
- [10] HOMER Energy Support, "10177-Modeling a hydrokinetic turbine in HOMER" (Accessed: 31 March 2014), Available at: <http://support.homerenergy.com/index.php?/Knowledgebase/Article/View/136/50/10177---modeling-a-hydrokinetic-turbine-in-homer>
- [11] Alternative Hydro Solutions, (Accessed: 01 April 2014), Available at: <http://www.althydro.com/>
- [12] NasefAbd El-Shafy, "Proposed technique for optimally sizing a PV/diesel hybrid system" *International Conference on Renewable Energies and Power Quality*, March 2010.
- [13] Generator Sales, (Accessed: 20 April 2014), Available at: <http://www.generatorsales.com/diesel-generators.asp>
- [14] S. Rehman, M.M. Alam, J.P. Meyer, L. Al-Hadhrami, "Feasibility study of a wind-PV-diesel hybrid power system for a village" *Renewable Energy*, vol. 38, February 2012, pp.258–268.
- [15] M. Lu, C. Chang, W. Lee, L. Wang, "Combining wind power generation system with energy storage equipments" *IEEE Transactions on Industry Applications*, vol. 45, November 2009, pp.2109–2115.
- [16] R. Sen, S. C. Bhattacharyya, "Off-grid electricity generation with renewable energy technologies in India: an application of HOMER" *IEEE Transactions on Industry Applications*, vol. 62, February 2014, pp.388–398.