

A PI Controller for Enhancing the Transient Stability of Multi Pulse Inverter Based Static Synchronous Series Compensator (SSSC) With Superconducting Magnetic Energy Storage (SMES)

¹S. Padma, ²Dr. R. Lakshmi pathi, ³K. Ramash Kumar and ⁴P. Nandagopal

Abstract—The power system network is becoming more complex nowadays and it is very difficult to maintain the stability of the system. Today's enhancement of technology makes it possible to include new energy storage devices in the electric power system. In addition, with the aid of power electronic devices, it is possible to independently exchange active and reactive power flow with the utility grid. The main purpose of this paper proposes a Proportional – Integral (PI) control based 48 – pulse Inverter based Static Synchronous Series Compensator (SSSC) with and without Superconducting Magnetic Energy Storage (SMES) used for enhancing the transient stability and regulating power flow in automatic mode. Using a test power system through the dynamic simulation in Matlab/Simulink platform validates the performance of the proposed SSSC with and without SMES system.

Keywords—Flexible AC transmission system (FACTS), PI Control, Superconducting Magnetic Energy Storage (SMES), Static Synchronous Series Compensator (SSSC).

I. INTRODUCTION

ONE of the most important requirements during the operation of the electric power system is the reliability and security. This concept is related to the system capability of maintaining its operation in case of an unexpected failure of some of its components (e.g.: lines, generators, transformers, etc.). Hence, the necessity of having available enough “short-term generation reserve” in order to preserve acceptable security levels is derived. This reserve must be appropriately activated by means of proper control in order to keep the system in safe conditions during the transient. Otherwise, serious problems could occur in the

utility system. Nowadays, the new Energy Storage System (ESS) is a feasible alternative to decrease the reserve power of generators. By using proper energy storage devices, excess energy may be stored to substitute the power reserve of generators during the action of the primary frequency control.

In this sense, research in this field has been lately extended with the aim of incorporating power electronic devices into electric power systems. The goal pursued is to control the operation of the power system, a fact which clearly affects the operation security. In bulk power transmission systems, power electronics-based controllers are frequently called Flexible AC Transmission Systems (FACTS) [1]. Presently, these devices are a viable alternative as they allow controlling voltages and currents of appropriate magnitude for electric power systems at an increasingly lower cost.

While the FACTS/SMES combination has been proposed in theory and the development of this FACTS/SMES combination has lagged far behind that of FACTS alone [2]. Significant interest has been given to developing control strategies for a variety of FACTS devices in order to mitigate a wide range of potential bulk power transmission problems have been reported [3]. However, a comparable field of knowledge on FACTS/ESS control is quite limited. Therefore, in this work a methodology is proposed to control the power flow, which uses FACTS controllers with energy storage. Using switching power converter-based FACTS controllers can carry this out. Among the different modeling of FACTS devices, Static Synchronous Series Compensator (SSSC) is proposed as the most adequate for the present application well discussed [4]. The DC inner bus of the SSSC allows incorporating a substantial amount of energy storage in order to enlarge the degrees of freedom of the SSSC device and also to exchange active and reactive power with the utility grid. Based on a previous study of all energy storage technologies currently available, the use of Superconducting Magnetic Energy Storage system (SMES) is proposed for the considered application has been presented in [5]-[6].

This paper proposes a model of an SSSC with and without SMES, and a PI control algorithm for this combined system to carry out the power flow control of the electric system. This paper also lays the foundations for an increased operational flexibility by integrating energy storage devices

¹S. Padma is with the Sona College of Technology, Salem-5, Tamilnadu, India, (phone: +91-9942584848; fax: +91-4274099888; e-mail: swanisha@gmail.com).

²Dr. R. Lakshmi pathi was with the Government College of Engineering, Karaikudi, Tamilnadu, India. He is now with the Department of Electrical & Electronics, St. Peter's Engineering College, Chennai, Tamilnadu, India. (e-mail: drlakshmi pathi@yahoo.co.in).

³K. Ramash Kumar is with the Department of Electrical and Electronics Engineering, A.M.S. College of Engineering, Anna University, India. (e-mail: ramash1210@yahoo.co.in).

⁴P. Nandagopal is pursuing his post graduation in power system engineering in Sona College of Technology, Salem, Tamilnadu, India, (e-mail: nanda_6110@yahoo.co.in).

with other power converter-based FACTS controllers structures, i.e. Unified Power Flow Controllers (UPFC). Details on operation, analysis, control strategy and simulation results for SSSC with and without SMES are presented in the subsequent sections.

II. SSSC INTEGRATED WITH SMES

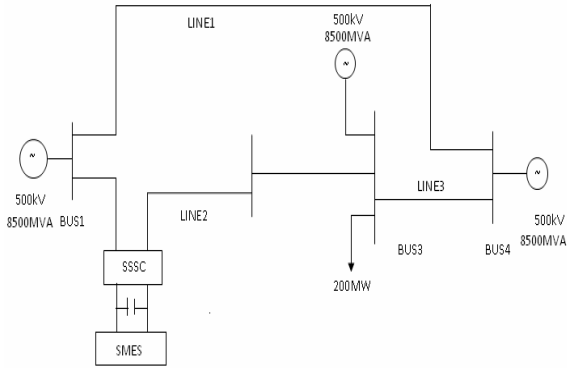

Fig. 1 Single line diagram of the test system with SSSC

SSSC is a voltage sourced converter based series compensator. The compensation works by increasing the voltage across the impedance of the given physical line, which in turn increases the corresponding line current and the transmitted power. For normal capacitive compensation, the output voltage lags the line current by 90°. With voltage source inverters the output voltage can be reversed by simple control action to make it lead or lag the line current by 90°. The addition of energy storage device is helpful in exchanging the real power. A superconducting magnetic energy storage containing electronic converters rapidly injects and/or absorbs the real and/or reactive power or dynamically controls the power flow in an ac system. Since the dc current in the magnet does not change rapidly, the power input or controlling the voltage across the magnet with a suitable electronics interface changes output of the magnet. The single line diagram of the test system used for the simulation study is shown in Fig. 1. Novel reactive power controllers for STATCOM and SSSC have been reported [7].

III. 48 – PULSE VOLTAGE SOURCE INVERTER (VSI)

A 48-pulse voltage source inverter is used for the proposed work. With 48 - pulse VSI, AC filters are not required. Fig. 2 shows the connection diagram of the 48 – pulse VSI. Here, ideal switches and zigzag phase shifting transformers are used to build a GTO-type voltage source inverter. The inverter described is harmonic neutralized. It consists of four 3-phase, 3-level inverters and four phase-shifting transformers. The DC bus is connected to the four

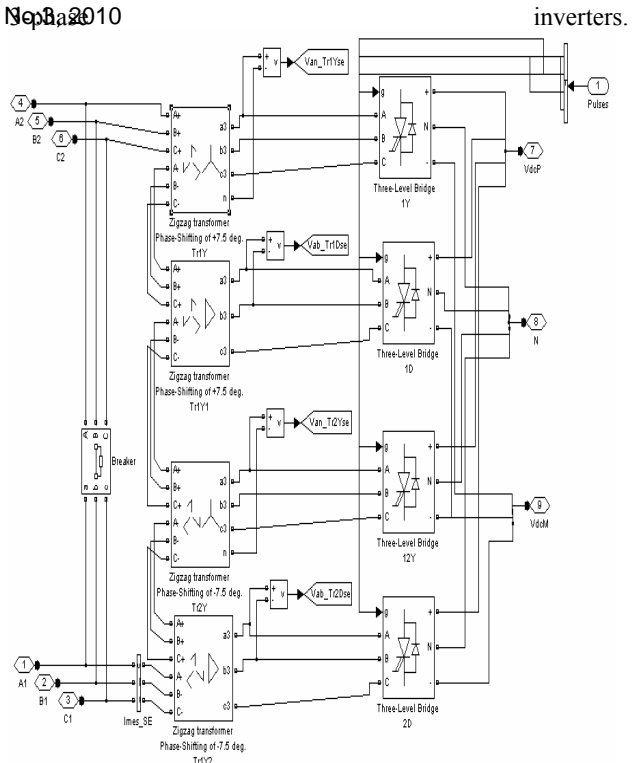

Fig. 2 48 – Pulse voltage source inverter

The four voltages generated by the inverters are applied to secondary windings of four zigzag phase-shifting transformers connected in Wye (Y) or Delta (D). The four transformers' primary windings are connected in series and the converter pulse patterns are phase shifted so that the four voltage fundamental components sum in phase on the primary side. The phase shifts produced by the secondary delta connections (-30 degrees) and by the primary zigzag connections (+7.5 degrees for transformers 1Y and 1D, and -7.5 degrees for transformers 2Y and 2D) allow neutralizing harmonics up to 45th harmonic.

$$V_{ab_{48}}(t) = 8 \sum_{m=1}^{\infty} V_{ab_{48}} \sin(m\omega t + 18.75^{\circ} m + 11.25^{\circ} t) \quad (1)$$

$$V_{an_{48}}(t) = \frac{8}{\sqrt{3}} \sum_{m=1}^{\infty} V_{an_{48}} \sin(m\omega t + 18.75^{\circ} m - 11.25^{\circ} t) \quad (2)$$

Where,

$$V_{ab_{48}} = \frac{4}{m\pi} V_{DC} \cos \frac{\pi}{6} m \quad (3)$$

$$V_{an_{48}} = \frac{4}{3m\pi} V_{DC} (1 + \cos \frac{\pi}{3} m) \quad (4)$$

$m = 48r \pm 1, r=0, 1, 2, \dots$

$i=1$, for positive sequence harmonics

$i=-1$, for negative sequence harmonics

The voltages $V_{bc_{48}}$ and $V_{ca_{48}}$ exhibit a similar pattern except phase shifted by 120° and 240° respectively. Similarly, the phase voltages $V_{bn_{48}}$ and $V_{cn_{48}}$ are also phase shifted by 120° and 240° respectively.

III. DC-DC CHOPPER

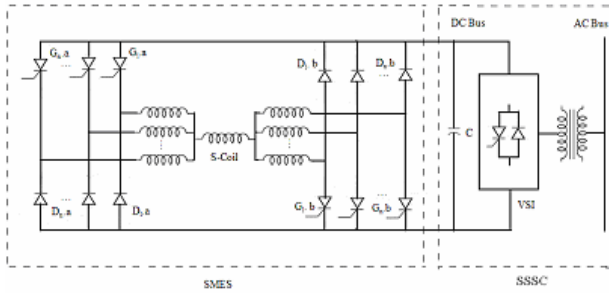

Fig. 3 Circuit diagram of chopper

An electronic interface known as chopper is needed between the energy source and the VSI. For VSI the energy source compensates the capacitor charge through the electronic interface and maintains the required capacitor voltage. Two-quadrant n-phase DC-DC converter as shown in Fig. 3 is adopted as interface. Here 'n' is related to the maximum current driven by the superconducting device. The DC-DC chopper solves the problems of the high power rating requirements imposed by the superconducting coil to the SSSC. The DC-DC chopper allows to reduce the ratings of the overall power devices by regulating the current flowing from the superconducting coil to the inverter of the SSSC [9].

The two quadrant multi-phase chopper is composed of many shunt connected diode-thyristor legs that permit the driving of the high current ratings stored in the superconducting coil. The chopper has three modes of operation to perform the charge, the discharge and the storage in the SMES device. The chopper is operated in a step down configuration in the charge mode of the superconducting coil. Here, the set of thyristors "a" are operated with the duty cycle 'D' while the set of thyristors "b" are kept on at all times. The relationship between the coil voltage and the DC bus voltage is given by the equation,

$$V_{SEMS} = D * V_{DC} \quad (5)$$

Once the charging of the superconducting coil is completed, the operating mode of the DC-DC converter is changed to the stand-by mode for which the set of thyristors "a" are kept off all the time while the set of thyristors "b" are kept on constantly.

In the discharge mode, the chopper is operated in a step-up configuration. The set of thyristors "b" is operated with duty cycle D while the set of thyristors "a" is kept off at all times. The relationship between the coil voltage and the DC bus voltage is given by the equation

$$-V_{SEMS} = (1 - D) * V_{DC} \quad (6)$$

The duty cycle ranges from 0 to 1. The relationship between the DC bus voltage and the output voltage of the inverter is given by the Eq. (7)

$$V_{DC} = k_a |V_{inv}| \quad (7)$$

Where,

$$k_a = k * a$$

V. CLOSED LOOP CONTROL SCHEME FOR SSSC

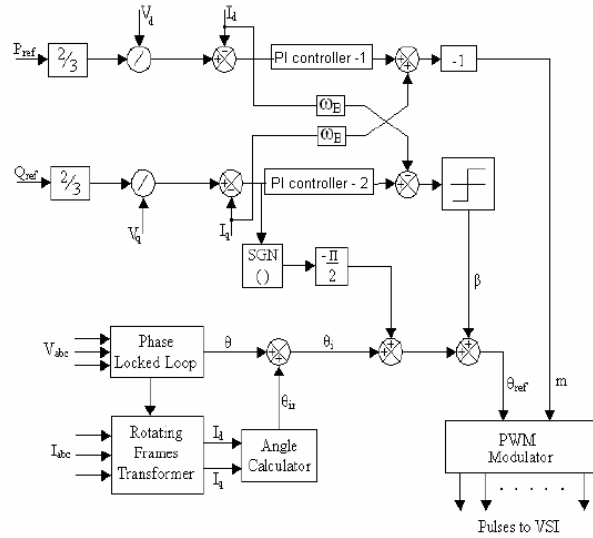

Fig. 4 SSSC closed loop control scheme

The main function of the SSSC is to dynamically control the power flow over the transmission line. The control scheme proposed by [9] is based on the line impedance control mode in which the SSSC compensating voltage is derived by multiplying the current amplitude with the desired compensating reactance X_{qref} . Since it is difficult to predict X_{qref} under varying network contingencies, in the proposed scheme, this controller is modified as shown in Fig. 4 to operate the static synchronous series compensator in the automatic power flow control mode. Investigations of Performance of UPFC without DC link capacitor [10]. In this mode, the reference inputs to the controller are P_{ref} and Q_{ref} , which are to be maintained in the transmission line despite system changes. The instantaneous power is obtained in terms of d-q quantities as:

$$P = \frac{3V_d I_d}{2} \quad (8)$$

$$Q = \frac{3V_q I_q}{2} \quad (9)$$

From equations (8) and (9), the required current references are calculated as follows:

$$I_{dref} = \frac{2P_{ref}}{3V_d} \quad (10)$$

$$I_{qref} = \frac{2Q_{ref}}{3V_d} \quad (11)$$

The line current I_{abc} and the line voltage V_{abc} are sensed at the point B2 on the transmission line of Fig. 1 and are converted into d-q components using Parks' transformation. The desired current references namely I_{dref} and I_{qref} are

compared with actual current components I_d and I_q , respectively and the error signals are processed in the PI controller. The comparative study of different controller for power converter and PI controller parameters are designed by Ziegler Nichols's PI tuning method detailed discussion in [11]-[12]. The PI controller parameters set for this process is shown in Table I. Based on these controller parameters set, the required small displacement angle β to control the angle of the injected voltage with respect to the line current has been derived. A Phase Locked Loop (PLL) is used to determine the instantaneous angle θ of the three-phase line voltage V_{abc} . The current components I_d and I_q of the three phase line currents are used to determine the angle θ_{ir} relative to the voltage V_{abc} . Depending upon the instantaneous reactive power with respect to the desired value, either $\pi/2$ is added (inductive) or subtracted (capacitive) with β . Thus, the required phase angle is derived as $\theta_{ref} = \theta + \theta_{ir} + \beta \pm (\pi/2)$. The modulation index m derived from the active power control part of the circuit and the phase angle θ_{ref} are applied to the PWM modulator to generate the SSSC compensating voltage. Using θ_{ref} and m , the fundamental component of PWM inverter output voltage is obtained as Eq. (12) follows:

$$V_{\sin e} = m \sin(2\pi ft - \theta_{ref}) \tag{12}$$

TABLE I
PI CONTROLLER PARAMETERS

Symbol	Value
Kp	0.025
Ki	6

VI. INTERNAL CONTROL SCHEME FOR SSSC WITH SMES

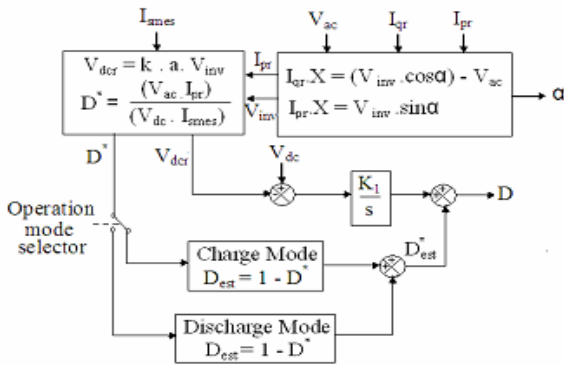

Fig. 5 Internal control scheme for SSSC with SMES

For generating the gating pulses for VSI and the DC-DC chopper, internal control block is designed. Fig. 5 shows the internal control scheme for proposed system. Dynamic response of power conditioning systems for super conductive magnetic energy Storage has been reported [13]. The control scheme includes the decoupled control for the real and reactive power. The two independent reference signals are the reactive current and the active current. From these reference signals the amplitude and phase ratings of the voltage at the VSI is determined. The duty cycle D is estimated from the active power ratings that the SSSC should inject from the voltage at the DC bus and from the current stored into the SMES coil. This estimated value of

is eliminated through a closed loop control whose function is eliminating the voltage error between the calculated and the real voltage ratings at the DC bus.

VII. SIMULATION RESULTS AND DISCUSSIONS

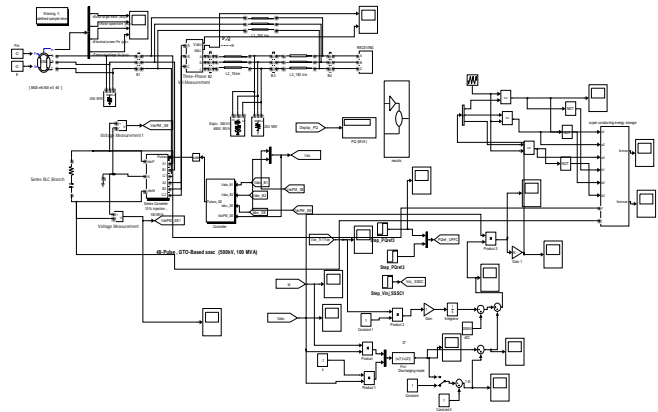

Fig. 6 Simulation model

The PI control is applied for two cases (a) and (b). Case (a) is discussed for the PI control for 48-pulse inverter based SSSC without SMES and case (b) is discussed for the PI control for 48-pulse inverter based SSSC with SMES and are simulated using MATLAB/Simulink to analyze its operation. The specification of the proposed test system is listed in Table II. The Matlab/Simulink simulation model for case (a) and case (b) as shown in Fig. 6. The various transient disturbances due to faults and step change variation in power are created to study the performance of the PI control for SSSC with and without SMES. The VSI output voltage and the corresponding THD for case (a) are shown in Figs. 7 and 8.

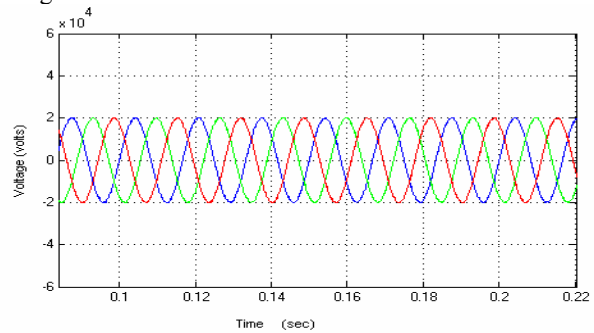

Fig. 7 48-Pulse VSI output voltage for case (a)

In Fig. 9 the VSI is found to generate a voltage of desired magnitude and phase angle, which is to be injected in series with the transmission line. This series injected voltage lags behind the line current and thereby provides capacitive compensation.

TABLE II
SPECIFICATION OF TEST SYSTEM

Parameters	Values
Rated voltage	500 kV
MVA SSSC	100 MVA
Base voltage	500 kV

Resistance	0.1 p.u
Reactance	0.3 p.u
Transmission line X_L	0.25 p.u
Transmission line R_L	0.05 p.u
D.C voltage	20 kV
Rated power	70 MVAR
D.C capacitance	2000 μ F
Series transformer rated voltage	20 kV/ 500 kV
SMES (Inductance)	2 H

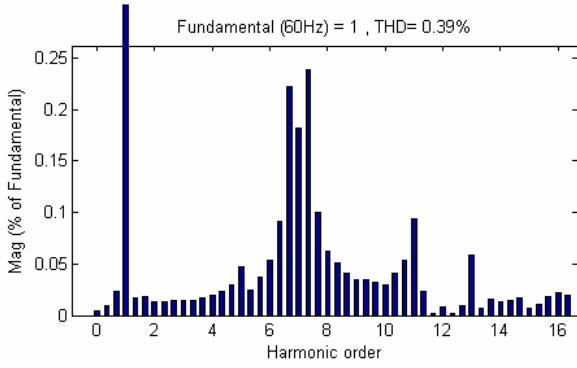

Fig. 8 48-Pulse VSI output voltage THD for case (a)

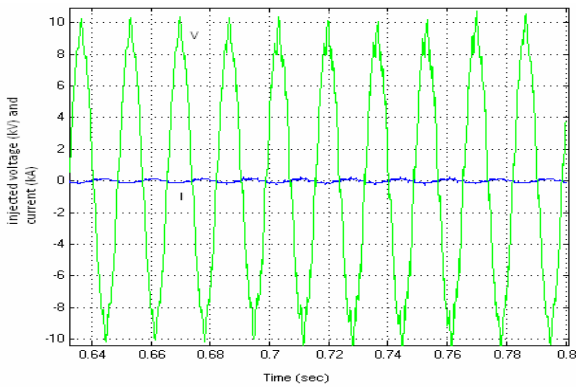

Fig. 9 SSSC injected voltage and current for case (a)

Fig. 10 and Fig. 11 show the reference and measured value of real and reactive power for SSSC with PI control (case a). It can be seen that the P_{ref} is initially at 0.87 p.u and changes to 0.93 p.u at time 0.25 s and Q_{ref} changes from -0.6 to 0.1 p.u at time 0.5 s. The transmission line current and voltage are shown in Fig. 12.

The VSI output voltage and the corresponding THD for case (b) are shown in the Fig. 13 and Fig. 14. It could be found that THD as well as the VSI output voltage point of view the performance of PI control for SSSC with SMES is better compared to PI control for SSSC without SMES as in Fig. 7 and Fig. 8.

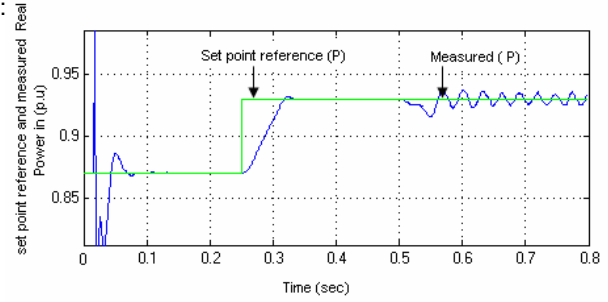

Fig. 10 Real power flow over the transmission line for case (a)

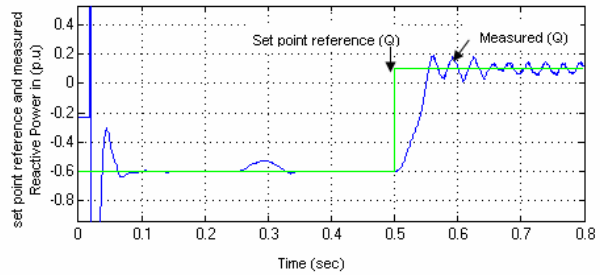

Fig. 11 Reactive power flow over the transmission line for case (a)

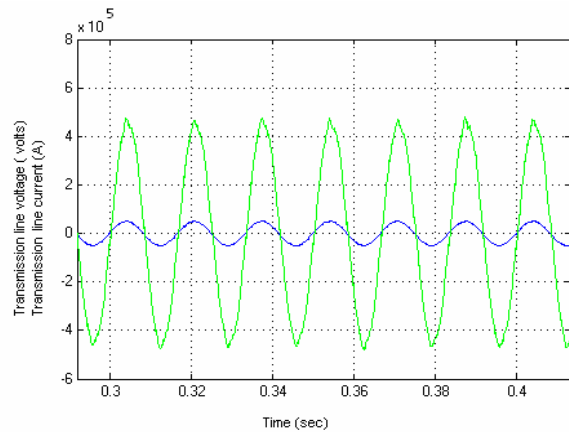

Fig. 12 Transmission line voltage and current for case (a)

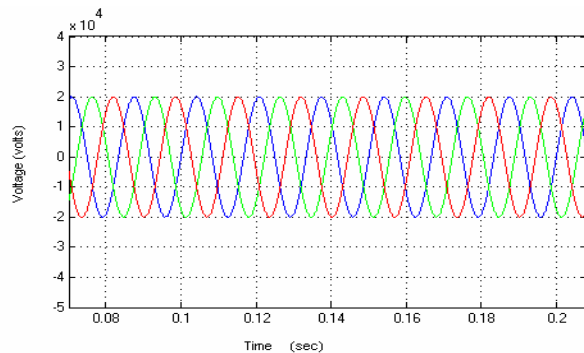

Fig. 13 48-Pulse VSI output voltage for case (b)

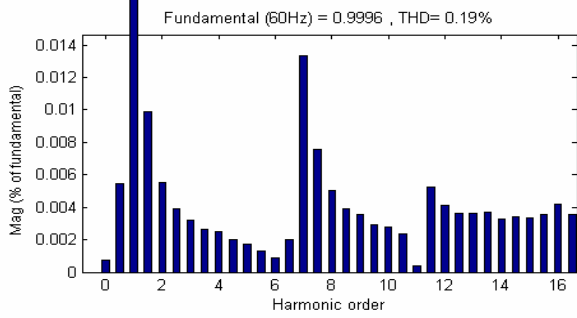

Fig. 14 48-Pulse VSI output voltage THD for case (b)

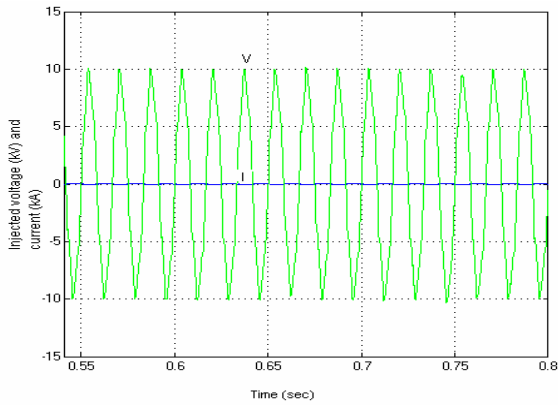

Fig. 15 SSSC injected voltage and current for case (b)

In Fig. 15 the VSI is found to generate a voltage of desired magnitude and phase angle, which is to be injected in series with the transmission line. It can be seen that from the injected voltage as well as current point of view, the performance of PI control for SSSC with SMES is better compared to PI control for SSSC without SMES as in Fig. 9.

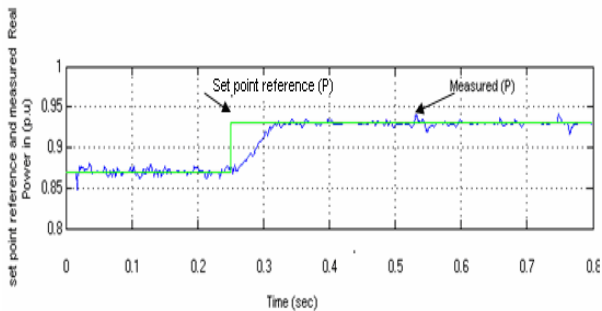

Fig. 16 Real power flow over the transmission line for case (a)

Figs. 16 and Fig. 17 show the reference and measured value of real and reactive power of PI control for SSSC with SMES. It can be seen that the P_{ref} is at 0.87 p.u initially and changes to 0.93 p.u at time 0.25 s and Q_{ref} changes from -0.6 to 0.1 p.u at time 0.5 s. It is clear from both the figures that performance of PI control for SSSC with SMES is better compared to PI control for SSSC without SMES as in Fig. 10 and Fig. 11 at different set point power reference variations.

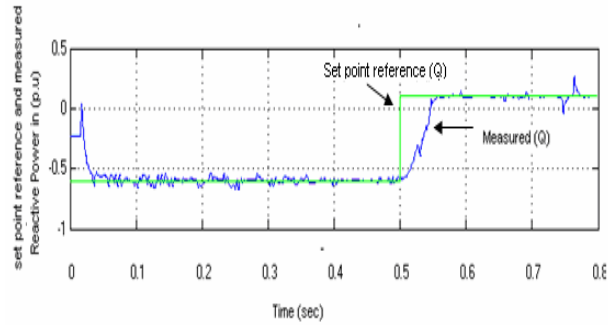

Fig. 17 Reactive power flow over the transmission line for case (b)

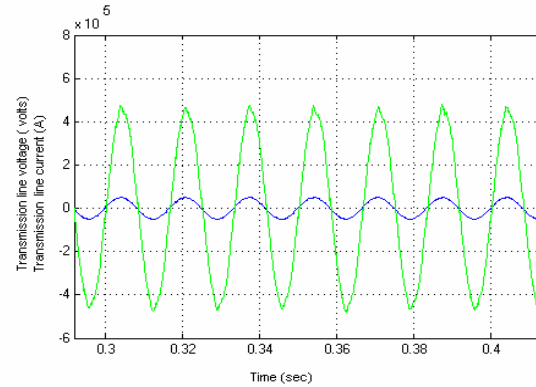

Fig. 18 Transmission line voltage and current for case (b)

The transmission line current and transmission line voltage of PI control for SSSC with SMES are shown in Fig. 18.

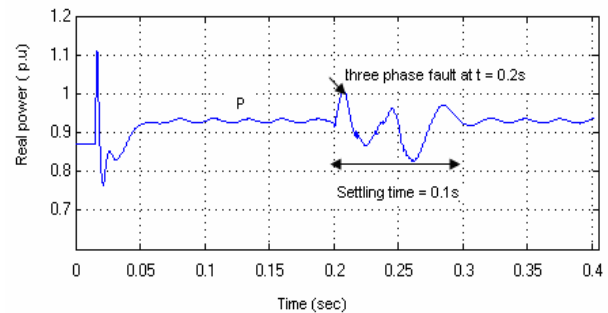

Fig. 19 Real power flow over the transmission line for a three-phase fault for case (a)

The transient stability is also analyzed when a three phase fault is applied at $t = 0.2$ s and cleared at $t = 0.3$ s with P_{ref} and Q_{ref} set to 0.93 p.u and 0.1 p.u respectively. Fig 19 and Fig. 20 show the real and reactive power flow over the transmission line for the three-phase fault for case (a).

Fig. 21 and Fig. 22 show the real and reactive power flow over the transmission line for the three-phase fault for case (b). The settling time for case (b) is very small (0.06 s and 0.08 s) compared to case (a) (0.1 s for both) in both the real and reactive power flows. This proves that the transient stability performance of the proposed PI control based SSSC with SMES is better compared to SSSC without SMES. Fig. 23 shows the voltage across SMES inductance.

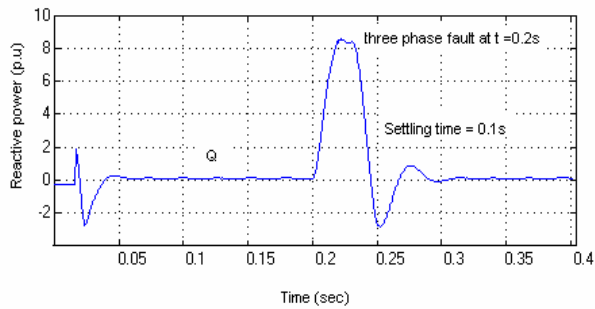

Fig. 20 Reactive power flow over the transmission line for a three-phase fault for case (a)

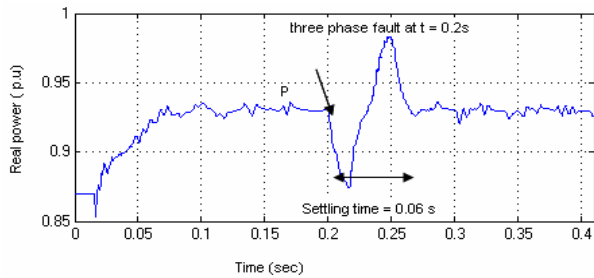

Fig. 21 Real power flow over the transmission line for a three-phase fault for case (b)

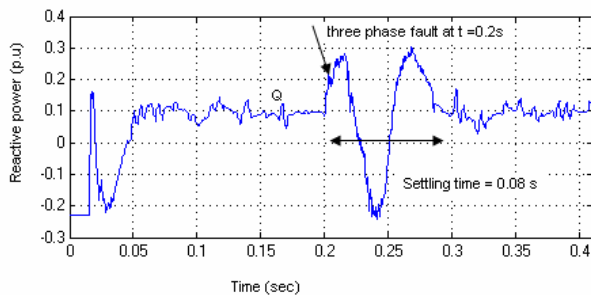

Fig. 22 Reactive power flow over the transmission line for a three-phase fault for case (b)

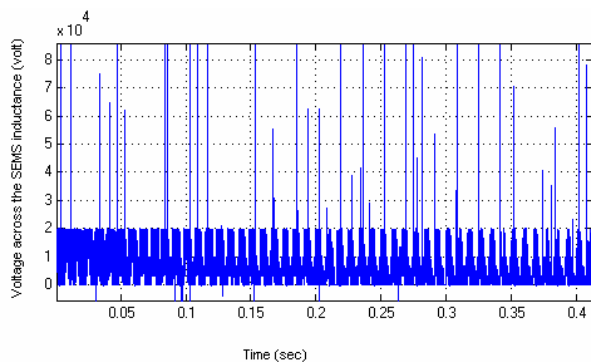

Fig. 23 Voltage across SMES inductance

V. CONCLUSIONS

The dynamic performance of PI control based SSSC with and without SMES power system are analyzed with Matlab/Simulink, assuming that the SSSC with and without SMES is connected to 500 kV transmission line of single machine infinite bus power system. The SSSC realized with 48 – pulse inverter generates symmetrical output voltages of desired magnitude and phase angle with very low harmonic

content. In this paper SMES is called as two quadrant chopper play an important role in new operating modes of power system. A PI control based SSSC with and without SMES has been developed to improve transient stability performance of the power system. It is inferred from the results that the PI control is a viable controller for the SSSC with and without SMES in order to maintain the real and reactive power flow over the transmission line to follow the set reference values under a variety of transient disturbances conditions.

ACKNOWLEDGMENT

We sincerely thank the Management, Secretary and Principal of Sona College of Technology, Salem for their complete support in doing this research work.

REFERENCES

- [1] Hingorani, N.G., "Role of FACTS in a Deregulated Market," *Proc. IEEE Power Engineering Society Winter Meeting*, Seattle, WA, USA, 2006, pp. 1-6.
- [2] IEEE Power Engineering Society Task Force: "FACTS Applications," *IEEE Publication*, 96TP116-0, (1996).
- [3] Song, Y.H. and A. T. Johns, "Flexible AC Transmission Systems," *IEE Press*, London, UK, (1999).
- [4] Molina, M.G. and P. E. Mercado, "Modeling of a Static Synchronous Compensator with Superconducting Magnetic Energy Storage for Applications on Frequency Control", *Proc. VIII SEPOPE*, Brasilia, Brazil, 2002, pp. 17-22.
- [5] Molina, M.G. and P. E. Mercado, "New Energy Storage Devices for Applications on Frequency Control of the Power System using FACTS Controllers," *Proc. X ERLAC*, Iguazú, Argentina, 14.6, 2003, 1-6.
- [6] Molina, M.G. and P. E. Mercado, "Evaluation of Energy Storage Systems for application in the Frequency Control", *Proc. 6th COBEP*, Florianópolis, Brazil, 2001, pp. 479-484.
- [7] M. S. El-Moursi and A. M. Sharaf, "Novel reactive power controllers for STATCOM and SSSC," *Electric Power Systems Research*, vol. 76, 2006, 06, pp. 228-241.
- [8] Lasseter R.H. and S. G. Lalali, "Power Conditioning Systems for Superconductive Magnetic Energy Storage," *IEEE Trans. on Energy Conversion*, 6, 3, 1991, pp. 381-387.
- [9] Anil. C. Pradhan and P.W. Lehn, "Frequency domain analysis of the static synchronous series compensator," *IEEE Transactions on Power Delivery*, vol. 21(1), January 2006, pp. 440-450.
- [10] B. Geethalakshmi and P. Dananjayan, "Investigations of Performance of UPFC without DC link capacitor," *Electric Power System Research*, vol. 78, Issue 4, pp. 736-746, April 2007.
- [11] V.S.C. Raviraj and P.C. Sen, "Comparative study of proportional-integral, sliding mode, and FLC for power converters," *IEEE Transactions on Industry Applications*, vol. 33 no. 2, March/April 1997, pp. 518-524.
- [12] Bruce S. Rigby and R. G. Harley, "An improved control scheme for a series capacitive reactance compensator based on a voltage-source inverter," *IEEE Trans. Industry Applications*, vol. 34, no. 2, Mar./Apr.1998, pp. 355-363.
- [13] Lasseter R.H. and S. G. Lalali, "Dynamic Response of Power Conditioning Systems for Superconductive Magnetic Energy Storage," *IEEE Trans. On Energy Conversion*, 6, 3, 1991, pp. 388-393.