

Stabilizing Voltage for Sheens with Motor Loading due to Starting Inductive Motor by using STATCOM

Mohammad Reza Askari, Mohsen Kazemi, and Ali Asghar Baziar

Abstract—In this treatise we will study the capability of static compensator for reactive power to stabilize sheen voltage with motor loading on power networks system. We also explain the structure and main function of STATCOM and the method to control it using STATCOM transformer current to simultaneously predict after telling about the necessity of FACTS tools to compensate in power networks. Then we study topology and controlling system to stabilize voltage during start of inductive motor. The outcome of stimulating by MATLAB software supports presented controlling idea and system in the treatise.

Keywords—Power network, inductive motor, reactive power, stability of voltage, STATCOM, FACTS

I. INTRODUCTION

RECENTLY, due to high consumption of electronic devices and also industrial development with continuous procedure, the necessity to have a supply with high quality has been heightened. Decreasing voltage of frequency may cause undesirable effects on the loading and it will lead to much damage and cost. Controlling reactive power is a basic step to maintain the quality of supply.

It is more necessary to prevent voltage turbulences which are the most common. On the other hand, it is required in standard limitation. As a result it is necessary to use proper reactive power compensator. A new technology called FACTS tools has been proposed in this condition that is in power network to enhance the reliability and quality of supply. In continuance of the treatise which is introducing a model of sample network, we firstly study the structure and STATCOM function, then it will be simulating inductive motor, and at the end, the results of simulating for sample network will be presented by MATLAB software. The results of simulating have shown that STATCOM can stabilize sheen voltage during starting inductive motor to prevent over drop (over decrease) on voltage during starting.

A. MohammadReza Askari is Department of Electrical Engineering, Sarvestan Branch, Islamic Azad University, Fars, Iran; email: Askari.MohammadReza@iausarv.ac.ir).

B. Mohsen Kazemi is Department of Electrical Engineering, Sarvestan Branch, Islamic Azad University, Fars, Iran; email: kazemi713@gmail.com).

C. AliAsghar Baziar is Department of Electrical Engineering, Sarvestan Branch, Islamic Azad University, Fars, Iran; email: aliasghar.baziar@yahoo.com).

II. INTRODUCTION THE SYSTEM

A. A model for the system of sample power

Fig. 1 shows a circuit of power network studied in this treatise. As it is obvious that an inductive motor has been connected through impedance (which represents torn impedance) to referential sheen.

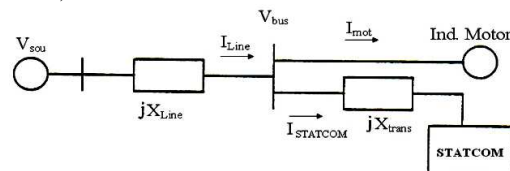

Fig. 1 A model for the system of sampling power

B. The structure of STATCOM

STATCOM in the view of connection to network can be used parallel.

This tool consists of three parts in general:

- Input transformer
- Inverter for voltage source
- DC capacitor as voltage source

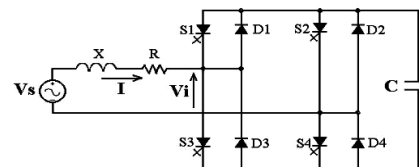

Fig. 2 A circular diagram of STATCOM single phase

A general diagram in shape (2) a STATCOM connected to the network. The inverter for source voltage includes for power electronic switches (which are turned off and on by compulsory commutation system) and four diodes which are inversely parallelized and a capacitor to provide DC voltage. Inverter is connected to the voltage source through a resistant and series inductance. The capacitor of inverter can charge through diodes and can be charged through switches. Assume that the capacitor has been fully (peak) charged, (if turning on and off is controlled in such a way that the inverter output and voltage source be at the same phase and altitude), there will be no current between inverter and current source. Therefore, it will not be exchanged (transferred) any power. But if we control switches in such a way that the inverter output to the source will have a post phase to the α degree angle, voltage

difference between output voltage inverter and voltage source can cause to flow circuit from source toward inverter. If resistant and series inductance between inverter and source are considered R, X in order, then current circuit will be delayed to the amount of $\gamma = \text{Arc tan} \frac{X}{R}$ from u vector.

C. STATCOM Controller

Having a proper controller for STATCOM depends on its function and for any function a particular controlling system must be considered. Controlling system used to stabilize voltage is composed of two parts. One of these is applied to determine measured variances form circuit power network of tree phase of STATCOM reference and the other part to produce the triennial circuit. The diagram of such controller is shown in figure (2).

In the structure of STATCOM, a type of inverter "VSI" has been used. Thus, in any of the common methods to control current of VSI inverter can be used to control the circuit of STATCOM transformer. These methods are divided into three categories:

- 1) Hysteresis control
- 2) PWM control
- 3) Controlling by predicting circuit of STATCOM transformer

The method used in this treatise is a controlling method by predicting circuit of STATCOM transformer. The diagram block of such controllers has been shown in figure (8).

The circuit controlling system inputs in general are three phase circuits of referential and read STATCOM transformer and if it is required an AC terminal voltage compensator the output of such controllers are signals to set the state (prostitution) of switches and the time to stay switches in a particular state.

It is obvious that the produced commands are in such way that the real circuits of STATCOM transformer approach its referential circuits.

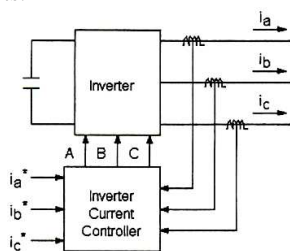

Fig. 3 diagram controlling by predicting circuit of STATCOM transformer

The main advantage of this method is fixed switching. In this method, in every switching circuit references of three phase inverter convert it into voltage references of three phases.

In other words, inverter output voltages are set in a way that circuit of 3 phase inverter approaches referential circuits. It is required to explain that performing such a method practically due to do mathematical calculation in each switching, we must have a microprocessor in controller unit. In this method

changes in compensator transformer real circuit are not set directly around the reference rate. But setting a switch frequency (sampling) can indirectly control maximum circuit error. It is obvious that more increase on switch frequency will decrease circuit error.

We write firstly differential equation on power system and inverter according to formula (1) and then we will take this formula interruptedly in a periodic limitation. Then the interrupted equation is set in a way that inverter real circuits follow the wave shape of current reference. In other words, they are used to convert 3 phase current references of inverter transformer or into output voltage 3 phase references of in vector. Next, the state of inverter switches to turn on and off are set in a way that inverter output voltage in each phase is similar as possible as referential voltages.

$$\begin{aligned} V_{ba}(t) - V_{an}(t) &= L \frac{di_a(t)}{dt} + Ri_a(t) \\ V_{bb}(t) - V_{bn}(t) &= L \frac{di_b(t)}{dt} + Ri_b(t) \\ V_{bc}(t) - V_{cn}(t) &= L \frac{di_c(t)}{dt} + Ri_c(t) \end{aligned} \tag{1}$$

On above formula (Vba,Vbb,Vbc) are network 3 phase voltage and (Van,Vbn,Vcn) are vector output voltage to 3 phase earthling system and (Ia , Ib , Ic) are connector transformer between STATCOM and power system. R and L are the said transformer Resistant and Inductance.

D. Stimulating Inductive Motor

The model used for stimulating inductive motor has been presented in reference books. There are different methods to stimulate computer inductive motor for equation formula. Common equation for stimulating symmetric inductive motor in the frame of desired reference is according to inductive field variance. Produced electric torque is obtained by inductive motor and shaft speed according to formula (2) and (3).

$$T_e = \psi_{ds} i_{qs} - \psi_{qs} i_{ds} \tag{2}$$

$$\omega_r = \frac{\omega_b}{2HP} (T_e - T_L) \tag{3}$$

To obtain stator currents of inductive motor, we will use formulae (4) and (5)

$$i_{qs} = \frac{1}{X_{IS}} (\psi_{qs} - \psi_{mq}) \tag{4}$$

$$i_{ds} = \frac{1}{X_{IS}} (\psi_{ds} - \psi_{md}) \tag{5}$$

Before we solve the above equation using formula (6), we would transformer voltages to a static frame and at the end stator current which are in a static frame, are converted into moment currents of 3 phase stator using formula (7)

$$\begin{bmatrix} V_q \\ V_d \\ V_0 \end{bmatrix} = \frac{2}{3} \begin{bmatrix} 1 & -1 & -1 \\ 0 & \frac{\sqrt{3}}{2} & -\frac{\sqrt{3}}{2} \\ \frac{1}{2} & \frac{1}{2} & \frac{1}{2} \end{bmatrix} \begin{bmatrix} V_a \\ V_b \\ V_c \end{bmatrix} \tag{6}$$

$$\begin{bmatrix} i_a \\ i_b \\ i_c \end{bmatrix} = \frac{2}{3} \begin{bmatrix} 1 & 0 & 1 \\ -\frac{1}{2} & -\frac{\sqrt{3}}{2} & 1 \\ -\frac{1}{2} & \frac{\sqrt{3}}{2} & 1 \end{bmatrix} \begin{bmatrix} i_q \\ i_d \\ 0 \end{bmatrix} \quad (7)$$

Used parameters in the above formula which are constant and the meaning and definition of variance and also rated properties of inductive motor is given in appendix (1).

If referential currents are calculated, diagram block to calculate sheen voltage is as follows Figure (1) shows bus voltage which is in a state without compensator; we use formula (8)

$$V_{Sou} - L_{Line} \frac{di_{Line}}{dt} = V_{bus} \quad (8)$$

We saw that in inductive motor stimulating, if we know the voltage of inductive motor, the circuit which is pulled by inductive motor determines the voltage of inductive motor.

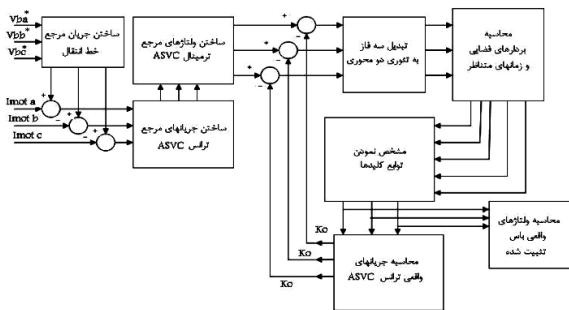

Fig. 4 Diagram block

The circuit of Iline in formula (5) is motor circuit (Imot) therefore; we have 2 equations two unknowns get gain inductive motor circuit and sheen voltage (the equations 1 to 7 and equation 8 are written separately for each phase).

We use a parallel STATCOM to stabilize the bus voltage. The STATCOM is connected parallel to the appointed bus. By knowing the referential circuit of STATCOM transformer we act as follows:

Assume that V_{sou} is a constant and its value is a per unit. Bus referential voltage is considered a per unit.

$$P_{transfer} = \frac{V_{sou} \times V_{bus}}{X_{Line}} \sin(\delta) \quad (9)$$

It's obvious the power transfers through phase difference between V_{sou} and V_{bus} in attention to rated value of inductive motor and formula (9), V_{sou} is bus tunon voltage and V_{bus} is sheen voltage that inductive motor is connected to it and X line value is known and the single unknown of equation is sin(δ) or δ. The circuit value pulled by inductive motor from network is calculated by knowing V_{bus}. Note that used voltage to solve differential equation on inductive motor must be real. Specifying referential circuit of transfer line obtained by formula 10 and inductive motor circuit gotten by solving differential equations of inductive motor and using formula 11 the value of referential circuit of STATCOM transformer is calculated:

$$V_{Sou} - V_{bus(ref)} = L \frac{di_{Line(ref)}}{dt} \quad (10)$$

$$I_{STATCOM(ref)} = I_{Line(ref)} - I_{mot} \quad (11)$$

Knowing referential currents of STATCOM transformer and solving equation (12) gets from referential voltage related to 3 phase compensator AC terminal.

$$V_{STATCOM} = V_{bus(ref)} - L_{STATCOM} \frac{di_{STATCOM(ref)}}{dt} \quad (12)$$

After operating switching command to keys and determining real voltage of compensator AC terminal, stated in chapter 3, the real circuits of STATCOM transformer is calculated by formula 13.

$$V_{bus(ref)} - V_{STATCOM(real)} = L_{STATCOM} \frac{di_{STATCOM(real)}}{dt} \quad (13)$$

Note that V_{bus(real)} is not calculated in this step and we use V_{bus(real)} in the previous step.

After calculating real current of STATCOM transformer by using formula 14 the real current value of transformer line and real value of sheen voltage is calculated.

$$I_{Line(real)} = I_{STATCOM(real)} + I_{mot} \quad (14)$$

$$V_{bus(real)} = V_{sou} - L_{Line} \frac{di_{Line(real)}}{dt}$$

III. STIMULATING RESULTS

Stimulating related to effective voltages and inductive motor speed have been presented in figures (8) and (9) in a state without using compensator. Figure (8) shows that voltage has been decreased more than standard value in start. We know that during start of an inductive motor a great circuit is pulled (about seven times of rated value). Having an inductive motor with greater power will increase starting time. When a great circuit is get from network decreased voltage impedance Iline will increase and if tunon voltage be constant (fixed), sheen voltage connected to it will decrease. Considering IEEE-519 standard change in voltage sheen shouldn't exceed ±5 percent of rated value.

Starting such inductive motor is one of the most common used on power network (system) and industry every day.

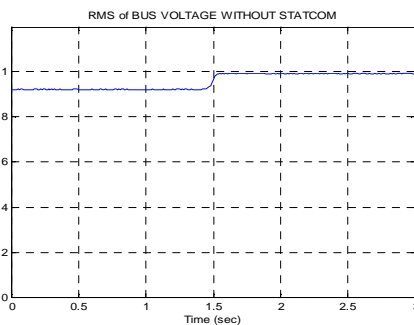

Fig. 5 Sheen efficient voltage when it began to start inductive motor to get stable (permanent) state (before starting sheen voltage is a p.u.)

Stimulating shows that V_{bus} effective at starting inductive motor with 2250 horse power and 2300 volt is about 0.92 this value exceeds from the standard limitation. In note to great

decreasing in bus voltage when starting inductive motor the results of stimulating for sampling network is done by static compensator of reactive power.

In M-File program the written file for stimulating at first differential equations for inductive motor is calculated with compensator circuit pulled by motor.

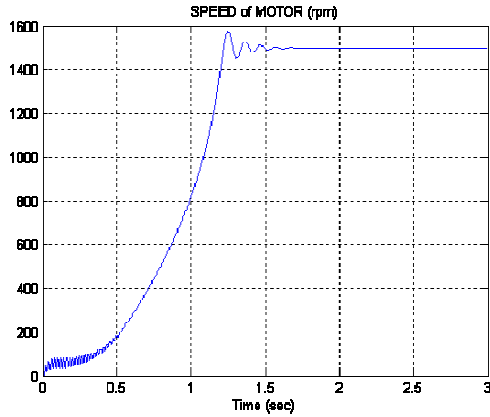

Fig. 6 Speed of inductive motor

Speed of inductive motor when it begins to start inductive motor to get stable condition to calculate the value of referential circuit for transformer line we use from 10 formula and to calculate referential circuit of STATCOM transformer we use from 11 formula. Figure (7) shows the shape (diagram) circuit waves of inductive motor and referential circuit of transformer line and STATCOM transformer.

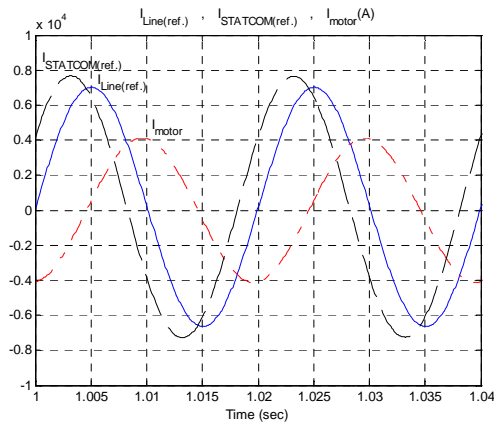

Fig. 7 The shape of circuit wave related to phase inductive motor and referential circuits of transformer line and STATCOM transformer

The shape of circuit wave related to phase inductive motor and referential circuits of transformer line and STATCOM transformer using formula (14) the real current of transformer line is got which that is our final air to stabilize sheen voltage in starting inductive motor.

In figure (8) referential and real circuit waves of a phase STATCOM transformer and in shape 8 referential and real circuit waves of a phase transformer line have been shown. In shape (9) a real voltage and referential phase a related to the sheen has been shown.

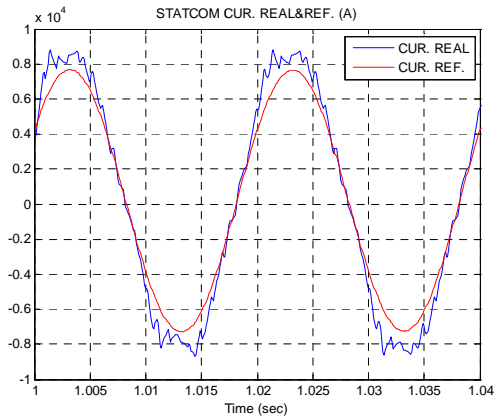

Fig. 8 Real and referential circuits related to STATCOM transformer phase a

In Fig. 1 the shape of real voltage wave related to inverter output phase A with a shape of referential voltage wave related to inverter phase a. we see that the first harmony of made voltages is referential voltage but due to switching we will have other harmonics.

Fig. 11 shows a sheen effective voltage phase when it begin to start inductive motor.

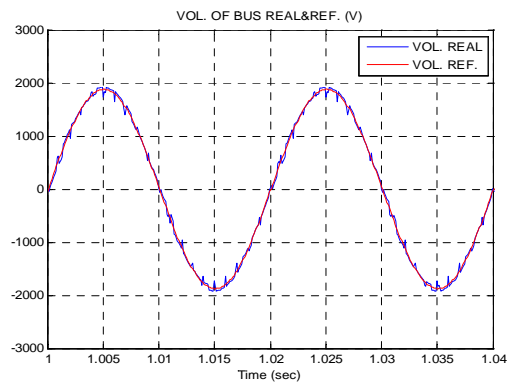

Fig. 9 Bus real and referential voltage related to phase A

Note that the cost of stabilizing voltage, injected harmonic voltage, and the current to stabilized bus according to IEC, IEEE standard.

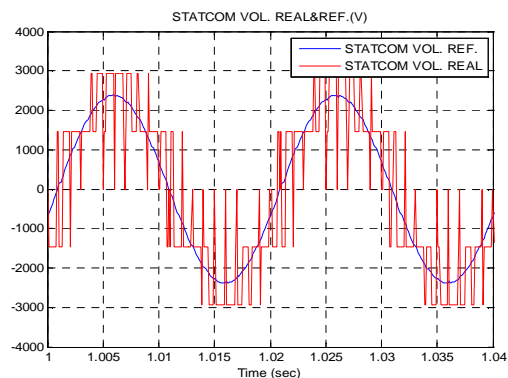

Fig. 10 The shape of wave related to real and referential voltage for output inverter of phase A

The injected harmonics to the power network should be in a patricidal limitation. In standards for industrial loading must be at the altitude of 2.3 kv to 63 kv.

Value of THD should not exceed 5 percent.

Harmonics of voltage which produces STATCOM have been shown in shape 12 in perunit on the major harmonic altitude. You saw that none of harmonics are out of standard permission limitation.

The value of main harmonic altitude on bus rated voltage is 1.003

The calculated value for THD in this state is 3.3

Therefore STATCOM can stabilize voltage by considering standard.

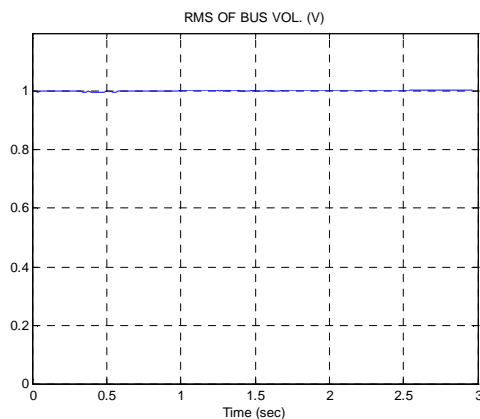

Fig. 11 Stabilized bus effective voltage related to phase A

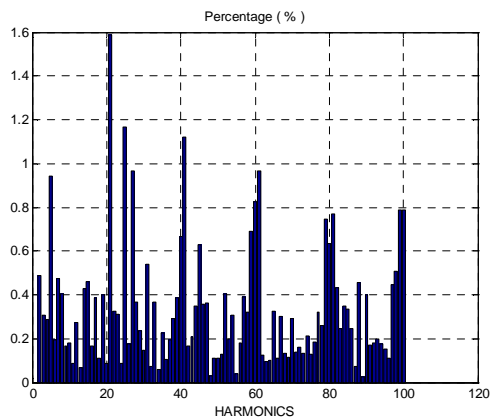

Fig. 12 Produced harmonics by STATCOM without harmony and based on the first harmonic

IV. CONCLUSION

In this treatise we studied two type of common error on power network, attempting to decline terrible effects of such error (fault) by using STATCOM as FACTS tools. There is a variety of faults in power network and FACTS tools are extended everyday and now there is a variety of FACTS type explaining chapter one and as we stated that by changing control method and switching we can use for different objects.

STATCOM in comparison to common compensator or SVC has advantages that caused to be more absorbed in new technology. There are some examples of such advantages as

follow;

1. STATCOM has a small capacitor in comparison to SVC and can act as a producer and as absorbent of reactive power while SVC, capacitors and reactors take a large space (room) in cities using STATCOM will be very useful (desirable) in distribution system because space is an important parameter.
2. STATCOM by giving a faster response in comparison to common SVC's can guarantee stability of system of course note that from different types of SVC's now is used in power system those that don't have any control, it will cost 3 or four dollars for every KVAR. And SVC's which have control will cost about 7 to 8 dollars for each KVAR. How days ASVC which is a scientific term called STATCOM is a new technology that its installation will cost for the first time is too great (about 40 dollars for each KVAR). But it's much less. They also have more function in comparison to SVC s.

REFERENCES

- [1] Paul C.Krause "Analysis of Electric Machinery" , Pub. By Mc Graw-hill book Company, 1986, TK 2181 k.72.
- [2] A.Tahri , F. Tahri , A. AlRadadi , A. Draou , "Analysis and control of advanced static VAR compensator based on the theory of the instantaneous reactive power" , Electrical Machines and Power Electronics, 2007. ACEMP '07. International Aegean Conference on , pp. 840-845 , 10-12 Sept. 2007
- [3] H. Akagi , H. Fujita , "A New Power Line Conditioner for Harmonic Compensation in Power System" , IEEE Trans. , Power Delivery , vol. 10 , no. 3 , pp. 1570-1575 , July 2002.
- [4] M. Abazari, S. Mahdavi, J. Ehsan, M. Zolghadri, "Transient stability improvement by using advanced static VAR compensator" , Power Tech Conference Proceedings, 2003 IEEE Bologna , vol. 2 , pp. 7-12 , 23-26 June 2003
- [5] C.W. Edwards, K.E. Mattern, E.J. Stacey, P.R.Nannery and J.Gubernick, "Advanced Static Var generator employing GTO thyristors," IEEE Transaction on power Delivery, vol.3, no.4, pp. 1622-1627, Oct.1988
- [6] C.Schauder and H.Mehta. "Vector analysis and control of Advanced Static Var Compensator" , IEE Proceedings-C, vol.140 no.4, pp.299-3