

Finite Element Prediction on the Machining Stability of Milling Machine with Experimental Verification

Jui P. Hung*, Yuan L. Lai, Hui, T. You

Abstract—Chatter vibration has been a troublesome problem for a machine tool toward the high precision and high speed machining. Essentially, the machining performance is determined by the dynamic characteristics of the machine tool structure and dynamics of cutting process, which can further be identified in terms of the stability lobe diagram. Therefore, realization on the machine tool dynamic behavior can help to enhance the cutting stability. To assess the dynamic characteristics and machining stability of a vertical milling system under the influence of a linear guide, this study developed a finite element model integrated the modeling of linear components with the implementation of contact stiffness at the rolling interface. Both the finite element simulations and experimental measurements reveal that the linear guide with different preload greatly affects the vibration behavior and milling stability of the vertical column spindle head system, which also clearly indicate that the predictions of the machining stability agree well with the cutting tests. It is believed that the proposed model can be successfully applied to evaluate the dynamics performance of machine tool systems of various configurations.

Keywords—Machining stability, Vertical milling machine, Linear guide, Contact stiffness.

I. INTRODUCTION

WITH the demand of high speed and high precision machining, machine tools are being designed and manufactured with high dynamic performance in positioning accuracy and cutting stability. However, chatter vibration induced by self excitation during chip generation process has been a fatal problem for a machine tool in machining operation. As a well recognized fact, the structure dynamic characteristic of a machine tool plays an important role in determining the machining performance. It is therefore of importance to realize the dynamic characteristics of a machine tool at the design stage.

On the other hand, currently, the machine tool structures are designed with the modularity concept for satisfying the multipurpose or specific industrial applications. A CNC vertical milling machine was constructed with five main

modules, including the machine base, saddle, table, vertical column, and headstock with a spindle tool unit. With the modular design concept, an innovative CNC machine tool can be fabricated by assembling these modularized components by using feeding mechanisms of various structural configurations [1,2]. Before fabricating a prototype for performance identification, the designer should evaluate whether all the design requirements are satisfied in order to achieve the required performance. For this purpose, the finite element approach has been widely used to assess the static and dynamic behavior of machine tool structures because of the efficiency and reliability that it offers in the task of analysis. However, the dynamics of a machine tool cannot be easily formulated as a composition of individual module because there are various interfaces at connection joints such as bolted components. Such connection joints cannot be treated as a rigid interface; on the contrary, they form weak links between components and greatly affect the overall stiffness and mechanical characteristics of the assembled structure [3]. As a consequence, the modeling of an interface and the identification of the interfacial characteristics is of importance in the dynamic analysis of a machine tool structure [4]. With intense nonlinearity, the interface characteristics at joints could not be directly obtained using an analysis method unless experimental measurements were also made [5–7].

Recently, linear rolling guides have been widely used in high-precision positioning systems because of their superiority over conventional bearings with linear sliding motion. In practice, an oversized rolling ball is usually employed to produce adequate preload in order to increase the structural rigidity and the load-carrying ability of a rolling guide. Research studies [9–11] have shown that a rolling guide exhibits different vibration characteristics depending on the change in the contact stiffness at the ball grooves when the preload is set to different magnitudes. Hung [12] also verified that the external load applied to the positioning stage caused variations in both the contact force and the contact stiffness of rolling guides and hence caused the stage to vibrate at different frequencies. As proved in the above studies, the stiffness of the interfaces between combined components dominates the overall stiffness of a machine tool structure, apart from the structural stiffness of the main modularized parts. Therefore, it is important to pay more attention to evaluate the effect of rolling interfaces on the machining stability of a machine tool.

*Jui P. Hung is with the Department of Mechanical Engineering, National Chin-Yi University of Technology, Taichung, Taiwan, R.O.C. (phone: +886-4-23924505; fax: 886-4-23939932, e-mail: hungjp@ncut.edu.tw)

Yuan L. Lai, is with the Department of Mechanical and Automation Engineering, Dayeh University, Changhua, Taiwan, R.O.C.

Hui T. You is with the Department of Mechanical Engineering, National Chin-Yi University of Technology, Taichung, Taiwan, R.O.C.

This study was aimed at investigating the machining stability of a vertical milling machine under the influence of linear guide with different preload. For this purpose, a finite element model of the column spindle system was constructed with the integration of the modeling of linear rolling components. The dynamic behavior and cutting stability of the milling machine were predicted. Furthermore, the simulation results were validated with the experimental measurements performed on a prototype machine.

II. CONSTRUCTION OF VERTICAL MILLING MACHINE

In order to examine the machining characteristics, a simplified vertical milling machine with small-scaled dimensions was designed and fabricated, as shown in Fig. 1. The vertical column was constructed using carbon steel plates. Two guide rails were secured on the front plate of the column at a span of 160 mm. The sliding carriage of the spindle head was mounted on the column with pairs of linear guides and driven with a ball screw. The commercial linear guides (HG series) have four ball grooves with a circular arc profile, forming a point contact at an angle of 45° [13]. In addition, for enhancing their rigidity, the linear guides can be preloaded to different levels by setting oversized steel balls within the ball groove, and they are generally quantified as light preload (Z0, 0.01C) and heavy preload (ZB, 0.11C), where C denotes the dynamic load rating (11.38kN). The driven ball screw has a diameter of 14 mm, a lead pitch of 4 mm, and a basic dynamic load rating C of 4.07 kN and is slightly preloaded to a level of 0.06C so as to lessen the axial backlash [14]. Further, in order to ensure rigidity balance with the ball screw, the standardized ball screw support units coded EK12 and EF10 were used at both ends of the screw shaft [15]. In addition, a high-frequency spindle unit, having a weight of 4.1 kg and a maximum speed of 36000 rpm, was installed on the sliding carriage. Fig.1 also shows the global coordinate system used in the machine model, where the X and Y axes are defined as the two horizontal axes pointing toward right and, respectively, and the Z axis is the vertical one along the column direction. In addition, a local coordinate system was defined at the spindle head for describing the vibration mode.

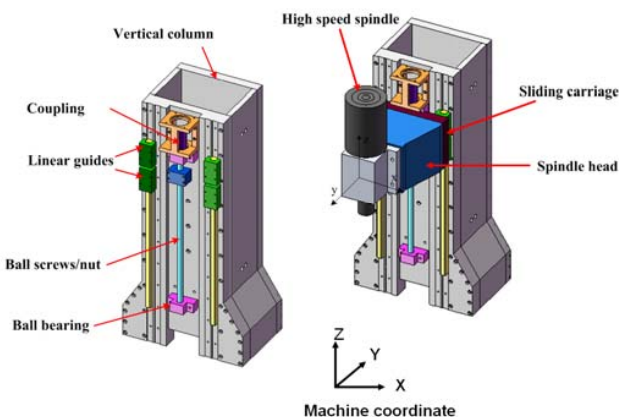

Fig. 1 Construction of vertical milling machine.

III. FINITE ELEMENT MODELING

The key point for accurate modeling a machine tool structure is the simulation of the rolling elements within ball grooves of the linear components. The rolling interface greatly determines whether the simulation results can approach the real characteristics of the system in an effective way [12]. Therefore, it was adequately simplified and introduced into the finite element model of the vertical milling machine.

A. Modeling of the rolling interface

As shown in Fig. 2(a), the linear guide was designed with two or four rows of rolling balls, where the ball groove had the contact profile of a circular arc, forming a two-point contact mode [16]. The ball screw was designed with a Gothic groove, forming a four-point contact mode. In general, the contact force between a rolling ball and the raceway can be related to the local deformation at the contact point by the Hertzian expression [17]

$$Q = K_h \alpha^{3/2}, \quad (1)$$

where Q denotes the contact force and α is the elastic deformation at the contact point. K_h represents the Hertz constant, which is determined by the contact geometry and material properties of the linear components. Details can be available in literatures [18, 19]. The normal stiffness at a specific preload can then be obtained as

$$K_n = \frac{dQ}{d\alpha} = \frac{3}{2} K_h \alpha^{1/2} = \frac{3}{2} K_h^{2/3} Q^{1/3}. \quad (2)$$

As revealed in Eq. (2), the contact stiffness in the normal direction depends nonlinearly on the contact force, which is essentially determined by the initial preload set on the rolling balls.

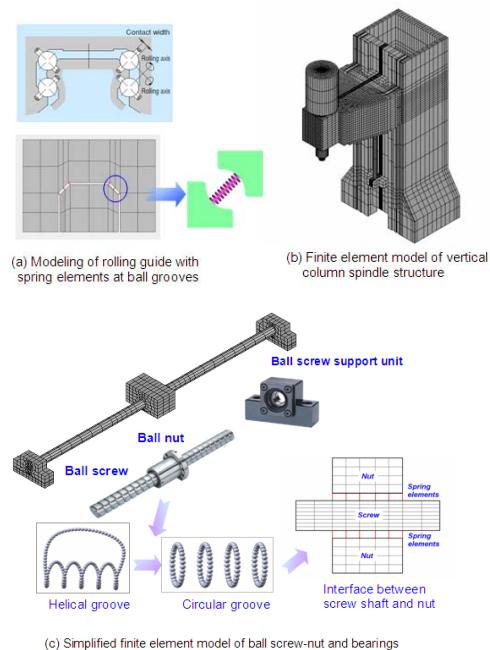

Fig. 2 Finite element modeling of vertical column spindle system.

B. Creation of finite element model

Fig. 2 presents the finite element model of the vertical column spindle structure including a motorized spindle tool. Each structural component of the system was meshed with eight-node brick elements, with a total of 38121 elements and 46597 nodes, after a convergence test. The components of the feeding mechanism, such as a ball bearing, ball screw and ball nut, and linear guides were included in the model. For the model to be realistic, the main bodies of the linear components were modeled as solid elements and connected with spring elements at the rolling interfaces. For a rolling guide, it has four ball grooves with circular profiles, forming a two-point contact state between the rolling ball and the groove. In order to avoid the complexity in mesh generation of the rolling grooves in the finite element model, the four rolling grooves were simplified as two grooves, as shown in Fig. 2(b). The sliding block and guide rail were directly connected using a series of spring elements by intentionally ignoring the effect of the rolling balls, but the spring elements at each ball groove had an overall contact stiffness equivalent to that of the original guide model. This two-point contact mode could greatly increase the efficiency of preparing the analysis model, without affecting the accuracy of the results. On the basis of the specifications of the rolling guides (ball diameter $d=3.175\text{mm}$, diameter of circular groove $D=3.297\text{mm}$, dynamic loading capacity $C=11380\text{N}$), the contact stiffness K_n was calculated as $9.76\text{N}/\mu\text{m}$ for low preload and $21.7\text{N}/\mu\text{m}$ for high preload.

The ball screw and ball bearing were also modeled in a similar manner. The ball screw was modeled as a cylindrical shaft and meshed with 3D solid elements, rather than flexible beam elements [20]. The overall stiffness in the radial and axial directions could be directly determined according to the dimensions of the screw spindle and ball nut. In addition, considering the complexity and inconvenience in meshing the helical groove around the screw shaft, the contact between the screw and the nut was simplified as a circular contact mode, as shown in Fig. 2 (c). With this simplified mode, the rolling

interface at the ball groove was simulated with elastic spring elements connecting the ball nut and the screw shaft. According to the specifications of the ball screw, the associated contact stiffness at the screw groove was estimated as $152\text{N}/\mu\text{m}$, which is slightly less than that of the ball nut (approximately $168\text{N}/\mu\text{m}$) obtained from technical information [14]. For a bearing, the inner and outer rings were also connected by spring elements distributed around the ring raceway, which provided the stiffness in both axial and radial directions to sustain the ball screw. The bearing stiffness for the angular contact bearing was obtained from the bearing manufacturer, which was reported as $88\text{N}/\mu\text{m}$ [15].

Regarding the motorized spindle unit, since it consists of driven motor, the spindle shaft and bearing assemblies, the spindle dynamics are more complicated than any other single linear component and have been another important issue in machine tool design, but not included in the current study. For simplification, the spindle unit was modeled into a cylindrical body of various sections, but with an equivalent weight of the original spindle unit.

C. Model validation with vibration test

To validate the finite element model, we first performed modal analysis to obtain the fundamental vibration characteristics of the vertical column spindle head. According to the finite element simulation [21], the vibration motions associated with the vertical column spindle head are critical modes that affect the spindle to show a lower dynamic stiffness, which are illustrated in Fig. 3 (a) as the modes of pitching and yawing vibration of the spindle head, respectively. Therefore, in this study the tool point frequency response function of the two modes were predicted for obtaining the stability lobes. For finite element harmonic analysis, the materials used for all components were carbon steel with an elastic modulus $E = 200\text{GPa}$, Poisson's ratio $\mu = 0.3$, and density $\rho = 7800\text{Kg}/\text{m}^3$.

As predicted by modal analysis, the vibration frequencies associated with the first, second pitching motions and yawing motion of the spindle head equipped with low preloaded (Z0)

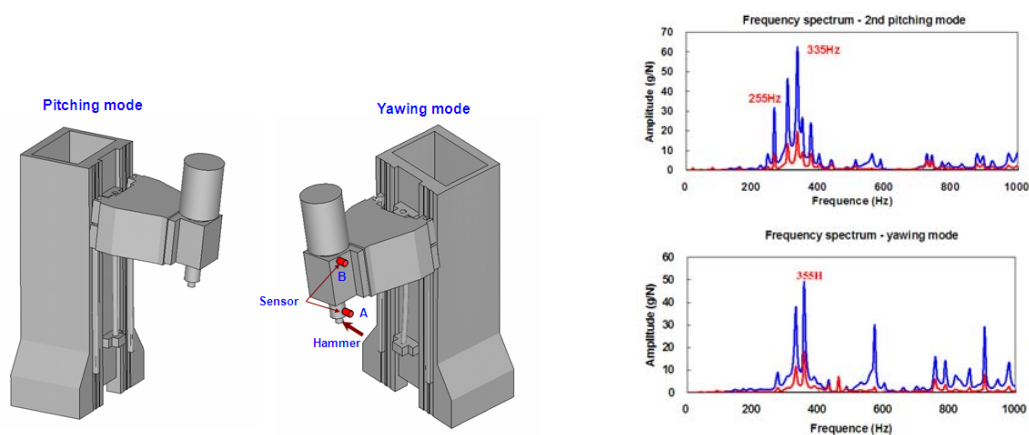

Fig. 3 (a) Vibration modes associated with the spindle head, and (b) frequency spectrums measured in vibration test.

linear guide modulus are 262, 332, and 352Hz respectively. For spindle head with high preloaded (ZB) linear guides, the corresponding natural frequencies are 310, 407 and 483 Hz, respectively. It is noted that linear guide preload has a great influence on the vibration frequency of spindle head, with differences approximately of 18~37%, when the preloaded was adjusted from Z0 to ZB. The result of modal analysis was also verified by means of vibration test conducted on the milling machine prototype. The vibration testing configuration was presented in Fig. 3(a), in which the accelerometer was mounted on the spindle tail to measure the vibration signal responding to the impact by hammer that was applied on the other side. With this manner, the yawing mode of the spindle head about the X-axis in the local coordinate system can be measured. Fig. 3(b) depict the frequency spectrums corresponding to the yawing and pitching vibrations of the spindle head that was mounted on the sliding head with low preloaded linear guides. The natural frequencies corresponding to the first, second pitching motions and yawing vibrations were measured as 255, 335 and 355Hz, respectively, which agree well with the finite element modal analysis, as listed in Table 1 and 2. Comparisons of the vibration measurements and finite element predictions clear identified the accuracy of the modeling of the vertical spindle column structure, in which the modeling of the rolling interfaces exiting within the various linear components played an important role.

The damping ratio required for harmonic analysis was further calculated according to the Half-power method. Table 2 presents the damping ratios of the vertical column spindle structure in X and Y directions. It is found that the damping characteristics are also affected by the preload of the linear guides. A vertical spindle head system installed with high preloaded guide modulus behaves a lower damping characteristic as compared to that with low preloaded guides. The harmonic analysis was then performed with the validated finite element model, so as to examine the dynamic response of the spindle head when it was subjected to a simulated cutting at the spindle tail in frequency ranges of 200~1200Hz.

D. Prediction of tool point frequency response

Fig.4 illustrates the frequency response of the spindle tip in the X and Y directions, respectively, which also demonstrate the influence of the preload amount of linear guide modulus. From Fig.4, the lowest dynamic stiffness in X direction was calculated as 0.352 and 0.903 N/ μ m for low and high preloaded spindle head, respectively. In addition, the minimum dynamic stiffness is found to occur at frequency of the yawing vibration of spindle head. A similar frequency response also is found in the Y direction (Fig. 4). It can be seen that the adjustment of the linear guide preload from low to high leads to an increase in the minimum dynamic stiffness from 1.17 to 2.41 N/ μ m. As noticed in the figure, the frequency inducing the minimum stiffness is equivalent to the pitching frequency, which is associated with the vibration of the spindle head. The results obtained from the harmonic analysis again verify that the yawing and pitching modes indeed dominate the vibration of

TABLE I FINITE ELEMENT PREDICTED NATURAL FREQUENCIES OF SPINDLE HEAD

Vibration mode	Finite element predicted natural frequency (Hz)	
	Low preload (Z0)	High preload (ZB)
Pitching vibration of spindle head, accompanied with bending vibration of vertical column	262	310
Pitching vibration of spindle head	332	407
Yawing vibration of spindle head	352	483

TABLE II EXPERIMENTAL MEASURED VIBRATION FREQUENCIES AND DAMPING RATIO OF FUNDAMENTAL MODES OF SPINDLE HEAD

Vibration mode	Low preload (Z0)		High preload (ZB)	
	Natural frequency, (Hz)	Damping ratio, ξ	Natural frequency, (Hz)	Damping ratio, ξ
Pitching vibration of spindle head, accompanied with bending vibration of vertical column	255	0.009	310	0.006
Pitching vibration of spindle head	335	0.013	390	0.008
Yawing vibration of spindle head	355	0.008	465	0.005

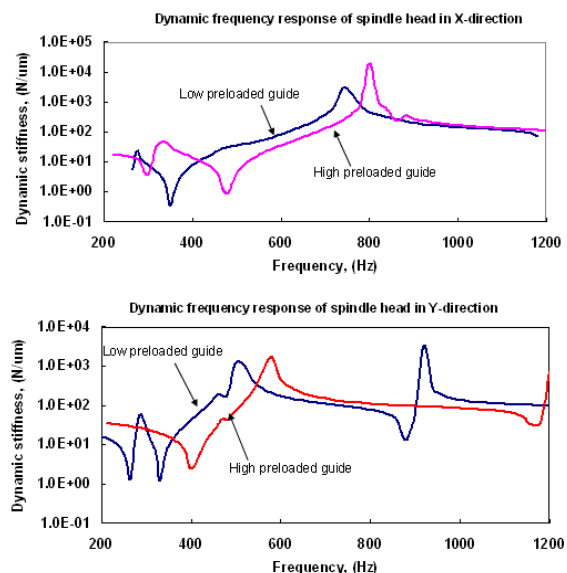

Fig. 4 The frequency response of the spindle tip in the X and Y directions, respectively.

spindle head during machining operation. When the yawing or pitching mode is excited during machining, the spindle head will behave more compliantly than at another frequency; this consequently causes the spindle tool to deform greatly or vibrate unstably and thereby degrades the machining performance.

From this analysis, we can again identify that a linear guide could be a major component that affects the dynamic characteristics of the entire vertical column spindle structure.

IV. PREDICTION OF STABILITY AND EXPERIMENTAL VERIFICATION

A. Stability model and predicted lobe diagram

The machining stability of the vertical milling machine can be predicted based on the Alintas and Budak's approach [22], in which the time varying force coefficient of dynamic milling process model was approximated by their Fourier series components, which results in a the stability relationship between the chatter free axial depths of cutting Z_{min} and spindle speeds n in end mill operation, as developed by Gagnol et al in the followings [23].

The speed-dependent transfer function at the tool tip can be expressed as

$$H(jw) = \frac{X(jw)}{F(jw)} = R_e(w) + jI_m(w) \quad (3)$$

$$Z_{min} = \frac{-1}{NK_t K_r R_e(w)} \quad (4)$$

$$\varphi = \pi - 2 \tan^{-1} \frac{I_m(w)}{R_e(w)} \quad (5)$$

$$n = \frac{60\omega_c}{N(2k\pi + \varphi)}, \quad k = lobes(0,1,2,...) \quad (6)$$

In above equations, $H(jw)=R_e(w)+jI_m(w)$, R_e and I_m are, respectively, the real and imaginary part of the transfer function of the tool tip that subject to the dynamic cutting force. K_t and K_r are the cutting resistance coefficients in the tangential and radial direction to the cutter. N is the number of the cutter teeth. k is the lobe number.

In this prediction, a two-tooth carbide cutter was employed as the tool to machine the stock material of Al7075. The cutting coefficients were calibrated as $K_t=796 \text{ N/mm}^2$ and $K_r=0.21$ [24]. The stability lobes diagram was obtained by integrating the finite element predicted tool tip frequency response function into the chatter stability approaches. Fig. 5 illustrates the stability diagram of the vertical milling machine, which compares the effect of preload of linear guide modulus supporting the spindle head in feeding mechanism. It is noted that when the spindle head was equipped with high preloaded guides, the limiting axial depth with free chattering is about 2.9 mm for spindle speed ranging from 4000 to 8000rpm, but for the spindle head with lower preloaded guides, the minimum axial depth with free chatter is approximately 1.6 mm under the same spindle speed. Again, the results of stability

analysis verify that the linear guide plays an important role in affecting the machining performance vertical milling machine.

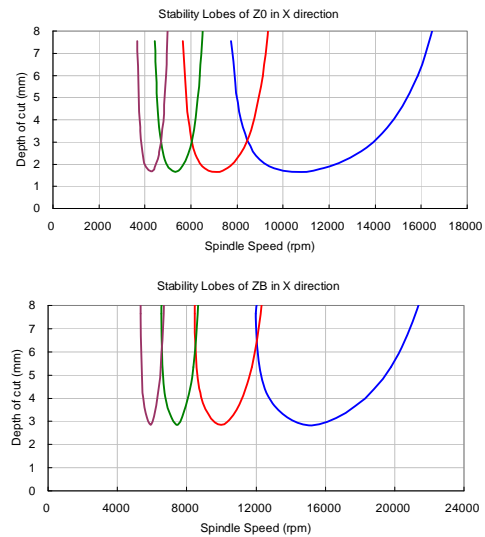

Fig. 5 Stability lobes diagram of the vertical milling machine which was equipped with low and high preloaded linear guide modulus, respectively.

B. Experimental verification - machining test

As shown in Fig. 6, the machining tests were configured on the prototype of the vertical milling machine in which the low preloaded guide modulus was installed at the sliding carriage of spindle head. A Tungsten carbide cutter (two-tooth with a diameter of 5mm and length of 50 mm) was employed as the tool to machine the stock material of Al7075. Full immersion slots were milled at varying axial depth and spindle speed in the X-direction at the feeding rate of 75mm/min. In order to identify stable and unstable cutting, the sound signal emitted in cutting and vibration signal of spindle head were

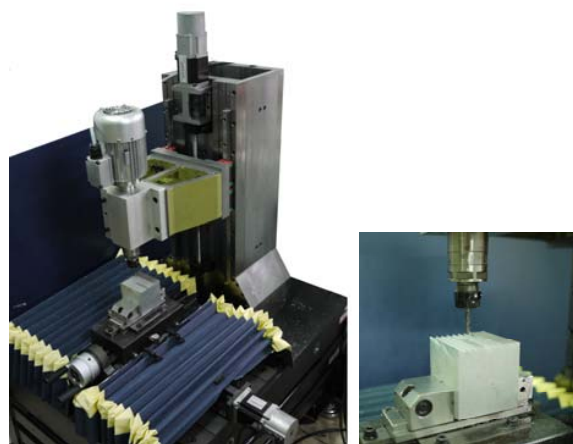

Fig. 6 Configuration of machining tests on the vertical milling machine.

recorded using a unidirectional microphone and accelerometer during the machining process.

Beside, for a reliable reference without chatter, an initial free chattering cutting depth was chosen for every specified spindle speed according to the predicted stability lobe diagram.

The experimental results are compared with the predicted stability lobes, as shown in Fig. 7. In the figure, each cutting with chatter or no chatter is located on the diagram with solid circle or open circle, respectively. For example, for a cutting of axial depth of 2mm, chattering was detected under respectively spindle speeds of 4000 or 5400 or 7376 rpm, but no chatter occurred when the spindle speed was raised to 8000rpm. At spindle speed of 4000rpm, unstable cutting was observed when cutting depth was set at 2mm, but no chatter occurred when the cutting depth was adjusted to 1 mm. The identification of the chatter was observed and verified from the vibration spectrum presented in Fig. 8. It is obvious that under the same cutting depth, the vibration amplitude induced at spindle speed of 4000 rpm appeared to be greater than that induced at speed of 8000rpm. These phenomena again address fact that the influence of the spindle speed on the surface quality can be expected from the stability lobe diagram.

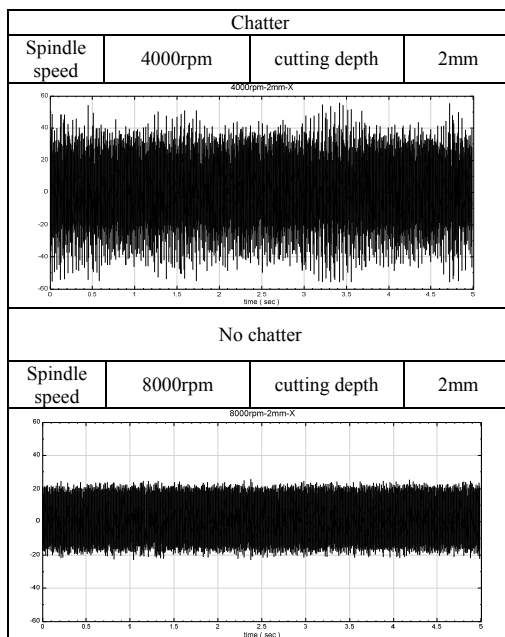

Fig. 8 Vibration spectrums measured in machining tests.

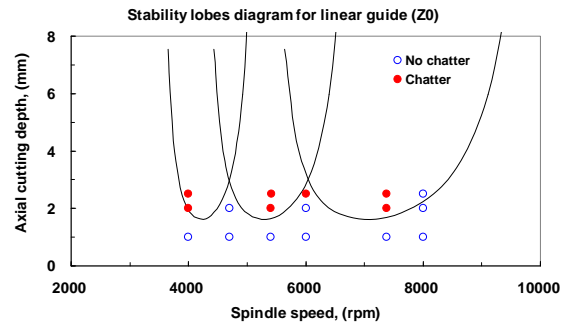

Fig. 7 Predicted stability lobe compared with experimental cutting tests.

V. CONCLUSIONS

This study was aimed to investigate the machining stability of a vertical milling machine through finite element prediction and machining tests. The influence of the preload of a linear rolling guide on the machining performance was also analyzed. As was expected, current results demonstrate that the linear guide preload dominates the vibration behavior associated with a spindle head, and hence greatly affect the cutting parameters to be at chatter or free chatter machining stability. A high preloaded guide modulus installed in the spindle feeding mechanism can effectively enhance the machining performance. As a conclusion, this study has verified that the proposed finite element model can be used to quantify the dynamics characteristics and machining stability of machine tool systems of various configurations.

ACKNOWLEDGMENT

The work was supported by National Science Council in Taiwan through project number NSC99-2221-E-167-003, which is gratefully acknowledged.

REFERENCES

- [1] Yoshimi Ito, Modular design for machine tool, *McGraw Hill Company*, 2008.
- [2] Y. Seo, D. P. Hong, I. Kim, T. Kim, D. Sheen, G. B. Lee, Structure modeling of machine tools and internet-based implementation, *Proceedings of the 2005 Winter Simulation Conference*, December 2005, Orlando, Florida, USA.
- [3] C. F. Beards, Damping in structural joints, *The Shock and Vibration Digest*, 24(7) (1992) 3- 7.
- [4] M. Yoshihara, Computer-aided design improvement of machine tool states Incorporating joint dynamics data, *Annals of the CIRP*. 28(1) (1979) 241-246.
- [5] Y.M. Huang, W.P. Fu, L.X. Dong, Research on the normal dynamic characteristic parameters of joint surface, *Journal of Mechanical Engineering* 29 (3) (1993) 74-77.
- [6] Y. Lin, W. Chen, A method of identifying interface characteristic for machine tools design, *Journal of Sound and Vibration* 255(3) (2002) 481-487.
- [7] G. P. Zhang , Y. M. Huang, W. H. Shi, W.P. Fu, Predicting dynamic behaviors of a whole machine tool structure based on computer-aided

- engineering, *International Journal of Machine Tools & Manufacture*, 43 (2003) 699-706.
- [8] K. J. Johnson, Contact mechanics, *Cambridge University Press* (1985).
- [9] H. Ohta, Sound of linear guideway type recirculating linear ball bearings, *Trans. ASME, Journal of Tribology*. 121 (1999) 678-685.
- [10] H. Ohta, E. Hayashi, Vibration of linear guideway type recirculating linear ball bearings, *Journal of Sound and Vibration*. 235(5) (2000) 847-861.
- [11] J. C. Chang, J. S. S. Wu, J. P. Hung, Characterization of the dynamic behavior of a linear guideway mechanism, *Structural Engineering Mechanics*. 25(1) (2007) 1-10.
- [12] J. P. Hung, Load effect on the vibration characteristics of a stage with rolling guides, *Journal of Mechanical Science and Technology*. 23(1) (2009) 92-102.
- [13] Hiwin Technologies Company. Hiwin linear guideway technical information. *Taiwan: Hiwin Company*; 2000. <http://www.hiwin.com>
- [14] Hiwin Technologies Company. Hiwin ballscrews technical information. *Taiwan: Hiwin Company*; 2000. <http://www.hiwin.com>
- [15] THK Technologies Company. THK Ball screw technical information: ball screw peripheral. <http://www.thk.com>.
- [16] THK CO., LTD., Features of the LM Guide, <http://www.thk.com>
- [17] K. J. Johnson, Contact mechanics, *Cambridge University Press* (1985).
- [18] D. E. Brewe, B. J. Hamrock, Simplified solution for elliptical-contact deformation between two elastic solid, *Trans. ASME, Journal of Lubrication Technology*. 99 (1997) 485-487.
- [19] J. A. Greenwood, Analysis of elliptical Hertzian contacts, *Tribology International*. 30 (1997) 235-237.
- [20] M. F. Zaeh, T. Oertli, Finite element modelling of ball screw feed drive systems, *Annals of the CIRP*. 53(1) (2004) 289-293.
- [21] C. Y. Lin, J. P. Hung, T. L. Lo, Effect of preload of linear guides on dynamic characteristics of a vertical column-spindle system", *International Journal of Machine Tools and Manufacture*. 5(8) (2010) 741-746.
- [22] Y. Altintas, E. Budak, Analytical prediction of stability lobes in milling, *Annals of the CIRP*. 44 (1) (1995) 357-362.
- [23] Gagnol, B.C. Bouzgarrou, P. Ray, C. Barra, Model-based chatter stability prediction for high-speed spindles. *International Journal of Machine Tools & Manufacture*. 47 (2007) 1176 - 1186.
- [24] E. Budak, Analytical models for high performance milling. Part I: Cutting forces, structural deformations and tolerance integrity. *International Journal of Machine Tools & Manufacture*. 46 (2006) 1478-1488.