

Stress Relaxation of Date at Different Temperature and Moisture Content of Product: A New Approach

D. Zare, M. Alirezaei, S.M. Nassiri

Abstract—Iran is one of the greatest producers of date in the world. However due to lack of information about its viscoelastic properties, much of the production downgraded during harvesting and postharvesting processes. In this study the effect of temperature and moisture content of product were investigated on stress relaxation characteristics. Therefore, the freshly harvested date (kabkab) at tamar stage were put in controlled environment chamber to obtain different temperature levels (25, 35, 45, and 55 °C) and moisture contents (8.5, 8.7, 9.2, 15.3, 20, 32.2 %d.b.). A texture analyzer TAXT2 (Stable Microsystems, UK) was used to apply uniaxial compression tests. A chamber capable to control temperature was designed and fabricated around the plunger of texture analyzer to control the temperature during the experiment. As a new approach a CCD camera (A4tech, 30 fps) was mounted on a cylindrical glass probe to scan and record contact area between date and disk. Afterwards, pictures were analyzed using image processing toolbox of Matlab software. Individual date fruit was uniaxially compressed at speed of 1 mm/s. The constant strain of 30% of thickness of date was applied to the horizontally oriented fruit. To select a suitable model for describing stress relaxation of date, experimental data were fitted with three famous stress relaxation models including the generalized Maxwell, Nussinovitch, and Pelege. The constant in mentioned model were determined and correlated with temperature and moisture content of product using non-linear regression analysis. It was found that Generalized Maxwell and Nussinovitch models appropriately describe viscoelastic characteristics of date fruits as compared to Peleg mode.

Keywords—Stress relaxation, Viscoelastic properties, Date, Texture analyzer.

I. INTRODUCTION

DATE fruit as a famous tropical fruits contains highest percentage of carbohydrate, including fructose and glucose. In addition to carbohydrate, the date fruits have remarkable amounts of protein, crude fiber, pectin, tannins, minerals, and vitamins [1]. Rheological characteristics of foodstuff are essential for designing harvesting, handling, sorting and packaging equipments and processes. Agricultural materials constitute of both viscous and elastic elements, once undergone a deformation showed viscoelastic properties [2].

D. Zare is with Department of Agricultural Engineering, Shiraz University, Shiraz, Iran (P. O. Box: 7144165186, e-mail: dzare@shirazu.ac.ir).

M. Alirezaei is former graduate student in Department of Agricultural Engineering, Shiraz University, Shiraz, Iran (email: khorava@gmail.com).

S. M. Nassiri is with Department of Agricultural Engineering, Shiraz University, Shiraz, Iran (P. O. Box: 7144165186, e-mail: smnassiri@yahoo.com).

Wherever each of viscous and elastic elements has dominant effect, materials show different resistance to applied load. Viscoelastic characteristics of materials have been studied by transient test, including stress relaxation, creep, and dynamic tests. In stress relaxation test, behaviour of material is determined in stress-time coordinate when a constant strain is applied [3]. Number of research were conducted on viscoelastic characteristics of different agricultural materials such as raisin [4], banana and plantain [5] and potato tissue [6] by means of stress relaxation. The viscoelastic properties of eight Saudi date cultivars in two stage of maturity were studied by Hassan et al. [7]. The moisture content of all dates was more than 19% (w.b.). They reported that the date fruit exhibited viscoelastic properties.

In recent decades computer vision was extremely used to reduce human involvement, increase efficiency, and cost effectiveness [8]. The image acquisition and processing technique have created new food quality monitoring methods. It has good accuracy to appearance geometric measurement [9-11]. Hassan et al. used a white paper between impression inky sample and disk plunger, and then the footprint of sample contact area was scanned and processed to determine the contact surface area [7].

Iran with more than one million ton date fruit production per annum has been ranked second among date producers. However, due to improper processing of this product it has not received appropriate position in the world market [12]. Amongst the date varieties, Kabkab date is one of the delicious and sap full cultivars in Iran which has exported to the other countries. The main objective of the study is determine variation of viscoelastic characteristics of Kabkab variety as function of temperature and moisture content by measuring true surface contact area using machine vision technique.

II. MATERIALS AND METHODS

A. Theoretical consideration

General Maxwell model is one of the suitable rheological models for describing the viscoelastic behaviour of agricultural materials [2,13,14] represented by the following equation:

$$\sigma(t) = \sigma_e + \sum_{i=1}^n \sigma_i \exp\left(-\frac{t}{\tau_i}\right) \quad (1)$$

where, $\sigma(t)$ is time dependent stress, σ_e is the stress in elastic element, σ_i is stress in combined viscous-elastic elements, t is time and τ_i is relaxation time of combined viscous-elastic

elements. The element of the model has been illustrated in Fig. 1.

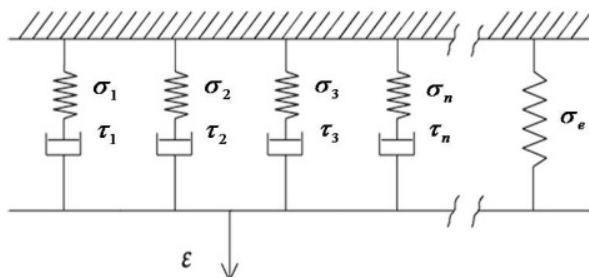

Fig. 1 The mechanical form of generalized Maxwell model

The number of elements is selected on the basis of maximum fit of model on measured stress relaxation data. Del Nobile et al. (2007) presented the ability of generalized Maxwell model for describing the stress relaxation behaviour of solid-like foods [3]. They prepared some bulky and spongy food substance and revealed that the proposed model satisfactorily fits with experimental data. Nussinovitch et al. simplified the General Maxwell model by assuming 10, 100, 1000, and so on for relaxation times of first, second, third and so on dashpot elements in model. The model has been formulated for three viscous elements as below [15]:

$$\sigma(t) = \sigma_0 \left(A_1 + A_2 \exp\left(\frac{-t}{10}\right) + A_3 \exp\left(\frac{-t}{100}\right) + A_4 \exp\left(\frac{-t}{1000}\right) \right) \quad (2)$$

In this model, $\sigma(t)$ is time dependent stress, σ_0 is the initial stress, t is time and $A_1, A_2, A_3,$ are constants.

Peleg and Pollak represented an empirical model based on the initial stress as follow [16]:

$$\sigma = \sigma_0 - \sigma_0 \left(\frac{abt}{1+bt} \right) \quad (3)$$

If $a=0$, the model represents the elastic behaviour, while if $a=1$, stress tended to zero in infinity time like liquid substance. The 'b' parameter exhibited the decay rate. If $b=0$, the stress never relaxed, whatever in low amount of 'b' the decay rate of stress relaxation is diminished slowly. The stress relaxation of banana's pulp was predicted using generalized Maxwell, Peleg and Nussinovitch models [5].

B. Experiment procedure Sample preparation

The Kabkab date fruits were manually picked up at Tamar stage of maturity (full ripened) from date palm trees in a garden, in Boushehr province, Iran. They were handled to the biophysics laboratory in Agricultural Engineering Department, Shiraz University, on the foam sheets in one layer arrays for minimizing any likely compaction. Then fruits sorted manually on the basis of its weight within the range of 7.2 to 7.9 g. Initial moisture content was determined by gravimetric method in an oven at 70°C till obtaining constant successive weight loss of 0.001 g. The initial moisture content was 24.7 %d.b. The samples kept in air tight container of supersaturated salt solution including LiCl, $KC_2H_3O_2$, $MgCl_2$, KNO_2 , $NaNO_2$ and NaCl for preparing different equilibrium moisture content (EMC) levels [17-18]. These salt solutions provided six

relative moisture content levels for creating the six EMCs in fruits. Containers were equilibrated in oven in 45°C and other temperature levels imposed to substance in experimentally measured time before testing. To avoid of weight lost samples packed in closed poly ethylene bags and put into oven before testing, therefore the moisture content lost was negligible (about 0.02% d.b.). The mean EMCs of fruits were measured 7.5%, 7.7%, 8.7%, 14.3%, 19.7%, and 31% (d.b.) in 9 replications. Variation of EMCs at different temperatures was measured and see to be negligible.

Stress Relaxation test

The TPA¹ (TA.XT2 plus model, Stable Microsystems, England) with Exponent Lite (Version 4,0,8,0, UK) software was used to compress whole date samples and export data into Excel worksheets. TPA was equipped with a 30 kg_f load cell. The cross head speed was adjusted on 1 mm/s, and samples compressed with 30% strain. The cross head then kept at 30% of strain for relaxing the stress in 300 s duration. A chamber with temperature controlling circuit was fabricated around the TPA cross head to prepare constant temperature identical to sample temperature with an accuracy of $\pm 0.1^\circ\text{C}$ during the stress relaxation tests (Fig. 2). All tests were performed with ten replications.



Fig. 2 Fabricated heating chamber around TPA cross head

A probe was designed so that it records contact area images while compressing the samples (Fig. 3). It constituted a CCD webcam camera (A4Tech, Model: PK-710MJ), several white beams LEDs, a 10 cm in diameter circular glass with 1 cm thickness, and a hollow Teflon cylinder. The CCD camera was connected to computer through USB2 port. Calibration of camera was done by a known dimensions black cube. Ten 320×240 pixels captures per second was created on line using image acquisition toolbox of MATLAB software (version R2007b). The visual information was quantified using image processing technique. Toluene was sprayed on samples to obtain distinct contact surface pictures.

¹ Texture profile analyzer

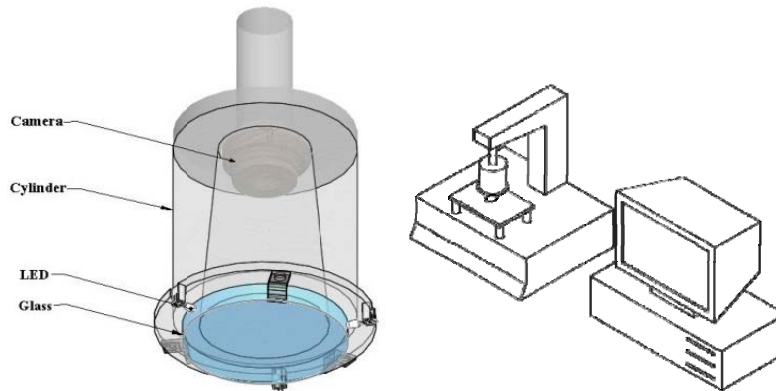

Fig. 3 a) The schematic of texture profile analyzer. b) designed probe with image recording while compressing samples

C. Statistical analysis

All coefficients and constants in three aforementioned models were obtained using non-linear regression (Levenberg-Marquadt) method in SPSS software (version 15.0, SPSS Inc.). Established models were verified by a new set of collected data and using criteria such as percent of average relative error (ARE %), standard error of estimation (SEE), and coefficient of determination R^2 [19].

$$ARE = \frac{100}{N} \times \sum \frac{|Y - Y'|}{Y} \quad (4)$$

$$SEE = \sqrt{\frac{\sum (Y - Y')^2}{df}} \quad (5)$$

III. RESULTS AND DISCUSSION

The imaging probe worked satisfactorily to detect visual properties. During the relaxation, slippage was not observed between sample and probe. As shown in Fig. 3, for instance, light parts are sample-probe contact area which is used to convert the force to true stress. The contact area had no variation whilst relaxation period. The area of captured images was quantified using image processing command. Results showed that there is positive correlation between the variation in area of contact surface and sample moisture content. Same trend has been observed for the effect of temperature (Fig. 4).

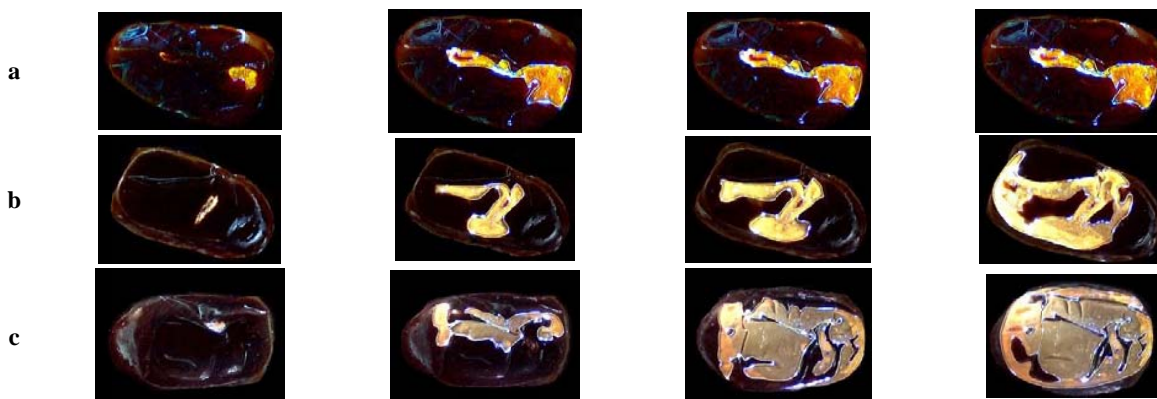

Fig. 4 The date fruit samples in compression, three moisture content levels, a) 7.7, b) 8.7 and c) 31 %, d.b. at 25°C. From left to right, samples were compressed gradually to 30% strain. The light colour shows contact surface area between sample and probe

It is obvious that there is noticeable change in area of contact surface when sample was compressed at higher moisture content levels. The higher contact surface area in samples with higher moisture content refers to considerable change in lateral dimensions. The force-time curves were converted to stress-time curve by dividing the true compression force values to corresponding true values of contact surface area. Trend of stress relaxation curves were similar to behaviour of time dependent materials such as banana [5]. Moreover, results revealed that increasing temperature of the date causes a decrease in stress response values. ,

This decrease was more significant in low moisture content levels. So that, a significant decrease was in moisture contents of 7.5 and 7.7 % (d.b.). As reported by Lewicki & Wolf, water as main component of foodstuff has important effect on chemical interaction and mechanical response [20].

Hence, each date fruit substance adsorbs certain amount of moisture at different relative humidities. The date sugars are in crystalline form at low moisture content, which increase date strength under deformation. Temperature increases sugars solubility in water. Moreover, in higher moisture content levels crystalline sugars uptake more water and transform to

amorphous structure [21] and thus, the strength of the date was reduced against compression. As a result, temperature had low effect on stress relaxation at higher moisture levels (Fig. 5). Maxwell model are given for different temperature and moisture content of the product in Table I. The constrain positive value for relaxation time was considered in formula. Nussinovitch model satisfactorily fitted on experimental data.

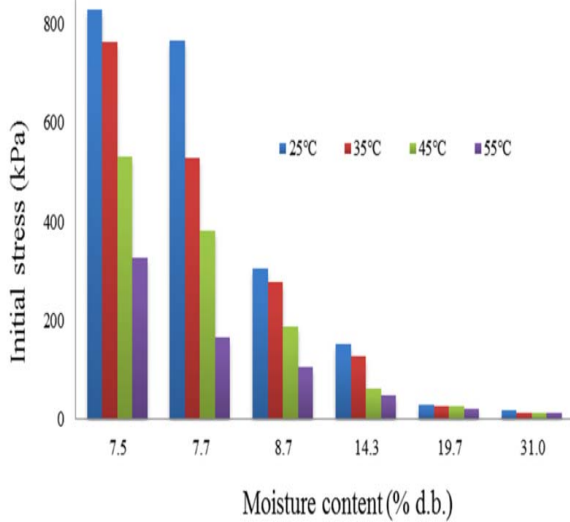

Fig. 5 Effect of temperature and moisture content on initial stress

The constants in the model were presented in Table II. Sakkie and Nabout date cultivars [7] approximately has the same Nussinovitch model constants at Rutab stage with range of 19.7 to 31% moisture content and 25°C of date temperature. Peleg constant ‘a’ was between 0.60 and 0.93 (Table III.). The highest values were in 7.5 and 7.7% moisture content, and lowest in 19.7%. According to Peleg model ‘a’ has direct correlation to stress response, so it depends on the date elasticity. In the present study ‘a’ values were same as those in Hassan et al. for eight cultivars of Saudi dates. The ‘b’ constant value was in range of 0.38 to 0.82 (1/s). As it clear from Fig. 6 General Maxwell and Nussinovitch models completely followed measured data.

TABLE I
THE GENERALIZED MAXWELL CONSTANTS

M.C. (% d.b.)	Temp (°C)	Stress (Kpa)					Relaxation time (sec)				Verification statistics		
		σ_1	σ_2	σ_3	σ_4	σ_5	τ_1	τ_2	τ_3	τ_4	ARE %	SEE	R ²
7.5	25	97.6	163.9	236.5	229.0	78.6	106.6	14.3	2.6	0.5	0.013	0.305	1.000
	35	220.7	239.2	82.7	133.1	64.7	2.8	0.4	109.6	15.2	0.012	0.319	0.976
	45	95.9	159.1	53.5	178.7	32.4	14.3	2.7	100.5	0.5	0.007	0.452	0.985
	55	88.9	90.0	53.0	36.1	43.7	2.4	0.3	14.3	101.8	0.007	0.286	0.987
7.7	25	240.1	136.1	220.2	86.3	62.9	2.8	14.8	0.4	109.4	0.011	0.328	0.992
	35	83.5	51.0	183.5	154.7	40.3	15.3	107.6	0.5	3.0	0.009	0.329	0.999
	45	140.5	106.8	33.4	61.7	26.6	0.5	2.6	93.8	13.4	0.007	0.389	0.999
	55	41.4	25.1	17.7	49.5	23.9	2.3	14.4	104.6	0.3	0.004	0.270	0.982
8.7	25	48.1	99.3	82.0	31.0	32.4	14.7	0.4	2.4	108.3	0.006	0.286	0.996
	35	41.6	28.3	90.1	73.9	30.7	14.7	105.3	0.3	2.4	0.006	0.312	0.992
	45	68.3	27.7	15.6	53.3	16.3	0.3	12.6	91.6	2.0	0.004	0.370	0.988
	55	16.7	28.1	26.4	11.2	19.5	12.5	0.3	2.1	89.5	0.002	0.194	0.989
14.3	25	43.9	52.8	13.4	23.1	13.4	1.7	0.2	85.2	11.1	0.003	0.558	0.987
	35	10.5	35.0	43.1	18.4	14.2	87.2	1.8	0.2	11.5	0.003	0.396	0.989
	45	13.8	-1.9E+06	3.8E+06	-1.9E+06	11.0	26.8	1.0	1.0	1.0	0.011	4.275	0.999
	55	11.3	11.7	5.5	7.5	10.8	1.5	0.2	63.5	8.6	0.001	0.406	0.954
19.7	25	6.6	8.2	4.1	3.3	6.4	1.9	0.2	13.5	149.5	0.002	0.871	0.996
	35	9.8	5076.1	5334.7	-10404.3	6.8	1.0	39.1	37.3	38.2	0.003	1.238	0.996
	45	5.3	10.1	288.6	-285.9	5.9	6.3	0.4	40.0	39.6	0.002	0.904	0.987
	55	226.0	6.9	3466.7	-3686.1	4.2	86.5	1.3	68.9	69.8	0.004	2.729	0.999
31	25	4.8	3.4	2.3	2.2	3.7	0.2	2.1	125.6	16.2	0.000	0.185	0.995
	35	3.5	1.8	2.0	2.8	2.7	0.2	15.6	129.6	2.0	0.000	0.262	0.983
	45	-13.1	50.1	-14.4	-18.3	2.9	33.1	33.1	33.1	33.1	0.005	6.550	0.967
	55	2.1	3.0	1.6	1.8	2.5	2.8	0.3	118.3	16.3	0.000	0.295	0.991

TABLE II
CONSTANTS AND STATISTICAL INDICES OF NUSSINOVITCH MODEL

M.C. (% d.b.)	Temperature, °C	Constants				Verification statistics		
		A ₁	A ₂	A ₃	A ₄	ARE %	SEE	R ²
7.5	25	0.007	0.394	0.076	0.118	0.23	1.94	0.899
	35	-0.011	0.381	0.064	0.129	0.27	8.46	0.945
	45	-0.041	0.402	0.049	0.135	0.17	3.20	0.969
	55	0.061	0.332	0.075	0.097	0.09	1.50	0.991
7.7	25	-0.024	0.394	0.061	0.144	0.23	2.52	0.923
	35	-0.030	0.380	0.044	0.142	0.17	2.77	0.959
	45	-0.033	0.373	0.031	0.134	0.13	3.27	0.988
	55	0.071	0.305	0.072	0.097	0.04	1.38	0.994
8.7	25	0.019	0.331	0.060	0.118	0.09	1.91	0.998
	35	0.029	0.320	0.062	0.110	0.08	1.95	0.997
	45	-0.004	0.318	0.032	0.118	0.06	2.66	0.985
	55	0.130	0.302	0.073	0.068	0.03	1.18	0.968
14.3	25	0.005	0.303	0.036	0.107	0.30	0.66	0.967
	35	0.030	0.292	0.034	0.106	0.04	0.02	0.984
	45	0.013	0.329	0.027	0.188	0.02	0.02	0.988
	55	0.241	0.269	0.090	-0.026	0.01	0.01	0.986
19.7	25	0.088	0.250	0.047	0.180	0.01	1.62	0.987
	35	0.115	0.236	0.056	0.165	0.01	1.78	0.995
	45	0.262	0.199	0.116	-0.077	0.01	1.88	0.997
	55	-0.084	0.271	-0.040	0.487	0.01	2.78	0.992
31	25	0.143	0.227	0.102	0.103	0.00	0.67	0.999
	35	0.109	0.237	0.108	0.132	0.00	0.74	0.989
	45	0.217	0.320	0.177	-0.005	0.00	4.79	0.987
	55	0.169	0.268	0.128	0.062	0.00	0.2	0.995

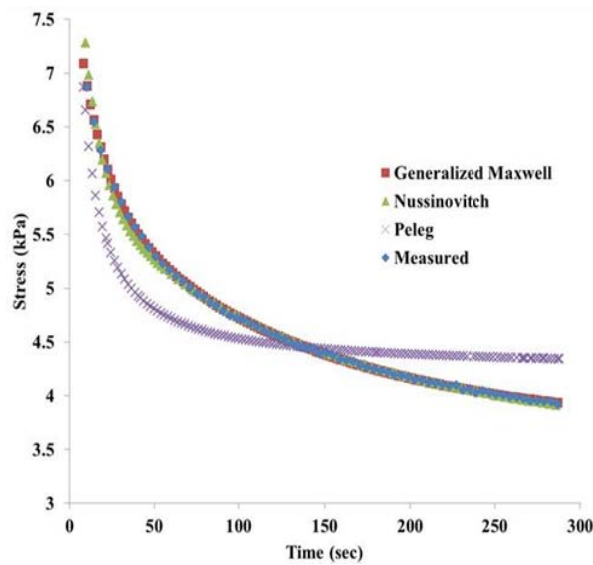

Fig. 6 The graphical representation of viscoelastic models (at 25°C and 30.98% MC)

TABLE III
THE PLEGE CONSTANTS

M.C. (% d.b.)	Constant	Temperature, °C			
		25	35	45	55
7.5	a	0.889	0.899	0.926	0.849
	b	0.381	0.441	0.479	0.459
	SEE	0.267	0.249	0.402	0.115
	ARE%	8.243	9.007	39.917	7.033
	R ²	0.876	0.846	0.919	0.899
7.7	a	0.901	0.909	0.920	0.838
	b	0.419	0.511	0.601	0.517
	SEE	0.244	0.156	0.101	2.485
	ARE%	9.278	9.304	9.080	450.921
	R ²	0.857	0.840	0.837	0.827
8.7	a	0.876	0.872	0.902	0.804
	b	0.537	0.555	0.763	0.497
	SEE	0.105	0.098	0.054	0.035
	ARE%	8.248	8.225	8.545	5.157
	R ²	0.915	0.895	0.923	0.885
14.3	a	0.901	0.876	0.829	0.767
	b	0.807	0.824	0.559	0.559
	SEE	0.047	0.038	0.921	0.048
	ARE%	9.035	7.382	419.670	20.781
	R ²	0.855	0.862	0.897	0.902
19.7	a	0.755	0.738	0.778	0.689
	b	0.570	0.555	0.747	0.471
	SEE	0.011	0.010	0.011	0.007
	ARE%	4.636	4.483	5.643	3.551
	R ²	0.915	0.889	0.899	0.915
31	a	0.755	0.765	0.771	0.763
	b	0.441	0.382	0.204	0.317
	SEE	0.008	0.007	0.007	0.005
	ARE%	6.339	6.972	8.657	5.932
	R ²	0.793	0.827	0.845	0.862

IV. CONCLUSIONS

The contact area of date fruit during relaxation test was suitably measured by a imaging acquisition probe. Results showed that the date fruits (Kabkab) has time dependent behavior as viscoelastic materials. The initial developed stress in fruit was highly dependent on moisture content than temperature. According to statistical indices the Generalized Maxwell and Nussinovitch model with four viscous elements

predict time dependent stresses in fruit with minimum residuals.

REFERENCES

- [1] J. S. Sidhu, "Date fruits production and processing. *In Handbook of fruit and fruit processing*," Blackwell Publishing, 2006.
- [2] N. N. Mohsenin, "Physical properties of plant and animal materials," Amsterdam: Gordon and Breach, 1986.
- [3] M. A. Del Nobile, S. Chillo, A. Mentana, A. Baiano, "Use of the generalized Maxwell model for describing the stress relaxation behavior of solid-like foods," *Journal of Food Engineering*, vol. 78, pp. 978-983, 2007.
- [4] P. P. Lewicki, "Rheological properties of raisins,": Part I: compression test. *Journal of Food Engineering*, vol. 24, pp. 321-338, 1995.
- [5] S. Kajuna, W. K. Bilanski, G. S. Mittal, "Effect of ripening on the parameters of three stress relaxation models for banana and plantain," *ASAE*, vol.14 (1), pp. 55-61, 1998.
- [6] M. Fincan, P. Dejmek, "Effect of osmotic pretreatment and pulsed electric field on the viscoelastic properties of potato tissue," *Journal of Food Engineering*, vol. 59, pp. 169-175, 2003.
- [7] B. H. Hassan, A. M. Alhamdan, A. M. Elansari, "Stress relaxation of dates at Khalal and Rutab stages of maturity," *Journal of Food Engineering*, vol. 66, pp. 439-445, 2005.
- [8] J. Lu, J. Tan, P. Shatadal, D. E. Gerrard, "Evaluation of pork color by using computer vision," *Meat Science*, vol. 56, pp. 57-60, 2000.
- [9] T. Brosnan, D. W. Sun, "Improving quality inspection of food products by computer vision—a review," *Journal of Food Engineering*, vol. 61, pp. 3-16, 2004.
- [10] D. J. Lee, R. Schoenberger, J. Archibald, S. McCollum, "Development of a machine vision system for automatic date grading using digital reflective near-infrared imaging," *Journal of Food Engineering*, vol. 86, pp. 388-398, 2008.
- [11] R. Chinchuluun, W. S. Lee, R. Ehsani, "Machine vision system for determining citrus count and size on canopy shake and catch harvester," *ASABE*, vol. 25 (4), pp. 451-458, 2009.
- [12] Anonymous, *Commodity production*. Retrieved 2012, from <http://faostat.fao.org/site/339/default.aspx>, 2010.
- [13] K. M. Waananen, M. R. Okos, "Stress relaxation properties of yellow-dent corn kernels under uniaxial loading," *ASAE*, vol. 35 (4), pp. 1249-3504, 1992.
- [14] J. F. Steffe, "Rheological methods in food processing engineering," East Lansing, MI, USA: Freeman Press, 1992.
- [15] A. Nussinovitch, M. Peleg, M. D. Normand, "A modified Maxwell and a non exponential model for characterization of the stress relaxation of agar and alginate gels," *Journal of Food Science*, vol. 54(4), pp.1013-1016, 1989.
- [16] M. Peleg, K. Pollak, "The problem of equilibrium conditions in stress relaxation analysis of solid foods. *Journal of Texture Studies*," vol. 13, pp. 1-11.
- [17] L. Greenspan, "Humidity fixed points of binary saturated aqueous solutions," *Journal of Research of the National Bureau of Standards*, vol. 81(A) (1), pp. 89-96, 1982.
- [18] T. D. Hong, R. H. Ellis, J. Gunn, D. Moore, "Relative humidity, temperature, and the equilibrium moisture content of conidia of *Beauveria bassiana* (Balsamo) Vuillemin: a quantitative approach," *Journal of Stored Products Research*, vol. 38, pp. 33-41, 2002.
- [19] D. Zare, S. Minai, M. Mohamad Zadeh, M. H. Khoshthaghaza, "Computer Simulation of Rough Rice Drying in a Batch Dryer," *Energy Conv. & Mang.* vol. 47, pp. 3241-3254, 2006.
- [20] P. Lewicki, W. Wolf, "Rheological Properties of Raisins," Part II. Effect of Water Activity. *Journal of Food Engineering*, vol. 26 (1), pp. 29-43, 1995.
- [21] R. M. Myhara, M. S. Taylor, B. A. Slominski, I. Al-Bulushi, "Moisture sorption isotherms and chemical composition of Omani Dates," *Journal of Food Engineering*, vol. 37, pp. 471-479, 1998.