

Active Vibration Control of Flexible Beam using Differential Evolution Optimisation

Mohd Sazli Saad, Hishamuddin Jamaluddin and Intan Zaurah Mat Darus

Abstract—This paper presents the development of an active vibration control using direct adaptive controller to suppress the vibration of a flexible beam system. The controller is realized based on linear parametric form. Differential evolution optimisation algorithm is used to optimize the controller using single objective function by minimizing the mean square error of the observed vibration signal. Furthermore, an alternative approach is developed to systematically search for the best controller model structure together with its parameter values. The performance of the control scheme is presented and analysed in both time and frequency domain. Simulation results demonstrate that the proposed scheme is able to suppress the unwanted vibration effectively.

Keywords—flexible beam, finite difference method, active vibration control, differential evolution, direct adaptive controller

I. INTRODUCTION

VIBRATION control has been widely applied in many applications including automotive, aircraft, electrical machinery and civil structures. Vibration occurs whenever a mechanical mechanism is moved intentionally or unintentionally. The unwanted vibration may cause damage to structures or degradation to system's performance. Therefore, many attempts have been proposed to reduce this unwanted disturbance by considering passive and active controls. Passive vibration control methods work well at high frequencies or in a narrow frequency range but often have the disadvantage of added weight and poor low frequency performance. Meanwhile, the potential of Active Vibration Control (AVC) to solve the problem has been demonstrated [1].

The concept of AVC was initially proposed by Lueg [2] for noise cancellation. AVC works based on artificially generating the cancellation signal to absorb the unwanted disturbance force that can reduce the effect of vibration to the system. Vibration suppression in AVC can be achieved by detecting and processing via suitable control schemes, thus the superimposed disturbance signals will cancel out the actual disturbance force. Several strategies based on closed-loop control scheme have been proposed in AVC system such as sliding mode control (SMC), fuzzy control (FC), self-tuning control and intelligent algorithms [3]-[4].

Mohd Sazli Saad is with the School of Manufacturing Engineering, Universiti Malaysia Perlis, Ulu Pauh Main Campus, 02600 Arau, Perlis, Malaysia (e-mail: sazlisaad@unimap.edu.my).

Hishamuddin Jamaluddin is a Professor at the Faculty of Mechanical Engineering, Universiti Teknologi Malaysia. He obtained his Doctor of Philosophy degree in 1991, from Sheffield University, U.K. His research interests include System Identification, Vehicle Dynamics, and Intelligent Control System. (e-mail: hishamj@fkm.utm.my).

Intan Zaurah Mat Darus is an Associate Professor in the Department of System Dynamics & Control, Faculty of Mechanical Engineering, Universiti Teknologi Malaysia. (e-mail: intan@fkm.utm.my).

AVC problem of flexible beams has attracted significant interest due to its generic nature and easily applied in many practical problems such as robot manipulators, aircrafts, electrical machines and civil structures. The development of various control strategies has been widely studied where the performance of the control schemes has been analyzed via simulation and experimental studies. Haichang and Song [5] proposed robust model reference controller and shown the robustness and effectiveness of the proposed method even in the presence of varying modal frequency due to changes in the mass of the flexible beam. Itik *et al.* [3] employed sliding mode control and H infinity control schemes using state space modeling approach. By performing experimental identification method, an estimated transfer function which represents the system was formed. The two control strategies were applied to the same system and the experimental results showed the success of the control approaches. Fei [6] also revealed that, the used of adaptive feed-forward sliding mode control and model reference adaptive sliding mode control are effective in vibration suppression problem.

Evolutionary algorithms have proven to be one such popular alternative in active vibration control optimization since the last two decades [7]-[8]. The evolutionary algorithm (EA) is a robust search and optimization methodology that is able to cope with ill-behaved problem domains, exhibiting attributes such as multimodality, discontinuity, time-variance, randomness, and noise. Recently, a group of researchers have come out with direct adaptive control using EA as controller optimization method. This controller has been created based on the indirect controller optimization initially proposed by Tokhi and Hossain [9]. For indirect controller optimization method, controller is designed based on the identified model. The performance of this controller depends on how accurate the model is identified. But, for direct controller optimization, its performance depends on the ability of optimization algorithms to produce the best global minimum of the fitness value. The effectiveness of indirect and direct optimization controller in suppressing the unwanted vibration has been demonstrated in simulation platform using FD methods. Hashim *et al.* [10] investigated the development of direct adaptive controller used genetic algorithm (GA) as the optimization algorithm in AVC of flexible beam system. A significant amount of vibration cancellation over a broadband of frequencies has been achieved. Julai *et al.* [11] proposed active vibration control (AVC) of a flexible plate structure using continuous ant system algorithm (CASA). Julai *et al.* [12] also developed a direct PSO-AVC mechanism which involves direct optimization of the controller parameters based on minimization of the error signal (observed signal). This approach does not require knowledge of the input/output characterization of the system for controller design. Mohamad

et al. [13] presented the utilization of continuous ant colony optimization algorithm intended for active vibration control of flexible beam structures. The performance of the system was presented in both time and frequency domains and the simulation results reveal that good performance is achieved using this approach.

Recently, differential evolution (DE) has been found to be a promising algorithm in numerical optimization problems. DE has been designed to fulfill the requirement for practical minimization technique such as consistent convergence to the global minimum in consecutive independent trials, fast convergence, easy to work with, as well as ability to cope with non-differentiable, non-linear and multimodal cost functions [14]. Therefore, the algorithm has gained a great attention since it was proposed. Ruijun [15] studied the performance of DE and particle swarm optimization (PSO) in optimizing PID controller for first order process. DE has found to be more robust (with respect to reproducing constant results in different runs) than PSO. Pishkenari [16] utilized DE algorithm to optimize the membership functions of a fuzzy controller for mobile robot trajectory tracking where the performance of the optimized controller is better than the traditional fuzzy controller. Yousefi *et al.* [17] applied DE algorithm to find the best values for the unknown parameters of a servo-hydraulic system with a flexible load. Results have revealed that DE algorithm accurately identified the time delay, structure and parameters of the system with a fast convergence rate. Youxin and Xiaoyi [18] has applied DE algorithm in tuning the PID controller for electric-hydraulic servo system of parallel platform. Simulation results show that the optimized PID controller has improved the performances of the electric-hydraulic servo system.

This research aims to provide an alternative control scheme using direct optimisation controller based on differential evolution algorithm in attenuating the unwanted vibration of flexible beam system. The parameters in linear parametric controller structure is optimize based on mean square error of the observed signal. In this method, the control design does not require knowledge of the input/output characteristics. The proposed control scheme used the random search capability of DE to directly update the required controller characteristic based on measurement the observed signal and is very likely to achieve the global minimum in the performance index surface. Furthermore, an alternative method has been proposed in order to select the best controller model structure and its parameter using optimization EA algorithm.

The rest of the paper is structured as follow: Section 2 briefly describes the fundamental theory of DE, Section 3 describes a flexible beam system and the development of a simulation environment characterising its dynamic behavior for use as a platform for test and verification of the proposed control approach, Sections 4 and 5 respectively introduce the proposed DE based active control system design and presents the implementation of the proposed strategy, Section 6 presents the associated results in a flexible beam system, and finally the paper is concluded in Section 7.

II. DIFFERENTIAL EVOLUTION ALGORITHM

Differential evolution (DE) algorithm is a stochastic, population-based optimization algorithm recently introduced. Unlike simple GA that uses binary coding for representing problem parameters, DE uses real coding of floating point numbers. The crucial idea behind DE is a scheme for generating trial parameter vectors. Basically, DE adds the weighted difference between two population vectors to a third vector.

The key parameters of control are: NP - the population size, CR - the crossover constant, F - the weight applied to random differential (scaling factor). It is worth noting that DE's control variables, NP , F and CR , are not difficult to choose in order to obtain promising results. The proposer of DE has come out with several rules in selecting the control parameters. The rules are listed below:

- 1) At initialization the population should be spread as much as possible over the objective function surface.
- 2) Frequently the crossover probability $CR \in [0,1]$ must be considerably lower than one (e.g. 0.3). If no convergence can be achieved, $CR \in [0.8, 1]$ often helps.
- 3) For many applications $NP=10 \times D$ is a good choice. F is usually chosen at $[0.5, 1]$.
- 4) The higher the population size NP is chosen, the lower one should choose the weighting factor F .

These rules of thumb for DE's control variables which is easy to work with is one of DE's major contribution [14]. The detailed Differential Evolution algorithm used in the present study is explained in section 5.

III. MODELING OF THE FLEXIBLE BEAM SYSTEM

A flexible beam of length, L , in fixed-free mode is considered. A schematic diagram of the flexible beam is shown in Fig. 1. Force is applied at distance, x , from the fixed end at time, t , and the resulting deflection from it's stationary position is denoted by $u(x,t)$ and $y(x,t)$ respectively. The motion of the beam in transverse vibration is formulated by fourth-order partial differential equation (PDE) that yields the following equation[9]:

$$\mu^2 \frac{\delta^4 y(x,t)}{\delta x^4} + \frac{\delta^2 y(x,t)}{\delta x^2} = \frac{1}{m} u(x,t) \quad (1)$$

where $u(x,t)$ is the actuating force applied at a distance, x , from its fixed end at time, t , $y(x,t)$ is the beam's deflection at a distance, x , from its fixed end at time, t , μ is the beam constant represented by $\mu^2 = \frac{EI}{\rho A}$, with E , I , ρ and A representing

Young's modulus, moment of inertia, mass density and cross-sectional area respectively, and m is the mass of the beam. The model in (1) does not have damping, so there is no energy loss in the model mathematically. The boundary conditions at fixed and free end of the beam are given by:

$$y(0, t) = 0$$

$$\frac{\delta y(0, t)}{\delta x} = 0$$

$$M(L, t) = \frac{\delta^2 y(L, t)}{\delta x^2} = 0$$

$$V(L, t) = \frac{\delta^3 y(L, t)}{\delta x^3} = 0 \quad (2)$$

where M and V represent shear and bending moments of the beam respectively.

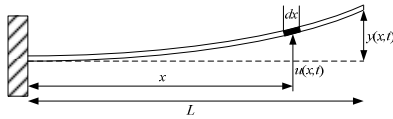

Fig. 1 Schematic diagram of a flexible beam system

Finite difference (FD) method is chosen to obtain the numerical solution of the PDE in (1). Simulations of flexible plate and beam via FD method are easy to implement and the method has been proven effective in investigating dynamics behavior of structures [4], [19]-[20]. The beam is discretized into a finite number of equal-length sections (segments), each of length, Δx , and the deflection of beam at the end of each segment is sampled at a constant time, Δt . By using first-order central finite difference, the PDE in (1) becomes:

$$Y_{j+1} = -Y_{j-1} - \lambda^2 S Y_j + \frac{\Delta t^2}{m} U(x, t) \quad (3)$$

where $U(x, t)$ is an $n \times 1$ matrix which represents the actuating force applied on the beam, Y_k , ($k = j-1, j, j+1$) is an $n \times 1$ matrix which is the deflection of the beam at segment 1 to n at time step k and S is known as stiffness matrix, which give the characteristic of the beam and $\lambda^2 = \left[\frac{(\Delta t)^2}{(\Delta x)^4} \right] \mu^2$. The dynamic behavior of the beam can be simulated using (3), which can be programmed easily via any digital programming software. In this research, Matlab software was used to model (3). The simulation platform is designed so that user can easily study the cases of any number of segments, length of the beam, different excitation signals and other simulation requirements.

Before executing the simulation model, the parameters of the beam given in Table 1 were set into the Matlab script. Then the sampling time was set to be 0.3 ms in order to satisfy the convergence requirement for the simulation in which λ^2 must be properly chosen between $0 < \lambda^2 \leq 0.25$ [21]. The above sampling time is also sufficient to cover a broad range of dynamics of the flexible beam.

TABLE I
BEAM SPECIFICATIONS

Parameter	Value
Number of segment	20
λ	0.3629
Mass	0.037 kg
Length	0.635 m
Beam constant	1.351

IV. DIRECT ADAPTIVE CONTROL SCHEME

Direct adaptive controller scheme using differential evolution algorithms is used in active vibration control for flexible beam. The aim of this controller is to suppress the unwanted vibration of the beam by means of optimisation method. Fig. 2 illustrates the block diagram of active vibration control using differential evolution direct optimisation controller scheme. An unwanted disturbance signal emits broadband disturbance into the structure which is detected by a detector. Then, the detector senses the disturbance signal and feed to a controller. The controller will determine the amount of actuator signal to reduce the level of vibration at an observation point along the structure.

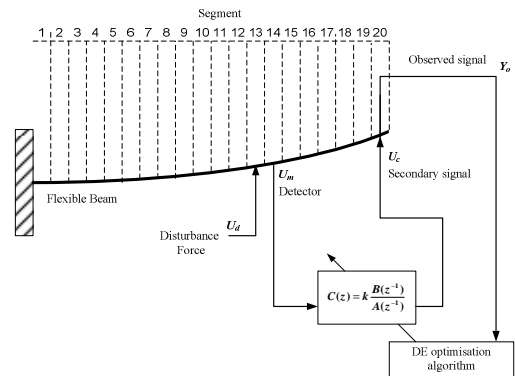

Fig. 2 DE AVC of flexible beam using DE direct adaptive controller

In this study, the aim of the controller design is to minimize the deflection Y_o via the actuator forcing signal, U_c for generating anti-phase control signal to counteract the vibration produced by U_d . Optimal vibration reduction can be achieved by DE optimisation method based on the observed signal Y_o . The controller is realized in a linear parametric form as:

$$U_c(t) = -a_1 U_c(t-1) - a_2 U_c(t-2) - \dots - a_n U_c(t-n) + b_0 U_m(t) + b_1 U_m(t-1) + \dots + b_m U_m(t-m) \quad (4)$$

where n and m are the order of lags for the denominator and numerator of the controller model order structure.

DE optimisation method is designed in such that it can be used to find the best controller structures as well as its parameter in order to yield optimum cancellation of broadband vibration at the observation point along the beam. The fitness function used in the optimisation algorithm is based on the mean square error of observed deflection signal, Y_o which is formulated as:

$$f(e) = \frac{1}{N} \sum_{i=1}^N (|Y_o|)^2 \quad (5)$$

where N represents the number of output samples. With the fitness function, the global search technique of the DE is utilized to obtain the best parameters and order structures of the controller.

V. IMPLEMENTATION OF DE CONTROLLER OPTIMISATION

Differential evolution (DE) algorithm is a heuristic optimization algorithm recently introduced. Unlike simple GA that uses binary coding to represent the parameters, DE uses real coding of floating point numbers. The crucial idea behind DE is a scheme for generating trial parameter vectors. Basically, DE adds the weighted difference between two population vectors to a third vector.

The key parameters of control are: NP - the population size, CR - the crossover constant, F - the weight applied to random differential (scaling factor). It is worth noting that DE's control variables, NP , F and CR , are not difficult to choose in order to obtain promising results. Storn [22] have come out with several rules in selecting the control parameters. The rules are listed below:

- 1) The initialized population should be spread as much as possible over the objective function surface.
- 2) Frequently the crossover probability $CR \in [0,1]$ must be considerably lower than one (e.g. 0.3). If no convergence can be achieved, $CR \in [0.8, 1]$ often helps.
- 3) For many applications $NP=10 \times D$, where D is the number of problem dimension. F is usually chosen at $[0.5, 1]$.
- 4) The higher the population size, NP , the lower the weighting factor F should choose.

These rules of thumb for DE's control variables which is easy to work with is one of DE's major contribution [14].

The detailed Differential Evolution algorithm used in tuning the PID controller is presented below:

A. Setting DE Parameter Optimisation

All the DE optimization parameter required for optimization process is listed below:

- D - problem dimension
- NP, CR, F - control parameters
- G - Number of generation/stopping condition
- L, H - boundary constraints

In this study, population size, $NP = 65$, crossover constant, $CR = 0.8$, mutation constant, $F = 0.5$, and the number of generation $G = 100$. The problem dimension, D is set based on the number of controller parameters, numerator order, denominator order and controller gain, k , used in the objective function. In the previous study, controller model order selection has been done by a trial-and-error method. Now, an alternative approach has been developed to systematically search for the best controller model structure together with its parameter values. The range for controller model order has been set from 0 to 5 ($m = n = 0$ to 5) which mean the problem dimension, $D = 13$. Fig. 3 illustrates the individual of solution space in problem dimension. Individual in problem dimension, D :

k	a_1	a_2	a_3	a_4	a_5	b_1	b_2	b_3	b_4	b_5	m	n
-----	-------	-------	-------	-------	-------	-------	-------	-------	-------	-------	-----	-----

Fig. 3 Problem dimension

The boundary constraint is set based on the individual parameter range. For example, controller parameters a and b are set at the interval of $[-1, 1]$, it means that low boundary, $L = -1$ and high boundary, $H = 1$. Details information about DE initial setting is shown in Fig. 4.

```

D=13; %dimension of problem
NP=65; %Population size
F=0.5; %differentiation constant
CR=0.8; %crossover rate
GEN=100; %generations
%order
Lm=1; %low boundary constraint 1Kp
Hm=5; %high boundary constraint 1
Ln=1; %low boundary constraint 2a1
Hn=5; %high boundary constraint 2
%parameter
L1=0; %low boundary constraint 1Kp
H1=1000; %high boundary constraint 1
L2=-1; %low boundary constraint 2a1
H2=1; %high boundary constraint 2
L3=-1; %low 0boundary constraint 3 a2
H3=1; %high boundary constraint 3
L4=0; %low 0boundary constraint 4 b1
H4=1; %high boundary constraint 4

```

Fig. 4 DE parameter setting

B. Vector Population Initialisation

Initialize all the vector population randomly in the given upper and lower bound and evaluate the fitness of each vector.

$$Pop_{ij} = L + (H - L) \cdot rand_{ij}(0,1), \quad i = 1, \dots, D, j = 1, \dots, NP. \quad (6)$$

$$Fit = f(Pop_j) \quad (7)$$

Before the optimization is launched the population needs to be initialized and its fitness function needs to be evaluated. The population is initialized randomly within its boundary constraints is done using (6). Each of the individual in the population is used to compute the fitness value which referred as MSE. The fitness value is computed by the fitness function as in (7) which is referring to active vibration control of flexible beam. Fig. 5 shows the block diagram of population and its corresponding fitness value. For example, if control parameters, a and $b \in [-1, 1]$, controller gain, $k \in [0, 1000]$, and controller model order, m and $n \in [1, 5]$, population and fitness values are calculated as:

For controller gain, $k \in [0, 1000]$,
 $Pop_{1,1} = 0 + (1000 - 0)rand_{1,1}(0,1)$
 $Pop_{1,1} = 688.8 = k$

For parameter, $a_i \in [-1, 1]$,
 $Pop_{1,2} = -1 + (1 - (-1))rand_{1,2}(0,1)$
 $Pop_{1,2} = 0.5944 = a_1$

For controller model order, $m \in [1, 5]$,
 $Pop_{1,12} = 1 + (5 - 1)rand_{1,12}(0,1)$
 $Pop_{1,12} = 10.4714 = m$

Then, the value of individuals are sent to the objective function which is the AVC of flexible beam system to compute for fitness value (refer to Fig. 5 below).

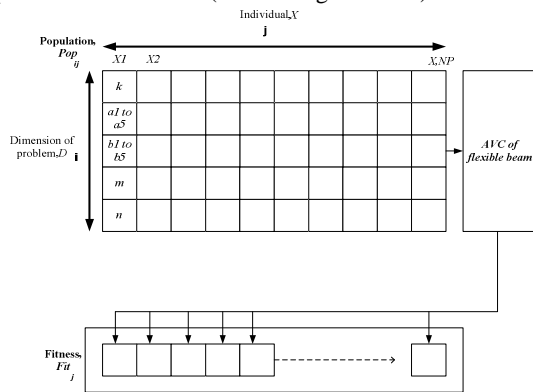

Fig. 5 The block diagram of population and its corresponding fitness value

C. Perform Mutation and Crossover

Whenever initialization process is done, the optimization process is executed. The optimization process will run iteratively until the end of generations. By referring to Fig. 6, the first individual fitness value from the current population is set to be the target vector. Then the trial vector is created by selecting three individuals randomly from the current population, mutate using (8) and crossover with the target vector. The fitness value (MSE) of the trial vector is computed by sending its individuals to the fitness function.

i) Mutant vector

For each vector $x_{j,G}$ (target vector), a mutant vector is generated by:

$$v_{j,G+1} = x_{r3,G} + F.(x_{r1,G} - x_{r2,G}) \quad (8)$$

Where the three distinct vectors x_{r1} , x_{r2} and x_{r3} randomly chosen from the current population other than target vector $x_{j,G}$. The detail example how the mutant vector is determined is shown in Fig. 6.

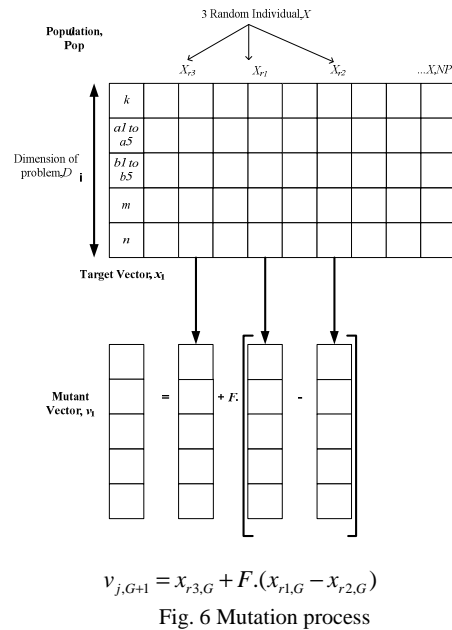

Fig. 6 Mutation process

ii) Crossover

Perform crossover for each target vector with its mutant vector to create a trial vector $u_{j,G+1}$.

$$u_{j,G+1} = (u_{1j,G+1}, u_{2j,G+1}, \dots, u_{Dj,G+1})$$

$$u_{ij,G+1} = \begin{cases} v_{ij,G+1} & \text{if } (rand_i \leq CR) \vee (Rnd = i) \\ x_{ij,G} & \text{otherwise} \end{cases}$$

$$i = 1, \dots, D$$

Crossover is done in order to increase the diversity of the perturbed controller parameters for each individual in the population. The block diagram on how this process is done is shown in Fig. 7.

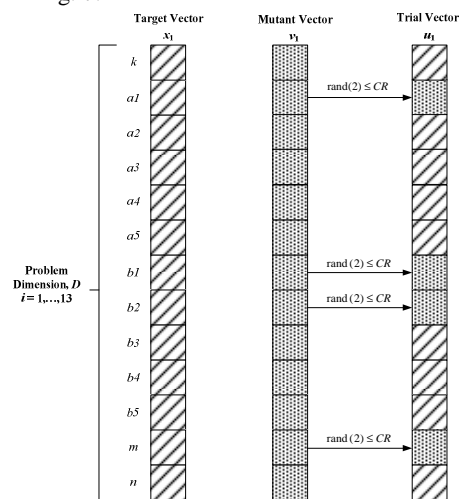

Fig. 7 Crossover process

D. Verifying the boundary constraint

If the bound (i.e. lower & upper limit of a variable) is violated then it can be brought in the bound range (i.e. between lower & upper limit) either by forcing it to lower/upper limit (forced bound) or by randomly assigning a value in the bound range (without forcing).

$$\text{if } x_i \notin [L, H], \quad x_i = L + (H - L) \cdot \text{rand}_i(0,1) \quad (9)$$

Equation (9) is purposely used in order to make sure that all the parameter vectors are within its boundary constraints.

E. Selection

Performance of the trial vector and its parent is compared and the better one is selected. This method is also known as greedy selection. Selection is performed for each target vector, $x_{j,G}$ by comparing its fitness value with that of the trial vector, $u_{j,G}$. Vector with lower fitness value is selected for next generation. Fig. 8 shows how the selection process is performed. The process is repeated until a termination criterion is met. The flowchart shown in Fig. 9 summarizes the DE algorithm.

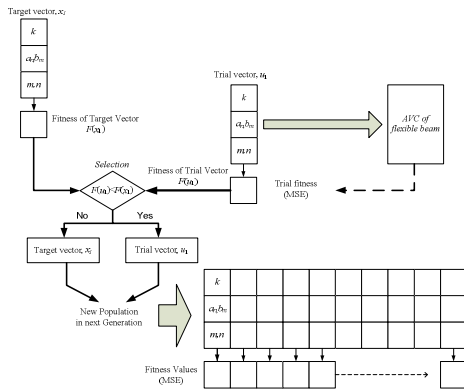

Fig. 8 Selection process

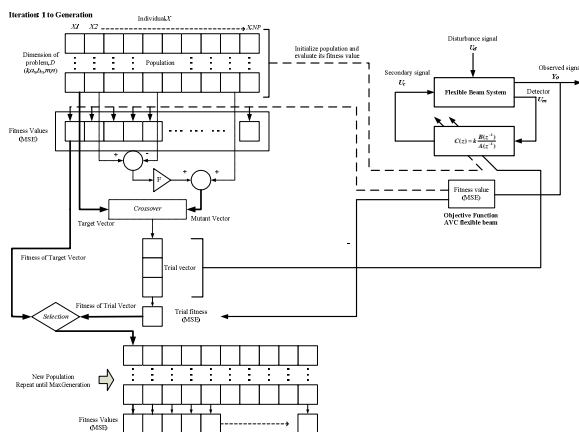

Fig. 9 Flowchart of differential evolution direct adaptive controller of AVC flexible beam system

VI. SIMULATION RESULTS

In this section, fixed free flexible beam with specifications in Table 1 was simulated. The beam was divided into 20 segments and a sampling time of 0.27078 ms that satisfies the stability requirement of the FD simulation model and is effectively to cover the resonance frequencies of vibration of the flexible beam. In order to study the performance on the proposed controller, sine disturbance signal with amplitude of 10V and frequency of 15 Hz was applied at segment 13 of the beam, and the control actuator signal was applied a segment 20. The detector and observed signal were placed at segment 14 and 20 respectively.

The proposed controller is design based on DE direct adaptive control. Differential evolution optimisation method is used to search for the best controller parameters including its optimum controller model structure. All these can be done in single optimisation approach. The search space for controller gain, controller parameters and controller model order is set based on Fig. 4. Since there was no prior knowledge about a suitable order of the controller, thus in this research an automated approach is proposed to search for the best controller model order within 1 to 5. The selection of DE optimisation parameters has great effect on the performance of the DE search algorithm, thus some guidelines are available [14]. Normally, NP should be chosen between 5 to 10 times the dimensions of problem. The value of F lies between 0.4 to 1.0 and for CR is from 0.1 to 1.0, but in general CR should be as large as possible for quick solution. In this study the number of generation, GEN , NP , F and CR were set to 100, 65, 0.5 and 0.8 respectively. The complete parameters setting can be seen in Fig. 4.

As shown in Fig. 10, DE optimisation achieved the best MSE levels of 2.424×10^{-10} m in the 96th generation with sine disturbance force signal. The optimum values for controller gain, controller parameters and controller model order are shown in Table 2. All these values have been search randomly using DE optimisation method in a way that a global minimum of MSE is achieved. This result reveal that the proposed method can be used to automatically search for the best controller model order by eliminating trial and error method proposed by previous studies [10], [13], [23].

The system performance with sine disturbance is shown in Figs. 11 and 12 which illustrate the time and frequency responses of the beam deflection respectively before and after control where a significant reduction of vibration level is achieved. It is observed that the spectral attenuations achieved at the first five resonance modes of the beam are 61.13 dB, 23.37 dB, 24.39 dB, 9.16 dB and 8.559 dB respectively (see Fig. 13). It shows that the power spectral density of the system reduces sufficiently at the first mode because the first vibration mode of system has large impact on overall system performance as it consist most of the vibration energy.

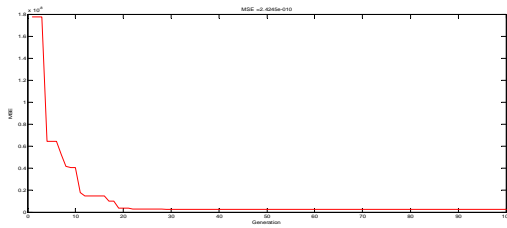

Fig. 10 DE convergence profile

TABLE II
IDENTIFIED CONTROLLER PARAMETERS

Controller gain, k	353.2				
Numerator order	3				
Denominator order	4				
Numerator parameter	a1	a2	a3	a4	a5
	-0.6524	-0.3644	-0.3393	-	-
Denominator parameter	b1	b2	b3	b4	b5
	-0.6373	-0.2260	0.2881	0.0923	-

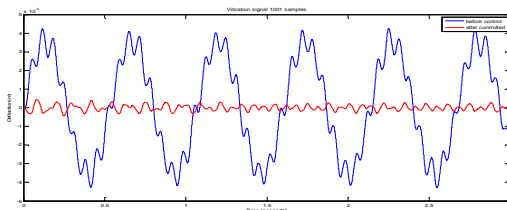

Fig. 11 Time domain responses

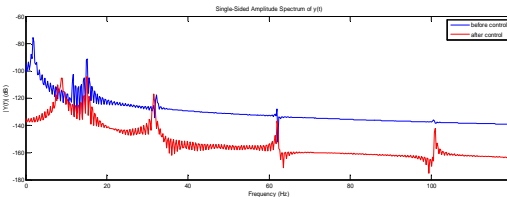

Fig. 12 Frequency domain responses

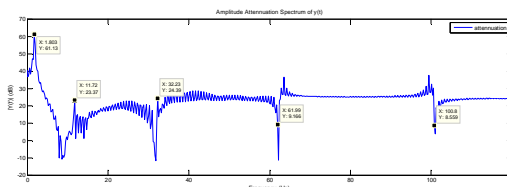

Fig. 13 Amplitude attenuation

VII. CONCLUSION

The design and implementation of an adaptive active control mechanism using DE optimisation algorithm has been presented and verified through simulation exercises in a flexible fixed-free beam system. The performance of the control system in vibration reduction with sine disturbance force signal has been assessed. It has been demonstrated that, a significant amount of vibration reduction over the full range of frequencies of the input signal has been achieved. The methodology proposed in this paper utilised DE optimisation to directly adjust controller parameters based on the MSE of observed signal at the tip of a flexible beam. The motivation gained with this approach is that no knowledge of the dynamic characterisation of the plant is needed for controller adaptation. The proposed method to automatically search for the best controller model order structure is able to work successfully without trial and error method.

ACKNOWLEDGMENT

The authors wish to thanks the Universiti Malaysia Perlis (UNIMAP) and Universiti Teknologi Malaysia (UTM) for providing the fund and facilities to conduct this research. This research is funded by Universiti Teknologi Malaysia Research University Grant Vote 00J20.

REFERENCES

- [1] F. Christopher, *Handbook of Noise and Vibration Control*. Virginia: John Wiley & Sons Inc, 2007.
- [2] P. Lueg, "Process of Silencing Sound Oscillations," U.S. Patent 2 043 416, 1936.
- [3] M. Itik, *et al.*, "Active Vibration Suppression of a Flexible Beam via Sliding Mode and H infinity Control," in *Proceedings of the 44th IEEE Conference on Decision and Control, and the European Control Conference*, Seville, Spain, 2005, pp. 1240-1245.
- [4] A. Madkour, *et al.*, "Intelligent Learning Algorithms for Active Vibration Control," in *IEEE Transactions On Systems, Man, And Cybernetics—Part C: Applications And Reviews*, 2007, pp. 1022-1033.
- [5] G. Haichang and G. Song, "Active Vibration Suppression of a Flexible Beam with Piezoceramic Patches Using Robust Model Reference Control," *Journal of Smart Materials and Structures*, vol. 16, pp. 1453-1459, 2007.
- [6] J. Fei, "Adaptive Sliding Mode Vibration Control Schemes for Flexible Structure System," presented at the Decision and Control 2007 46th IEEE Conference, New Orleans (USA), 2007.
- [7] A. R. D. Curtis, "An Application of Genetic Algorithms to Active Vibration Control," *Journal of Intelligent Material Systems and Structures*, vol. 2, pp. 472-481, October 1, 1991 1991.
- [8] C. T. Wangler and C. H. Hansen, "Genetic algorithm adaptation of non-linear filter structures for active sound and vibration control," in *Acoustics, Speech, and Signal Processing, 1994. ICASSP-94., 1994 IEEE International Conference on*, 1994, pp. III/505-III/508 vol.3.
- [9] M. O. Tokhi and M. A. Hossain, "A Unified Adaptive Active Control Mechanism for Noise Cancellation and Vibration Suppression," *International Journal of Mechanical Systems and Signal Processing*, vol. 10, pp. 667-682, 1996.
- [10] S. Z. M. Hashim, *et al.*, "Active Vibration Control of Flexible Structures Using Genetic Optimisation," *Journal of Low Frequency Noise, Vibration and Active Control*, vol. 25, pp. 195-207, 2006.
- [11] S. Julai, *et al.*, "Active Vibration Control of a Flexible Plate Structure Using Ant System Algorithm," in *Computer Modeling and Simulation, 2009. EMS '09. Third UKSim European Symposium on*, 2009, pp. 37-42.
- [12] S. Julai, *et al.*, "Active vibration control of a flexible plate structure using ant system algorithm," 2009, pp. 37-42.
- [13] M. Mohamad, *et al.*, "Continuous ant colony optimisation for active vibration control of flexible beam structures," in *Mechatronics (ICM), 2011 IEEE International Conference on*, 2011, pp. 803-808.

- [14] R. Storn and K. Price, "Differential Evolution – A Simple and Efficient Heuristic for Global Optimization over Continuous Spaces," *Journal of Global Optimization*, vol. 11, pp. 341–359, 1997.
- [15] D. Ruijun, "Differential Evolution Versus Particle Swarm Optimization for PID Controller Design," in *Fifth International Conference on Natural Computation, ICNC '09*, Tianjin, 2009, pp. 236-240.
- [16] H. N. Pishkenaria, *et al.*, "Optimum Synthesis of Fuzzy Logic Controller for Trajectory Tracking by Differential Evolution," *Scientia Iranica*, vol. 18, pp. 261-267, 2011.
- [17] H. Yousefi, *et al.*, "Application of Differential Evolution in system identification of a servo-hydraulic system with a flexible load," *Mechatronics*, vol. 18, pp. 513-528, 2008.
- [18] L. Youxin and C. Xiaoyi, "Tuning PID Control Parameters on Hydraulic Servo Control System Based on Differential Evolution Algorithm," in *Second International Conference on Advanced Computer Control (ICACC)*, Shenyang, 2010, pp. 348-351.
- [19] I. Z. M. Darus and M. O. Tokhi, "Soft Computing-based Active Vibration Control of a Flexible Structure," *Journal of Engineering Application of Artificial Intelligence*, vol. 18, pp. 95-114, 2005.
- [20] S. Z. M. Hashim, *et al.*, "Genetic Adaptive Active Vibration Control of Flexible Structures," presented at the Proceedings of ICS'04: IEEE SMC UK-RI Chapter Conference 2004 on Intelligent Cybernetic Systems, Londonderry (UK), 2004.
- [21] M. O. Tokhi and R. R. Leitch, *Active Noise Control*. Oxford, U.K.: Clarendon, 1992.
- [22] R. Storn, "On the Usage of Differential Evolution for Function Optimization," in *Proceedings of the Fuzzy Information Processing Society*, Berkeley, CA, USA, 1996, pp. 519-523.
- [23] S. Julai, *et al.*, "Control of a flexible plate structure using particle swarm optimization," in *Evolutionary Computation, 2009. CEC '09. IEEE Congress on*, 2009, pp. 3183-3190.



Mohd S. Saad was born in Jitra, Kedah, Malaysia, in December 21st, 1976. He received his diploma in Mechatronics from Polytechnic Sultan Abdul Halim (POLIMAS), Malaysia in 1997 and graduated from Universiti Teknologi Mara (UTM), Malaysia in Bachelor Degree of Electrical Engineering in 2002 and completed his Masters Degree (Mechatronic and Automatic Control) Electrical Engineering from Universiti Teknologi Malaysia (UTM), Malaysia in the year 2007. His field of research is in control engineering and currently extending his knowledge by undergoing PhD studies on Active Vibration Control in UTM. Mr. Mohd S. Saad also actively involves with Engineering Professional Bodies in Malaysia such as Board of Engineers, Malaysia (BEM).



Hishamuddin Jamaluddin is a Professor at the Faculty of Mechanical Engineering, Universiti Teknologi Malaysia. He teaches subjects such as Control System, Instrumentations, Multivariable System and System Identification for undergraduate and post graduate programmes. He obtained the Bachelor of Engineering (Control Engineering) degree in 1982, Master of Engineering (Control System) degree in 1985 and Doctor of Philosophy degree in 1991, from Sheffield University, U.K. His research interests include System Identification, Vehicle Dynamics, and Intelligent Control System.



Intan Z. M. Darus was born in Melaka, Malaysia, in September 16th, 1976. She received her First Class B.Eng (Hons.) degree in Mechanical Engineering from the University of Wales College Cardiff, Wales, United Kingdom in 1998 and later her Ph.D in Automatic Control and Systems Engineering from the University of Sheffield, United Kingdom in 2004. Currently, she is an Associate Professor in the Department of System Dynamics & Control, Faculty of Mechanical Engineering, Universiti Teknologi Malaysia. Her current research interests are active vibration control, modeling and simulation of dynamical system, soft computing and artificial intelligent techniques for system identification and control.