

# Methods for Analyzing the Energy Efficiency and Cost Effectiveness of Evaporative Cooling Air Conditioning

A Fouda, Z. Melikyan

**Abstract**—Air conditioning systems of houses consume large quantity of electricity. To reducing energy consumption for air conditioning purposes it is becoming attractive the use of evaporative cooling air conditioning which is less energy consuming compared to air chillers. But, it is obvious that higher energy efficiency of evaporative cooling is not enough to judge whether evaporative cooling economically is competitive with other types of cooling systems. To proving the higher energy efficiency and cost effectiveness of the evaporative cooling competitive analysis of various types of cooling system should be accomplished. For noted purpose optimization mathematical model for each system should be composed based on system approach analysis. In this paper different types of evaporative cooling-heating systems are discussed and methods for increasing their energy efficiency and as well as determining of their design parameters are developed. The optimization mathematical models for each of them are composed with help of which least specific costs for each of them are revealed. The comparison of specific costs proved that the most efficient and cost effective is considered the “direct evaporating” system if it is applicable for given climatic conditions. Next more universal and applicable for many climatic conditions system providing least cost of heating and cooling is considered the “direct evaporating” system.

**Keywords**—air, conditioning, system, evaporative cooling, mathematical model, optimization, thermoeconomic.

## I. INTRODUCTION

**A**IR conditioning systems are big consumers of electricity for operating their refrigerating machines. In many developed countries the peak of electricity consumption takes place in summer period because of operation of a great number of electric chillers based air conditioners. The cold produced by refrigerators is used for cooling the air before supplying into the served house. According to the statements of some authors to reduce energy consumption evaporative cooling type of air conditioning should be largely used. At present the evaporative cooling air conditioning systems can be classified by the following principles of the air processing: 1- different principles for evaporative cooling air conditioning are known, as direct and indirect. In its turn the indirect

evaporative cooling of air is divided into following two modes: 1- with preliminary cooling which is fulfilled by keeping the specific humidity of the outside air constant, 2- with preliminary draying of the outside air by the help of sorbents (desiccant materials).

To confirm or to deny the statements on energy efficiency and cost effectiveness of different types of evaporative cooling air conditioning detailed analysis should be applied. Methods for correct sizing and evaluating of each part or unit of different systems should be developed. The energy efficiency and cost effectiveness of each system should be revealed by the help of multi-factorial and multi-variable optimization analysis of systems. As a result of such analysis the system which provides the least cost of supplied and consumed energy for given climatic, energy and economic conditions should be selected to be used as preferable. The controlling factor of such analysis should be criteria reflecting the specific cost of cooling and heating, referred to 1m<sup>2</sup> of served house surface. The determination of energy efficiency and cost effectiveness of systems should be based on optimization procedures. That is to say, before comparisons of values of specific costs of cooling and heating the systems should be optimized for revelation of the least specific costs of energy for each type of evaporative cooling systems. The preferable will be considered the system which provides less specific cost.

## II. SYSTEMS DESCRIPTION

### A. Direct Evaporative Air conditioning Systems (DEACS)

The improved constructive and operative scheme of direct evaporative cooling air conditioning system which provides higher energy efficiency is represented in Fig.1. The air treatment processes for summer cooling regime are shown on the psychrometric chart of air in the Fig.2. The system operates both for summer cooling and winter heating in the following way:

A. Fouda, is with the Department of mechanical power engineering, Faculty of engineering, Mansoura University, Egypt, and PhD student in Yerevan State University of Architecture and Construction, Armenia, (corresponding author to provide phone+37410641785; e-mail: eng\_alifouda\_2007@yahoo.com).

Z. Melikyan, is with the Yerevan State University of Architecture and Construction, Armenia, Association of Energy Engineers (AEE), Armenia (e-mail: zohrabmelikyan@yahoo.com).

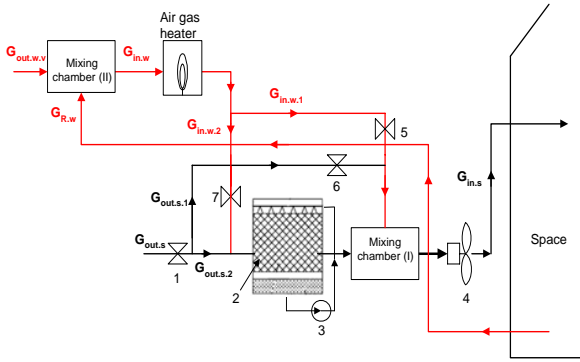

Fig. 1: Direct evaporative cooling AC system  
1, 5, 6, and 7 - valves; 2-air humidifier; 3- pump; 4-fan

1. Summer cooling regime

The outside air  $G_{out.s}$ , kg/sec under a temperature  $t_{out.s}$  and relative humidity  $\phi_{out.s}$  enters into the system through the open slide dumper (1) and is divided into two parts one of which  $G_{out.s.1}$ , kg/sec. directly flows to the mixing chamber (I) by a by-passing duct and open dumper (6) and the other part  $G_{out.s.2}$ , kg/sec. passes through the humidifier (2) where it is directly humidified and is cooled almost to its wet bulb point (process “O1-2” Fig.2) and then enters into mixing chamber (I) too. The cooled mixture of air (point S1, Fig.2) by the help of fan (4) is directed into the house space where absorbing excessive heat from the space is heated up to the required in the house temperature  $t_R, ^\circ C$  (process “S1-R” Fig. 2).

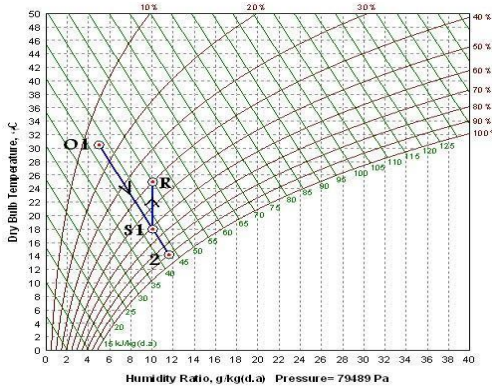

Fig. 2: Psychrometric chart of DEACS for summer Cooling regime

The quantity of outside air  $G_{out.s}$ , kg/sec. which should be supplied into the house is determined by the help of the chart and by the following formula:

$$G_{out.s} = Q_{cd} / (i_R - i_{S1}) \quad (1)$$

The quantity of air passing through the humidifier  $G_{out.2}$ , kg/sec. is determined by the following formula:

$$G_{out.2} = G_{out.s} (d_{s1} - d_{O1}) / (d_2 - d_{O1}) \quad (2)$$

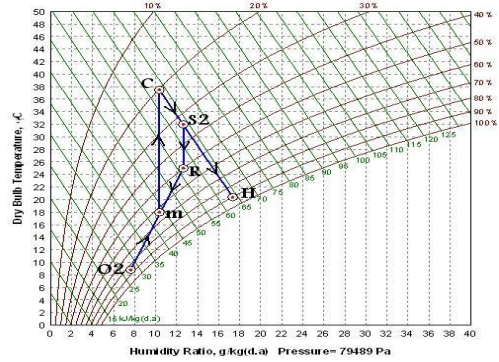

Fig. 3: Psychrometric chart of DEACS and of all other types of evaporative cooling systems for winter heating regime

where:  $Q_{cd}$ - cooling demand of the served house, kW,  $i_R$  and  $i_{S1}$ - enthalpies of processed air, kJ/kg,  $d_{O1}, d_2$  and  $d_{s1}$  - specific humidity of outside air, humidified air (point “2”, Fig.2) and of the mixture of airs (point “S1”, Fig.2.). Application of recirculation of inside air and by-passing allows reducing energy consumption. The cooling demand  $Q_{cd}$ , is determined by the method published in [1]:

2. Winter heating regime

The processes of the air treatment in the air conditioning system for winter heating regime are shown on the psychrometric chart of air in the Fig.3. The outside air flow  $G_{out.w.v}$ , kg/sec needed for ventilation of the house under a temperature  $t_{out.wint.}$  and relative humidity  $\phi_{out.wint.}$  enters into the mixing chamber (II), and is mixed with the air flow  $G_{R.w} = G_{in.w} - G_{out.w.v}$ , kg/sec which is returned from the house (the mixture point is “m”, Fig.3). The mixture of airs in the quantity  $G_{in.w}$ , kg/sec enters into gas heater where is heated (process “m-c”, Fig.3), and then is divided into two parts one of which  $G_{in.w.1}$ , kg/sec. directly flows to a mixing chamber (I) by the by-pass duct and open dumper (5) and the other part  $G_{in.w.2}$ , kg/sec. passes through the humidifier (2) where it is humidified and cooled almost up to its wet bulb point and then enters into the mixing chamber (I) too. Then the warm mixture of air by the help of fan (4) is directed into the house space where giving heat to the space is cooled up to required in the house temperature  $t_R, ^\circ C$ . The quantity of the air mixture which should be supplied into the house  $G_{in.wint.}$ , kg/sec. is determined by the help of the chart and by the following formula:

$$G_{in.w} = Q_{hd} / (i_{S2} - i_R) \quad (3)$$

The quantity of air for ventilation  $G_{out.w.v}$ , kg/sec is taken 20 m<sup>3</sup>/hr per person [2].

B. Indirect Evaporative Cooling Air Conditioning Systems (IEACS) With Preliminary Cooling Of Outside Air

This system allows providing cooler air in the outlet of the humidifier, thus it is applicable in more humid climatic conditions. The improved constructive and operative scheme

of indirect evaporative cooling air conditioning system with preliminary cooling of outside air which provides higher energy efficiency is represented in Fig.4. The system operates both for summer cooling and winter heating. The processes of the air treatment in the system for summer cooling regime are shown on the psychrometric chart of air in the Fig.5 and for winter heating regime in the Fig.3.

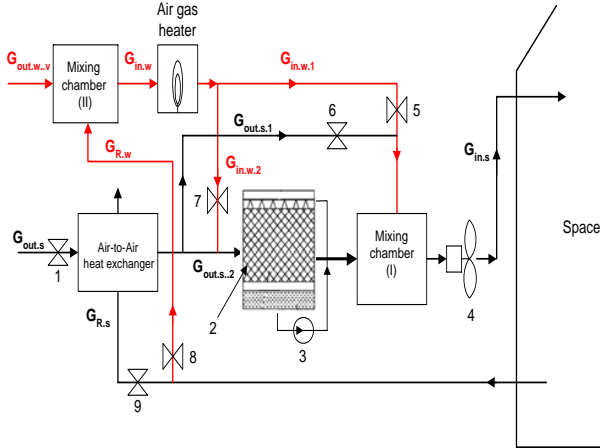

Fig. 4: Indirect evaporative cooling AC system  
1, 5, 6, 8, and 9 - valves; 2-air humidifier; 3- pump; 4-fan

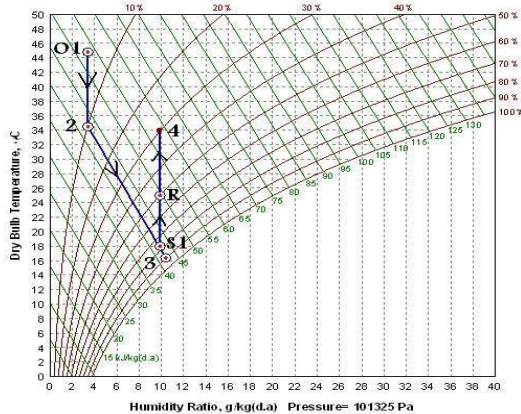

Fig. 5: Psychrometric chart of IEACS for summer cooling regime

### 1. Summer cooling regime

The outside air flow  $G_{out.s}$ , kg/sec under a temperature  $t_{out.s}$  and relative humidity  $\phi_{out.s}$  passing through the open dumper (1) enters into the air-to-air heat exchanger where it is cooled up to a temperature  $t_2$  (process "O1-2" Fig.5). As cooling medium serves the air flow  $G_{R.s} = G_{out.s}$ , kg/sec which is returned from the house having temperature  $t_R$ . Then the preliminary cooled outside ventilation air is divided into two parts one of which  $G_{out.s.1}$ , kg/sec. directly flows to a mixing chamber (I) by a by-pass duct and open dumper (6) and the other part  $G_{out.s.2}$ , kg/sec. passes through the humidifier (2) where it is humidified and cooled up almost to its wet bulb point (process "2-3" Fig.5.) and enters into the mixing chamber (I) too. Then the cold mixture of air (point

"S1" Fig.5.) by the help of fan (4) is directed into the house where absorbing excessive heat from the space is heated up to required in the house temperature  $t_R$ , °C (process "S1-R" Fig.5.). The outside air flow  $G_{out.s}$ , kg/sec is taken equal to the quantity of ventilation air  $G_{out.v}$ . The quantity of air  $G_{in}$ , to be supplied into the house is determined by the following formula:

$$G_{out.s} = Q_{cd} / (i_R - i_{S1}), \quad (4)$$

The air flow through the by-passing duct  $G_{out.s.1}$ , kg/sec. is determined by the following formula:

$$G_{out.s.1} = G_{out.s} (d_{s.1} - d_2) / (d_3 - d_2) \quad (5)$$

The energy balance of the air to air heat exchanger can be expressed by the following equation:  $G_{out.s} (i_{O1} - i_2) = G_{R.s} (i_4 - i_R)$  from which can be defined the correct value of  $i_4$  using the following equation:

$$i_4 = i_R + (i_{O1} - i_2) \quad (6)$$

### 2. Winter heating regime

The outside ventilation air flow  $G_{out.w.v}$ , kg/sec under a temperature  $t_{out.w}$  and relative humidity  $\phi_{out.w}$  enters into the mixing chamber (II), where is mixed with exhausted from the house air flow  $G_{R.w} = G_{in} - G_{out.w.v}$ , kg/sec. The mixture of air  $G_{in.w.}$ , kg/sec is heated in the gas heater, and then is divided into two parts one of which  $G_{in.w.1}$ , kg/sec. directly flows to a mixing chamber (I) by a by-pass duct with open dumper (5) and the other part  $G_{in.w.2}$ , kg/sec. passes through the humidifier (2) where it is cooled up almost to its wet bulb point and enters into the mixing chamber (I) too. Then the warm mixture of air by the help of fan (4) is directed into the house space where giving heat to the space is cooled up to required in the house temperature  $t_R$ , °C. The processes of air treatment are shown on the psychrometric chart of air in the Fig.3. The formula (3) also is used for heating regime of this system.

### C. Indirect Evaporative Air Conditioning Systems (IEACS) With Preliminary Drying of Air

For efficient use of evaporative air conditioning system in hot and wet climatic conditions it is becoming necessary to reduce artificially the specific humidity of outside air since as lower the initial specific humidity of the air as lower its dry bulb temperature. The preliminary drying of the outside air before its humidifying is fulfilled by using desiccant materials like silica gel. After having absorbed the water vapor from air the desiccant material is saturated by humidity and loses its capability of farther absorbing. For this reason the desiccant material should be reactivated by a stream of hot air. The most convenient way for air drying is the use of so called desiccant wheels containing silica gel. The wheel is divided into to segments. One of them contains activated silica gel, and the second contains saturated by humidity inactive silica gel. The wheel turns slowly and in each turn through the reactivated segment passes outside air and dried. At the same time through the saturated silica gel segment passes hot air and

reactivates the saturated silica gel. The preliminary drying of the outside air can be executed by one stage and two stages.

The improved constructive and operative scheme of evaporative air conditioning system with one stage of preliminary drying of the outside air by the help of desiccant wheel is represented in Fig.6. The processes of the air treatment in the air conditioning system for summer cooling regime are shown on the psychrometric chart of air in the Fig.7 and for winter heating regime in the Fig.3.

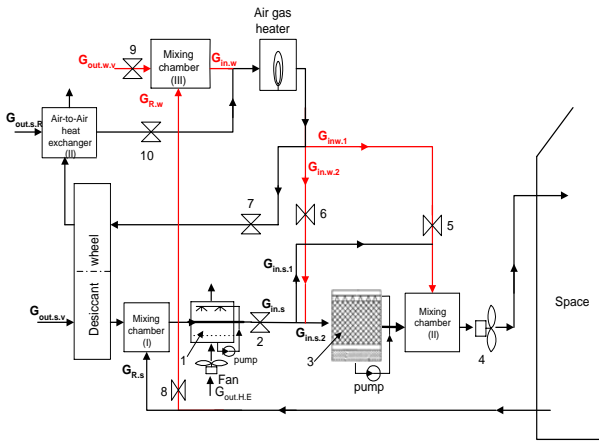

Fig. 6: Evaporative air conditioning System with one stage of preliminary drying of air (one desiccant Wheel  
1- evaporative type of air cooler 3- air humidifier; 2, 5, 6, 7, 8, 9 and 10 – dumpers; 4- fan

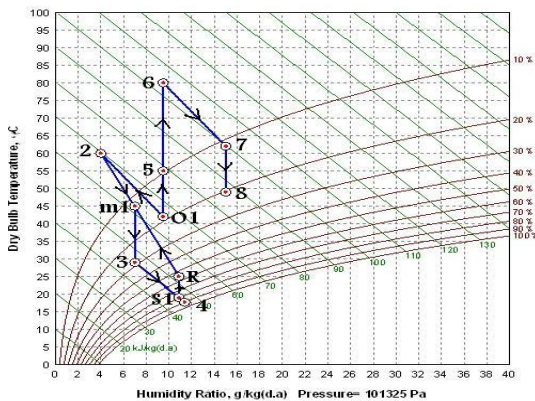

Fig.7: Psychrometric chart of Evaporative air conditioning System with one stage of preliminary drying of air for summer cooling regime

The system operates both for summer cooling and winter heating in the following way.

1. Summer cooling regime

the outside ventilation air flow  $G_{out.s.v}$ , kg/sec having parameters  $t_{out.s}$  and  $\phi_{out.s}$  enters into the reactivated segment of the desiccant wheel where it is dried (process O1-2, Fig.7.), and then enters into the mixing chamber (I), where it is mixed with air flow  $G_{R,s}$ , kg/sec exhausted from the house. The mixture then enters into evaporative type air cooler (1), where it is cooled up to a temperature  $t_3$  (point “3”, Fig.7.). Then the

cooled mixture is divided into two parts one of which  $G_{in.s.1}$ , kg/sec. by the by-pass duct directly flows to a mixing chamber (II) and the other part  $G_{in.s.2}$ , kg/sec. passes through the humidifier (3) where it is humidified and cooled (process “3-4” Fig.7.) up to almost its wet bulb point and enters into mixing chamber (II) too. Then the cooled mixture of air (point “S1”, Fig.7.) by the help of fan (4) from the mixing chamber (II) is supplied into the house space where absorbing excessive heat  $Q_{cd}$ , kW is heated up to required in the house space temperature  $t_R$ , °C (process “S1-R”, Fig.7). The quantity of cold mixture  $G_{in.s}$ , kg/sec. which is supplied into the house is determined by the following fraction:  $G_{in.s} = Q_{cd} / (i_R - i_{S1})$ . The quantity of outside ventilation air  $G_{out.s.v}$ , kg/sec. should be assumed according to the sanitary norms.

The energy balance of the air to air heat exchanger (II) can be expressed by the following equation:  $G_{out.s.R} (i_5 - i_{O1}) = G_{out.s.R} (i_7 - i_8)$  from which can be defined the correct value of  $i_8$  using the following equation:  $i_8 = i_7 - (i_5 - i_{O1})$  (7)

where: process “O1-5”, Fig.7 – heating of the outside air in the heat exchanger (II) by the heat of outlet air from the reactivation segment of desiccant wheel (process “7-8” fig.7), process “6-7” – cooling and humidification process of reactivation air in the reactivation segment of desiccant wheel, Process “5-6”, Fig.7 – additional heating of the reactivation air in the gas heater.

2. Reactivation of the saturated silica gel

In the desiccant wheel in summer cooling regime is fulfilled by the help of outside air which is preliminary heated in the air to air heat exchanger (process “O1-5” Fig.7) where it absorbs heat from the outlet air of the reactivation segment of desiccant wheel. Then the preheated air is finally heated up to  $t_6$  °C in the gas heater (process “5-6” Fig.7). The hot air passes through the saturated segment of desiccant wheel and absorbs the desiccant’s humidity. As a result the drying air is cooled and humidified by the process “6-7” as shown in the Fig.7. To realize the noted processes the desiccant wheel should have required constructive and thermal parameters. To determining parameters special mathematical model was developed by the authors of this paper [3].

3. Winter heating regime

The described evaporative cooling air conditioning system with one stage of preliminary drying of the outside air by the help of desiccant wheel is fulfilled analogically as for previews systems by the processes of air treatment shown in the Fig.3.

D. Evaporative Air Conditioning System with Two Stages of preliminary Drying of Outside Air with the help of two Desiccant Wheels

The necessity of use of two stages of preliminary drying of outside air rises in humid climatic conditions. In this case two desiccant wheels are installed in series. The constructive and operative scheme of suggested higher efficiency evaporative air conditioning system with two desiccant wheels is



represented in Fig.8. The processes of the air treatment in the air conditioning system for summer cooling regime are shown on the psychrometric chart of air in the Fig.9 and for winter heating regime in the Fig.3.

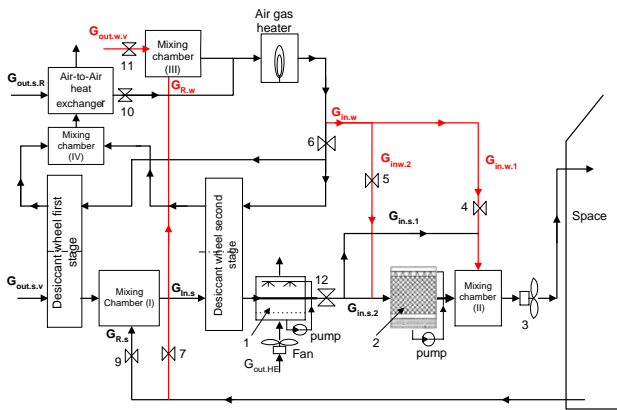

Fig. 8: Evaporative air conditioning System with two stages of preliminary drying of air  
 1- evaporative type air cooler; 4, 5, 6, 7, 8, 9, 10, and 11 - valves; 2- air humidifier; 3- fan

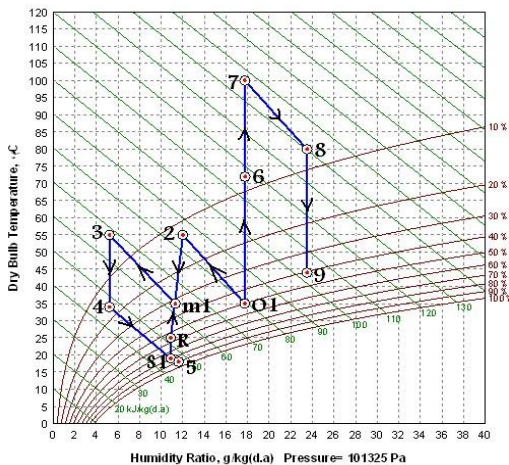

Fig. 9: Psychrometric chart of evaporative system with two stage preliminary drying of air for summer cooling regime

The system operates both for summer cooling and winter heating in the following way.

1. Summer cooling regime

The outside ventilation air flow  $G_{out.s.v}$ , kg/sec air having parameters  $t_{out.s}$  and  $\phi_{out.s}$  enters into the activated segment of the first desiccant wheel where it is dried (process O1-2, Fig.9.), and then enters into the mixing chamber (I). Into the mixing chamber (I) enters the inside air too having the quantity  $G_{R.s} = G_{in.s} - G_{out.s.v}$ , kg/sec. which is exhausted from the house through open dumper (9). The exhausted inside air has temperature  $t_R$ , which is much lower, than the temperature  $t_2$  of the outlet air from the first desiccant wheel. The mixture of airs  $G_{in.s}$  (point “m1”, Fig.9) then passes through the activated segment of the second desiccant wheel where it is dried again (process “m1-3”, Fig.9). The outlet air from the

second desiccant wheel (point “3”, Fig.9) passes through the evaporative type air cooler (1) where it is cooled by the evaporative type air cooler up to a temperature  $t_4$  (process “3-4”, Fig.9). Then the preliminary dried air is divided into two parts one of which  $G_{in.s.1}$ , kg/sec. by the by-pass duct directly flows to a mixing chamber (I) and the other part  $G_{in.s.2}$ , kg/sec. passes through the humidifier (2) where it is humidified and cooled up to almost its wet bulb point (process “4-5”, Fig.9.) and enters into mixing chamber (I) too. Then the cooled mixture of air (point “S1”, Fig.9) by the help of fan (3) from the mixing chamber (I) is directed into the house space where absorbing excessive heat  $Q_{cd}$ , kW is heated up to required in the house space temperature  $t_R$ , °C (process “S1-R”). The quantity of cold mixture  $G_{in.s}$ , kg/sec supplied into the house is determined by the following fraction:  $G_{in.s} = Q_{cd} / (i_R - i_{S1})$ .

The quantity of outside ventilation air  $G_{out.s.v}$ , kg/sec. should be assumed according to the sanitary norms. The energy balance of the air to air heat exchanger can be expressed by the following equation:

$$G_{out.s.R} (i_6 - i_{O1}) = G_{out.s.R} (i_8 - i_9)$$

from which can be defined the correct value of  $i_9$  using the following equation:

$$i_9 = i_8 - (i_6 - i_{O1}) \tag{8}$$

where: process “O1-6”, Fig.9 – heating of the outside air in the heat exchanger (II) by the heat of outlet air from the reactivation segment of desiccant wheel (process “8-9” Fig.9), process “7-8” – cooling and humidification process of reactivation air in the reactivation segment of desiccant wheel, process “6-7”, Fig.9 – additional heating of the reactivation air in the gas heater.

2. Reactivation of the saturated silica gel

In the both desiccant wheels in summer cooling regime is fulfilled by the help of outside air which is preliminary heated in the air to air heat exchanger (process “O1-6” Fig.9) where it absorbs heat from the outlet air of the reactivation segments of both desiccant wheels. Then the preheated air is finally heated up to  $t_7$  °C in the gas heater (process “6-7” Fig.9). The hot air two streams pass through the saturated segments of both desiccant wheels and absorb the desiccant’s humidity. As a result the drying air is cooled and humidified by the process “7-8” as shown in the Fig.9. To realize the noted processes the desiccant wheels should have required constructive and thermal parameters. To determining mentioned parameters special mathematical model was developed [3].

3. Winter heating regime

The described evaporative cooling air conditioning system with two stages of preliminary drying of the outside air by the help of desiccant wheels is fulfilled analogically as for previews systems by the processes of air treatment shown in the Fig.3.

To comparing the energy and cost effectiveness of discussed evaporative cooling systems with efficiency of at present widely used refrigerant vapor compression air-conditioning systems, a special research was accomplished. The constructive and operative scheme of the system operating by the heat pump cycle in winter and refrigeration

cycle in summer regime is represented in Fig.10 and air treatment processes for summer regime is shown on the air chart Fig.11.

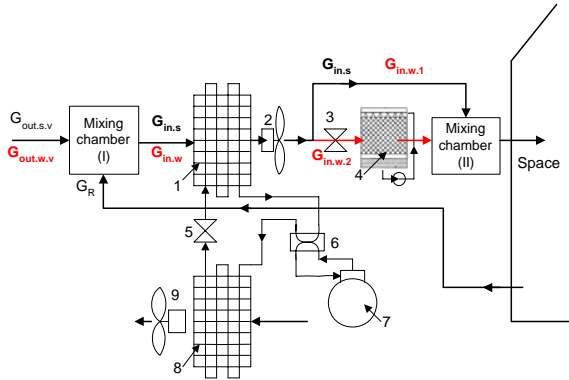

Fig. 10: air-conditioning system operating by the heat pump cycle in winter and refrigeration cycle in summer  
 1- evaporator coil in summer season and condenser in winter season ; 2, and 9- fans; 3, and 5- dampers; 4- humidifier; 6- reverse valve; 7- compressor; 8- condenser in summer season and evaporator coil in winter season

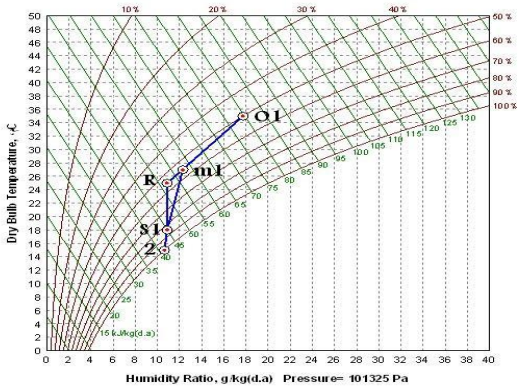

Fig. 11: Psychrometric chart for air conditioning system sourced by heat pump for summer cooling regime

The system operates both for summer cooling and winter heating in the following way:

1. Summer cooling regime

The outside ventilation air flow  $G_{out.s.v}$ , kg/sec having parameters  $t_{out.s}$  and relative humidity  $\phi_{out.s}$  enters into the mixing chamber (I) and is mixed with the air  $G_R$ , kg/sec exhausted from the served house. Then the mixture  $G_{in.s}$ , kg/sec passes through the evaporator (1), where it is cooled up to a temperature  $t_{s1}$  (process “m1-S1” Fig.11). Then the cooled mixture (point “S1”, Fig.11) by the help of fan (2) is supplied by the by-pass duct into the house where absorbing excessive heat from the inside space is heated up to required in the house temperature  $t_R$ , °C (process “S1-R” Fig.11). In summer regime the damper (3) is closed as there is not need in the humidifier (4). The condenser (8) is cooled by the outside air.

2. Winter heating regime

The described air-conditioning system operating as a heat pump is fulfilled analogically as for previous systems by the processes of air treatment shown in the Fig.3. The difference is that the gas heater is replaced by the condenser (1) of the heat pump therefore, the process “m-C” (see Fig.3) of the heating of the mixture takes place in the condenser (1). The required electric power  $N_{HP}$ , kW of the heat pump is determined by the following fraction:

$$N_{HP} = Q_{hd} / \mu \tag{9}$$

where:  $\mu$  - COP of the heat pump which for examined climatic conditions and R-22 makes  $\mu=4-4,5$

III. DEVELOPING OF THE OPTIMIZATION MATHEMATICAL MODELS FOR SUGGESTED EVAPORATIVE COOLING AIR CONDITIONING SYSTEM AND EFFICIENCY ANALYSIS

Because of maximum possible elimination of heat wastes and application of principles of internal regeneration of energy, all developed above constructions of different types of evaporative cooling air conditioning systems are energy efficient. But, for revealing the cost effectiveness of them special research was carried out based on mathematical models by the help of which the optimal design parameters can be established, which allows also to providing the least cost of air conditioning and heating. As a consequence of the comparison of possible minimum energy costs provided by each optimized system, the best one can be identified and recommended for implementation. The optimized option of each system for given conditions provides the possible minimum cost of produced and consumed energy, referred to 1 sq.m of living surface of the given building. As in this suggested method the consumers of energy, such as buildings, are considered as parts of energy system, therefore, this concept takes into account the influence of building characteristics too on the energy cost. The models include all equations representing interconnections among system's parameters and their variations' limits. The final goals of models are the adequate simulations of all important features of given system and representation of main interconnections of processes, taking place in the system.

The economical function of the model showing the cost effectiveness of the system is evaluated by the help of the value of annual estimated expenditures, referred to 1m<sup>2</sup> of floor of the house:

$$T_S = \frac{T}{S}, \tag{10}$$

where:  $T_S$  – annual total expenditures on heating and cooling (cost of energy), referred to 1m<sup>2</sup> of served house, \$/ m<sup>2</sup>,  $T$  – annual expenditures for energy production and consumption, \$/year,  $S$  – surface of building, m<sup>2</sup>.

The annual total expenditures  $T$ , \$/year for energy production and consumption includes all initial construction costs and annual operational cost of a system. In general it is

determined by the following formula:

$$T = \frac{\sum K}{Y} + U \quad (11)$$

where:  $\sum K$  – total capital investments into the construction of a system, (initial cost) \$,

$Y$  – expected pay back period of initial construction costs, year,

$U$  – total annual operational cost of the system, \$/year.

The initial cost,  $\sum K$ , \$ and total annual operational cost,  $U$ , \$/year are dependent on variable design characteristics of the systems which are conditioned by variable values of input information.

Total Capital Cost of evaporative cooling and heating system  $\sum K$ , \$ is the following sum of main equipment:

$$\sum K = K_{hum.} + K_{ducts} + K_{gas.heat.} + K_{HE} + K_{mix.ch.} + K_{fan.} + K_{fan.coils} + K_{des.wheel} + K_{ins.} \quad (12)$$

Where:  $K_{hum.}$  – initial cost of air humidifiers, \$,  $K_{ducts.}$  – initial cost of air ducts, \$,  $K_{gas.heat.}$  – initial cost of gas heater, \$,  $K_{HE}$  – initial cost of heat exchangers, \$,  $K_{mix.ch.}$  – initial cost of air mixing chambers, \$,

$K_{fan}$  – initial cost of fans, \$,  $K_{fan-coils}$  – initial cost of fan-coils, \$,  $K_{des.wheel}$  – initial cost of desiccant wheels, \$,  $K_{ins}$  – cost of insulation of building envelope constructions, \$.

Each component of mentioned capital cost should be represented in the model of the system by a formula which reflects the variation of input conditions.

The following equations are suggested for determining the initial costs of the equipment [4]:

$$K_{hum} = 26.64 + 2187V_{pad} + 632V_{pad}^2 \quad (13)$$

where;  $V_{pad}$  – volume of pad of humidifier determined by the help of mathematical model[7].

$$K_{HE} = C_{HE} F_{HE}, \quad (14)$$

where  $C_{HE}$  = 20 \$/m<sup>2</sup> – average market cost of 1m<sup>2</sup> of air to air type of heat exchangers,  $F_{HE}$  – required heat transfer surface of air to air heat exchanger, m<sup>2</sup>.

The heat transfer surface of a heat exchanger  $F_{HE}$  is calculated by the help of heat transfer equation:

$$F_{HE} = \frac{Q}{k_{HE} \Delta t_{av.HE}} \quad (15)$$

where:  $Q$  – quantity of heat transferred from heating air to the heated air, kW,  $k_{HE}$  – heat transfer coefficient of heat exchanger, W/m<sup>2</sup>°C,  $\Delta t_{av.HE}$  – average logarithmic temperature difference of heating and heated airs, °C.:

$$\Delta t_{av.HE} = \frac{(t_{air.1} - t_{air.h.2}) - (t_{air.2} - t_{air.h.1})}{\ln \frac{(t_{air.1} - t_{air.h.2})}{(t_{air.2} - t_{air.h.1})}} \quad (16)$$

where:  $t_{air.1}$  and  $t_{air.2}$  – inlet and outlet temperatures of heating air, °C,

$t_{air.h.1}$  and  $t_{air.h.2}$  – inlet and outlet temperatures of heated air, °C,

$$K_{fan-coils} = C_{fan-coils} F_{fan-coils} \quad (17)$$

where:  $F_{fan-coils}$  – heating surface of fan-coils, m<sup>2</sup>,  
 $C_{fan-coil}$  – average cost of 1m<sup>2</sup> of fan-coils, \$/m<sup>2</sup>.

$$F_{fan-coil} = \frac{Q_{hd}}{k_{fan-coil} \Delta t_{fan-coil}} \quad (18)$$

where:  $Q_{hd}$  – heading demand of the served house, kW,  $k_{fan-coil}$  – heat transfer coefficient of fan-coils, W/m<sup>2</sup>°C,  $\Delta t_{fan-coil}$  – average logarithmic difference of temperatures in fan-coils, °C.

$$\Delta t_{fan-coil} = \frac{(t_{w.1} - t_{in}) - (t_{w.2} - t_{in.hot})}{\ln \frac{(t_{w.1} - t_{in})}{(t_{w.2} - t_{in.hot})}} \quad (19)$$

where:  $t_{w.1}$  and  $t_{w.2}$  – fan-coil's inlet and outlet heating water temperatures,

$t_{in}$  and  $t_{in.hot}$  – inside air and heated in the fan – coils hot air temperatures, °C.

The following equations are suggested for determining the initial costs of the fan and water pump [5]:

$$K_{fan} = (21.5644 + 20.1554E_{fan}^{0.5})^2 \quad (20)$$

where:  $E_{fan}$  – power of fan, kW.

$$K_{pump} = \left( 16.9049 + 556.444 \left( m_w \right)^{0.5} \right) \quad (21)$$

where:  $m_w$  – mass flow of water sprayed in the humidifier, kg/sec.

$$K_{gas.heat} = \frac{C_{gas.heat} Q_{gasheat}}{\eta_{gasheat}} \quad (22)$$

where:  $C_{gas.heat}$  = 80 \$/kW – average market specific cost of 1 kW of thermal capacity of gas heaters,

$Q_{gas.heat}$  – required thermal capacity of the gas heater, kW,  $\eta_{gas.heat}$  – COP of the gas heater.

The following equation is suggested for determining the initial costs of the desiccant wheel [6]:

$$K_{des.wheel} = 25477.7V_{des.wheel} \quad (23)$$

where:  $V_{des.wheel}$  – volume of desiccant wheel,  $m^3$ .

$$K_{ins.} = C_{ins} F_{ins} \quad (24)$$

where:  $C_{ins} = 71.43\delta_{ins}$  - cost of 1m<sup>2</sup> of insulation of house constructions depending on the thickness of insulation layer  $\delta_{ins}$ , m,  $F_{ins}$  - total surface of external walls and ceiling of the house, m<sup>2</sup>.

Total annual operational cost U, \$/year of a system in general consists of the following expenditures:

$$U = U_{rep.} + U_S + U_{gas} + U_{el.} \quad (25)$$

where:  $U_{rep.}$  – system's current repair and maintenance annual bill, \$/year,

$U_S$  – annual salary of operators of the systems, \$/year,

$U_{gas}$  – cost of fuel annually consumed in the system, \$/year,

$U_{el.}$  - cost of electricity annually consumed in the system, \$/year.

The following equations are suggested for determining the annual operational cost of the system:

$$U_{rep} = R_{rep}\Sigma K, \quad (26)$$

where:  $R_{rep}$  – factor of annual repair, that usually is taken equal to 0,08 to 0,1.

$$U_S = R_S N, \quad (27)$$

where:  $R_S$  – factor of annual salary, that can be taken equal to 2 to 5 \$/kW per year.

$N$  - installed power or cooling capacity of whole evaporative cooling air conditioning system, kW.

$$U_{gas} = C_{gas} B_{gas} \quad (28)$$

where:  $C_{gas}$  – cost of unit of gas, \$/m<sup>3</sup>

$B_{gas}$  – seasonal or annual consumption of gas by energy generators, m<sup>3</sup>/year,

The value of seasonal or annual consumption of fuel  $B$  depends on the type of energy generator and for heat generators (boiler, gas heaters, etc.) can be determined by the following formula:

$$B_{gas} = \frac{Q_{seas}}{\eta_b Q_{gas}} \quad (29)$$

where:  $Q_{seas}$  – seasonal/annual heat consumption by the gas heater for desiccant reactivation and winter heating, kWh;  $\eta_b$  – gas heater COP;  $Q_{gas}$  – heating capacity of gas (for natural gas  $Q_{gas}=9,3 \text{ kWh/m}^3$ )

$$U_{el} = C_{el} E_{seas} \quad (30)$$

where:  $C_{el}$  – tariff for electricity, \$/kWh;

$E_{seas}$  – total seasonal or annual consumption of electricity by the heat pump, fans and pumps, kWh/seas.

The cost of heat pump unit  $K_{HP}$ , \$, is determined by the following production [6]:

$$K_{HP} = 350N_{HP} \quad (31)$$

The pay-back period Y of initial (capital) cost for all the examined systems is assumed Y=20 year.

The complex of all equations for determining the constructive, energy and economic characteristics represents the mathematical model of evaporative cooling and heating system of a house. The model allows optimizing the systems. For this purpose a part of input data are taken variable as a result of which the output data, particularly the cost of energy referred to 1m<sup>2</sup> of house is variable too. The least value of the cost of energy referred to 1m<sup>2</sup> of the house corresponds to the optimal option of the system including the house insulation rate. All design parameters providing the optimal option are the optimal. Programs of calculations were composed in C++ language.

By the help of the results of computer aided calculations the possible least costs  $T_s$ , \$/m<sup>2</sup> for

#### IV. Results and Dissection

evaporative cooling and heating of a family house located in different climatic conditions were revealed which are represented by diagrams in figures below:

##### A. The Direct Evaporative Air conditioning – Heating System

The system is analyzed for climatic conditions of Saudi Arabia, City Abha  $t_{out,summer} = 30.5 \text{ }^\circ\text{C}$ ,  $t_{out,winter} = 5.2 \text{ }^\circ\text{C}$  and  $\phi_{out} = 14.5 \%$ , required inside parameters:  $t_{in} = 25 \text{ }^\circ\text{C}$ ,  $\phi_{in} = 50 \%$  [2]. The effectiveness of the humidifier and air gas heater were assumed 90 % and 85%, respectively. The COP of pumps are assumed 85 % and of fans 75 %. The least costs  $T_s$ , \$/m<sup>2</sup> depending on the various thicknesses  $\delta_{ins}$ , m are represented by diagrams on the Fig. 12. From the Fig. 12 can be seen that the produced by this system energy cost is the minimum in case of thickness of insulation layer equal to  $\delta_{ins} = 0,1\text{m}$ . For the heat pump system the energy minimum specific cost occurs in case of insulation layer equal to  $\delta_{ins} = 0,22\text{m}$ . The comparison shows that energy minimum specific cost provided by the direct evaporative air conditioning – heating system makes  $T_s=3,2\$/\text{m}^2$  per year and by the heat pump system makes  $T_s = 7,5 \$/\text{m}^2$  per year i.e. the energy cost provided by direct evaporative air conditioning – heating system is 2,34 times cheaper.

##### B. The Indirect Evaporative Air conditioning-heating System with preliminary cooling of outside air

The system is analyzed for climatic conditions of Saudi Arabia, City Al Madinah  $t_{out,summer} = 44,8 \text{ }^\circ\text{C}$ ,  $t_{out,winter} = 8,8 \text{ }^\circ\text{C}$  and  $\phi_{out} = 5,8 \%$ , required inside parameters:  $t_{in} = 25 \text{ }^\circ\text{C}$ ,  $\phi_{in} = 50 \%$  [2]. The effectiveness of the humidifier and air gas heater were assumed 90 % and 85%, respectively. The COP of pumps are assumed 85 % and of fans 75 %. The least



costs  $T_s$ ,  $\$/m^2$  depending on the various thicknesses  $\delta_{ins}$ , m are represented by diagrams on the Fig. 13. From the Fig. 13 is clear that the produced by this system energy cost is the minimum in case of thickness of insulation layer equal to  $\delta_{ins} = 0,15m$ . For the heat pump system the energy minimum specific cost occurs in case of insulation layer equal to  $\delta_{ins} = 0,3m$ . The comparison shows that energy minimum specific cost provided by the indirect evaporative air conditioning – heating system makes  $T_s=4,0$   $\$/m^2$  per year and by the heat pump system makes  $T_s = 11,0$   $\$/m^2$  per year i.e. the energy cost provided by indirect evaporative air conditioning – heating system is 2,75 times cheaper.

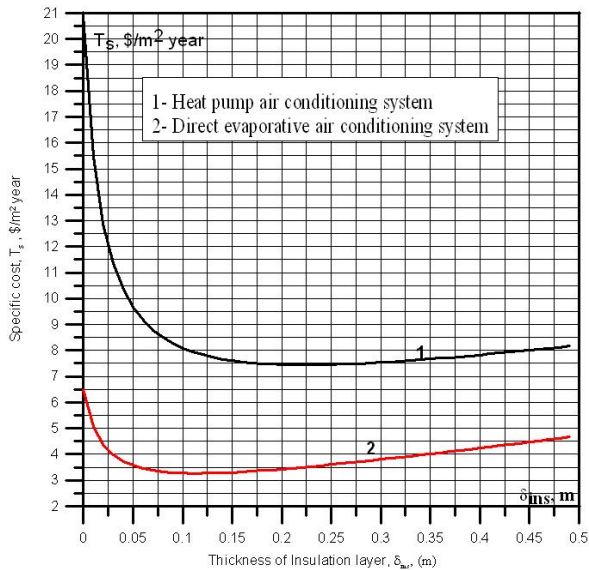

Fig.12. Specific costs  $T_s$ ,  $\$/m^2$  per year, for direct ECAC-heating system for conditions of Saudi Arabia, city Abha depending on the thickness  $\delta_{ins}$ , m of the building envelope.

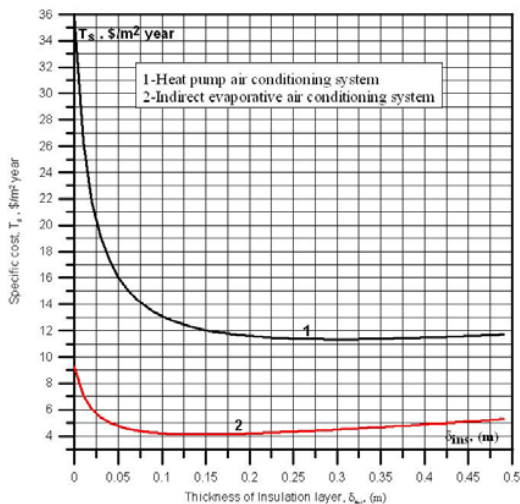

Fig.13. Specific costs  $T_s$ ,  $\$/m^2$  per year, for indirect ECAC-heating system for climatic conditions of Saudi Arabia, city Madinah depending on the thickness  $\delta_{ins}$ , m of the building

### C. The Evaporative cooling Air conditioning - heating System with one stage of preliminary drying of the outside air (one desiccant wheel)

The system is analyzed for climatic conditions of Egypt, City Aswan  $t_{out,summer} = 42.6$   $^{\circ}C$ ,  $t_{out,winter} = 9.1$   $^{\circ}C$  and  $\varphi_{out,s} = 18$  %, and required inside parameters:  $t_{in} = 25$   $^{\circ}C$ ,  $\varphi_{in} = 50$  % [2]. The mathematical model and software for determining desiccant wheel's design parameters was developed by the authors of this paper [3]. The least costs  $T_s$ ,  $\$/m^2$  depending on the various thicknesses  $\delta_{ins}$ , m are represented by diagrams on the Fig. 14. The Fig. 14 shows that the produced by this system energy cost is the minimum in case of thickness of insulation layer equal to  $\delta_{ins} = 0,2m$ . For the heat pump system the energy minimum specific cost occurs in case of insulation layer equal to  $\delta_{ins} = 0,3m$ . The comparison shows that energy minimum specific cost provided by the evaporative air conditioning system with one stage of preliminary drying of the outside air makes  $T_s=6,0$   $\$/m^2$  per year and by the heat pump system makes  $T_s = 10,7$   $\$/m^2$  per year i.e. the energy cost provided by evaporative air conditioning – heating system with one stage of drying is 1,78 times cheaper.

### D. The Evaporative cooling Air conditioning - heating System with two stage of preliminary drying of the outside air (two desiccant wheel)

The system is analyzed for climatic conditions of Egypt, City Cairo  $t_{out,summer} = 35$   $^{\circ}C$ ,  $t_{out,winter} = 8$   $^{\circ}C$  and  $\varphi_{out,s} = 50$  %, and  $t_{in} = 25$   $^{\circ}C$ ,  $\varphi_{in} = 55$  % [2]. The least costs  $T_s$ ,  $\$/m^2$  depending on the various thicknesses  $\delta_{ins}$ , m are represented by diagrams on the Fig. 15 from which can be seen that the produced by this system energy cost is the minimum in case of thickness of insulation layer equal to  $\delta_{ins} = 0,2m$ . For the heat pump system the energy minimum specific cost occurs in case of insulation layer equal to  $\delta_{ins} = 0,3m$ . The comparison shows that energy minimum specific cost provided by the evaporative air conditioning system with one stage of preliminary drying of the outside air makes  $T_s=6,0$   $\$/m^2$  per year and by the heat pump system makes  $T_s = 9,0$   $\$/m^2$  per year i.e. the energy cost provided by evaporative air conditioning – heating system with two stages of drying is 1,5 times cheaper.

The figure 15 shows also that the specific cost of desiccant system increases with increase of reactivation air temperature. If the reactivation air temperature exceeds  $100$   $^{\circ}C$  the desiccant system is less efficient, than the heat pump system.

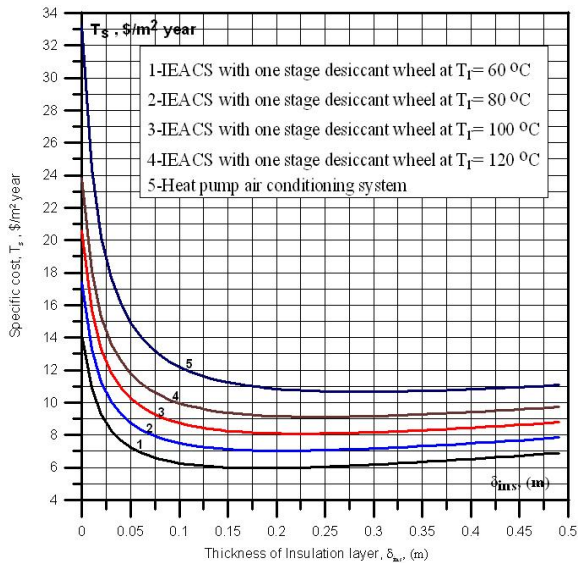

Fig. 14. Specific costs  $T_s, \$/m^2$  per year, for IEACS with one stage of desiccant wheel system for conditions of Egypt, city Aswan depending on the thickness  $\delta_{ins}$ , m of the building envelope.

## REFERENCES

- [1] A.Fouda, Z, Melikyan, A Method for Determining the Cooling Load of Residential Buildings, 4<sup>th</sup> international renewable and clean energy conference and exhibition, Armenia Yerevan, October 5-7, 2009.
- [2] ASHRAE Fundamentals Handbook, USA, 2001.
- [3] Z, Melikyan, A.Fouda. Air Conditioning Systems: Calculating Desiccant Wheels' Design Parameters, Encyclopedia of Energy Engineering and Technology, 2010.
- [4] <http://www.kennspenns.com/coolerparts>
- [5] J.R. Camargo, C.D. Ebinuma and J.L. Silveira Thermoeconomic analysis of an evaporative desiccant air conditioning system, Applied Thermal Engineering 23 (2003) pp.1537–1549.
- [6] K. Ghali, Energy savings potential of a hybrid desiccant dehumidification air conditioning system in Beirut, Energy Conversion and Management 49 (2008) pp-3387–3390.
- [7] A.Fouda, Z, Melikyan, A simplified model for analysis of heat and mass transfer in a direct evaporative cooler, 7<sup>th</sup> International Engineering Conference, Egypt, Mansoura - Sharm ElSheik March 23–28, 2010.

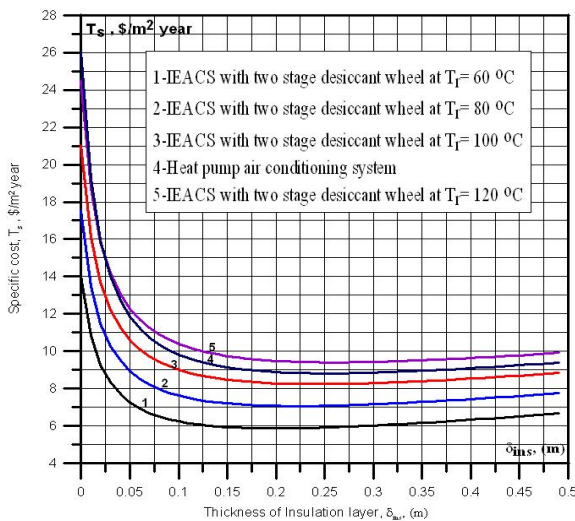

Fig. 15. Specific costs  $T_s, \$/m^2$  per year, for IEACS with two stage of desiccant wheel system for the conditions of Egypt, city Cairo depending on the thickness  $\delta_{ins}$ , m of the building envelope.

## V. CONCLUSION

1. The implementation of suggested evaporative cooling-heating air conditioning systems in proper climatic conditions will provide a significant saving of natural gas.
2. Correctly designed and properly optimized all types of evaporative cooling – heating air conditioning systems in many climatic conditions are more cost effective, than even heat pump heating cooling systems.