

Modeling and Simulation of Photovoltaic based LED Lighting System

Ankit R Patel, Ankit A Patel, Mahesh A Patel, and Dhaval R Vyas

Abstract—Although lighting systems powered by Photovoltaic (PV) cells have existed for many years, they are not widely used, especially in lighting for buildings, due to their high initial cost and low conversion efficiency. One of the technical challenges facing PV powered lighting systems has been how to use dc power generated by the PV module to energize common light sources that are designed to operate efficiently under ac power. Usually, the efficiency of the dc light sources is very poor compared to ac light sources. Rapid developments in LED lighting systems have made this technology a potential candidate for PV powered lighting systems. This study analyzed the efficiency of each component of PV powered lighting systems to identify optimum system configurations for different applications.

Keywords—Energy Efficiency, LED, Modeling of systems, Photovoltaic.

I. INTRODUCTION

PHOTOVOLTAIC Cell converts sunlight into electricity and produce direct current (dc), which can be used for energizing various devices. Lighting is one way to use this solar generated electricity. Some examples of PV powered lighting systems are decorative pathway makers and residential garden lights, portable highway signs, and off-grid, rural area light fixtures. However, PV powered lighting systems are not widely used, due to their high initial cost, low system efficiency, and poor reliability. One reason for the low system efficiency is that the dc produced by the PV cells has to be converted to ac using an inverter in order to power the light source. Although there are light sources that can be operated off dc, they generally have very poor efficiency. Light Emitting Diode (LED) Technology has been advancing rapidly over the past several years[1]. Some of the white LEDs in the marketplace have efficacies exceeding 25 lm/W including the driver losses, which is twice the efficacy of the residential incandescent lamp and may be up to five times greater than that of a dc powered incandescent light source [2]. Therefore, white LED technology is a candidate for creating

efficient PV powered lighting systems.

The goal of the study described in this paper was to analyze the different components of PV powered lighting systems, to estimate the whole system efficiency, to understand what affects system efficiencies, and to identify optimum system configurations for various applications. The light sources considered were halogen lamps, Compact Fluorescent Lamps (CFLs), Linear Fluorescent Lamps (LFLs), and LED Lamps. The information required for this analysis was gathered from literature and laboratory measurements. An experiment was conducted to evaluate the efficiency of a hybrid power conditioning unit used in PV powered lighting systems.

A literature survey was conducted to understand what types of lighting system configurations exist for PV operation, the performance of each of these configurations, and how efficient each of the components is. Components typically used in a PV powered lighting system may include a PV cell (or PV panel), battery, electricity grid, power conditioning unit (to provide dc output), ac load center (to provide ac output), dc-to-dc converter, ac-to-dc converter (LED ac driver), dc current regulator, and light sources, as well as luminaire. Depending on the light source and the different application requirements, the system configuration may include only some of these components.

Three major types of system configuration exist for PV powered lighting systems. These include the standalone system, the utility connected system, and the hybrid system [3][4]. Standalone systems are mostly seen in residential pathway markers, parking lot luminaire, and off-grid facility lighting systems. They normally require batteries, which introduce high storage-retrieval losses and high maintenance costs [5]. Utility connected systems do not require batteries; instead they are connected to an electrical grid and draw power from the grid when the solar power connected from the PV panels is not sufficient for the intended application. Depending on the type of load, a power conditioning unit or an ac load centre is needed in utility connected systems to mix the input power from the utility grid. Optionally, some utility connected systems can feed power back to the grid when the PV panels generate more energy than needed. Hybrid systems combine a number of electricity production and storage elements to meet the energy demand—for example, a utility connected system with a battery backup. These systems are complicated and expensive but are more reliable, especially when connected to a utility grid.

The literature indicates that the conversion efficiency of a

Ankit R Patel is PG Student with the Department of Electrical Engineering, VJTI, Mumbai, India (majorankit@gmail.com)

Ankit A Patel is Lecturer with the Department of Electrical Engineering, Institute of Diploma Studies, Nirma University, Ahmedabad, India (ankit10882@yahoo.com)

Mahesh A Patel is Assistant Professor with the Department of Electrical Engineering, LCIT, Bhandu, Mahesana, India (mahesh21k@yahoo.com)

Dhaval R Vyas is PG Student with the Department of Electrical Engineering, NIT Kurukshetra, India (dhavalforever@gmail.com)

state-of-the-art GaInP/GaAs/Ge PV cell can be up to 35%, Efficiency for a commercially available PV module is 15%, the LED ac driver efficiency is 80% [9], the LAD current regulator efficiency is 85% [10][11], and the dc-ac inverter efficiency is 80% [12]. The luminaire efficiency is typically 85% for an LED luminaire [13], 80% for a halogen luminaire [14], 60% for a CFL luminaire in a directional lighting application [15], and 70% for a LFL luminaire in a directional lighting application [16][17]. In directional lighting applications, CFLs and LFLs have lower luminaire efficiencies because the large sizes of these light sources cause difficulty in optical control. In general lighting applications, CFLs and LFLs have higher luminaire efficiencies. It is estimated that the luminaire efficiency in a general lighting application is typically 70% for a CFL luminaire and 80% for a LFL luminaire. The efficiency of an ac load centre is estimated to be 90%.

II. EXPERIMENT

The efficiency of a grid connected hybrid power conditioning unit, which outputs dc power with the both ac(grid) and dc(PV) input powers, was evaluated through an experiment. The power conditioning unit draws power from the ac grid when the amount of dc power collected from the PV panels is not sufficient to meet the needs of the lighting system [18].

During the day, the solar energy reaching the PV panels changes significantly, and as a result, the dc power generated by the PV panels also changes. When the power is not sufficient to meet the needs of the lighting system, additional power is drawn from the electrical grid of the building to maintain constant light output. When the amount of dc input power varies, the efficiency of the power conditioning unit may also change. The efficiency is defined as the ratio of the output power to the input power:

$$\eta_{\text{cond}} = \text{Output Power} / \text{Input Power} \quad (1)$$

The power conditioning unit used in this study has a capacity of 720W input and 660W output. The requirements for the input power are 208V ac and at least 28V for the dc; for the output power, the requirement is 26.6V. In this study, a dc power supply was used to mimic the PV power source.

III. MODELING AND SIMULATION

The system configuration used in this experiment (see Fig.1) includes the following components: the power conditioning unit, 208V ac power from the grid, a dc power supply(simulating the power collected from PV panels), a dc current regulator, and an LED lighting system with high-flux white LEDs. This setup simulates a utility connected PV powered LED lighting system in buildings (see Fig.2).

Since the power conditioning unit output power capacity is relatively high, a series resistor was added to the LED lighting system to get to about 80% of its capacity. The power

dissipated by the LED lighting system is approximately 20W, and in the resistor is about 520W. Please note that this resistive load is not necessary in a full-scale installation. The input power from the dc power supply, the input power from the 208V ac grid, the output power for the LED lighting and the resistive load, and the relative light output of the LED lighting system were monitored and recorded. A photo sensor was used to record the relative light output of the LED lighting system.

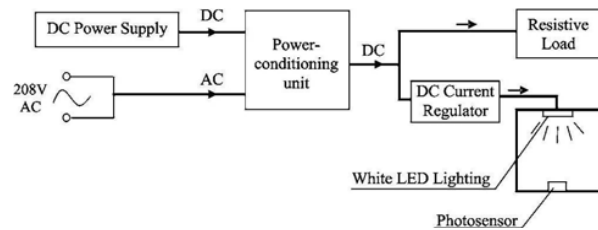

Fig.1 Schematic Diagram of the experimental setup

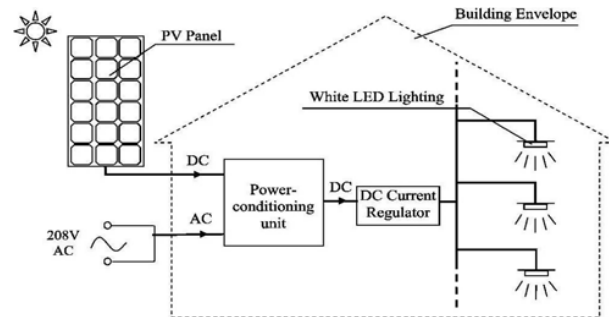

Fig.2 Simulation of PV Powered Lighting systems in buildings

The different dc input power levels were achieved by setting different output current levels while maintaining a constant voltage from the dc power supply. The input power from the dc power supply, the input power from the 208V ac grid, and the total output power were measured. The efficiency of the power conditioning unit under different dc input power levels was calculated by taking the ratio of the total output power to the input power. The relative light output of the white LED lighting was monitored by a photo sensor under varied dc input power levels.

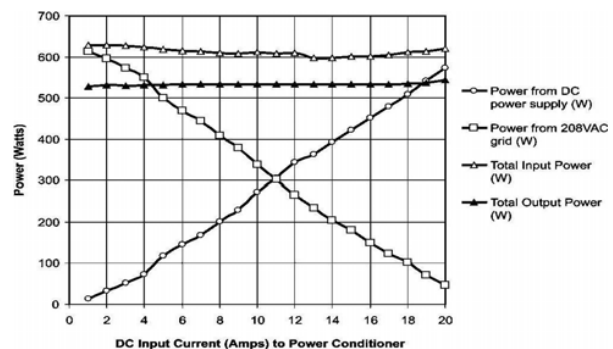

Fig.3 Hybrid Power Conditioning System: I/P and O/P Power Analysis

Figure 3 shows the input power from the dc power supply, the 208V ac grid power, and the output power for the different current settings of the power supply. As seen, when input dc power decreases, the ac power drawn from the grid increases. The output power remained constant for various dc input power levels, with a maximum-to-minimum difference of 2.6%. The total input power (sum of dc and ac) also remained fairly stable, with a maximum-to-minimum difference of 5.3%.

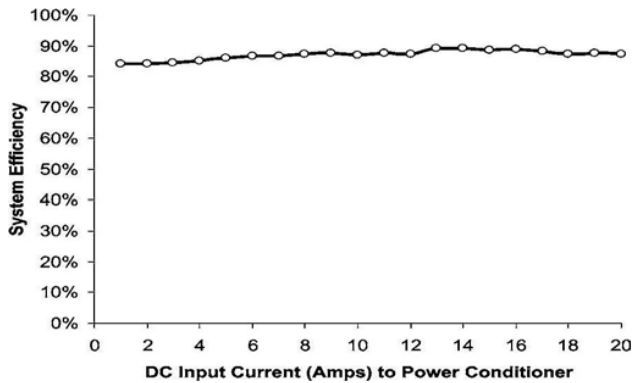

Fig.4 Hybrid Power Conditioning System: Efficiency at different current levels

Figure 4 shows the efficiency of the power conditioning unit as a function of dc input current. We see that the system efficiency is slightly higher when the dc input power is high, the maximum to minimum difference is 6.1%. The average system efficiency across different dc input power levels is 87.1%.

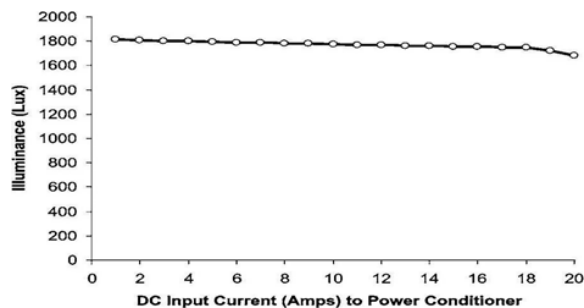

Fig.5. Relative light output of the white LED lighting system

Figure 5 shows the relative light output of the white LED lighting system as a function of dc input power. The photo sensor was placed 1ft. (30 cm) away from the light source. As seen, the relative light output of the white LED lighting system drops slightly with increased dc power, and the maximum-to-minimum difference is 7.7%. This means the light output of an LED lighting system could change up to 7.7% in a real life system. In most lighting applications, this amount of change will be hardly perceivable [19].

IV. ESTIMATING OVERALL SYSTEM EFFICIENCY

The formula below was used to estimate the overall system efficacy for PV powered lighting systems:

$$E = \eta_{PV} \eta_{bat} \eta_{cond} \eta_{ac} \eta_{inv} \eta_{reg} \eta_{src} \eta_{lum} \quad (2)$$

where,

η_{PV} = PV panel efficiency, assume = 15%

η_{bat} = Battery efficiency, assume = 80%

(η_{bat} = 100% if not including batteries in systems)

η_{cond} = Power conditioning unit efficiency based on experiment is = 87%

(η_{cond} = 100% if not including power conditioning unit in systems)

η_{ac} = AC load centre efficiency, assume = 90%

(η_{ac} = 100% if not including into systems)

η_{inv} = DC-AC inverter efficiency

(η_{inv} = 100% if light source is LED or Incandescent or Halogen)

η_{reg} = DC current regulator efficiency

(η_{reg} = 100% if light source is not LED)

η_{src} = Efficiency of light source (lm/W)

η_{lum} = Luminaire efficiency

Examples are given below for calculating overall system efficacies of PV powered lighting systems. For example, assume we have a utility-connected PV powered lighting system that uses white LED as the light source, and a hybrid power conditioning unit that is the same as the one previously tested to connect to the electricity grid. The system efficacy for such a lighting system in directional lighting applications, expressed as lm/W of solar energy that arrives at the PV panels, can be calculated as:

$$E_{utility-connected LED} = \eta_{PV} \eta_{bat} \eta_{cond} \eta_{ac} \eta_{inv} \eta_{reg} E_{src} \eta_{lum} = 2.4 \text{ lm / W} \quad (3)$$

For comparison, if the lighting system uses a CFL as the light source, it does not need a dc current regulator, but it does need a dc-to-ac inverter. Also, since a CFL uses ac power, this lighting system does not need a power conditioning unit that provides dc power; instead it needs an ac load centre to mix the ac power inverted from the dc and ac power from the grid. The system efficacy can be calculated as:

$$E_{utility-connected CFL} = \eta_{PV} \eta_{bat} \eta_{cond} \eta_{ac} \eta_{inv} \eta_{reg} E_{src} \eta_{lum} = 4.1 \text{ lm / W} \quad (4)$$

Note that these efficacy values were calculated for every solar watt that arrives at the PV panels. In contrast to a PV powered lighting system, if the light source is directly and completely energized by ac grid power, the efficacy values can be calculated for every watt for ac grid, as shown below for ac powered white LED:

$$E_{ac powered LED} = \eta_{AC driver} \eta_{Lamp} \eta_{Luminaire} = 17.0 \text{ lm / W} \quad (5)$$

Using similar calculations, we obtained the results found in table 1, which summarizes the system efficacy (lm/W) for

different configurations of PV powered lighting systems in directional lighting applications (ac powered system are also included for reference).

TABLE I
SYSTEM EFFICACY FOR DIFFERENT SYSTEM CONFIGURATION FOR DIRECTIONAL LIGHTING APPLICATIONS

System Configuration	Efficacy (lm/W)			
	DC Light Source		AC Light Source	
	White LED	Halogen	CFL	LFL
AC-Powered	17.0	16.0	39.0	60.0
Standalone (PV+Battery)	2.2	1.9	3.7	5.7
Utility-connected (PV+Grid, No Battery)	2.4	2.1	4.2	6.4
Hybrid (PV+Grid+Battery)	Depends on the proportion of usage between grid and battery			

As we can see from the table the system efficacy of PV powered LED lighting systems using white LEDs as the light source is higher than those using Halogen lamps, but is still not as high as those using CFL and LFL. The main systems, the efficacy of white LED lamps needs to be reason for this difference is that the luminous efficacy of white LED lamp is still not high enough, currently at 25 lm/W. In order to complete with other light sources in PV powered lighting systems for directional lighting applications, the luminous efficacy of white LED lamps must reach the values listed in table 2.

TABLE II
TARGET WHITE LED EFFICACY TO COMPARE WITH OTHER LIGHT SOURCES

Syst. Confi.	Target Efficacy (lm/W)		
	Halogen	CFL	LFL
Ac-powered	24	57	88
Standalone (PV+Battery)	22	43	66
Utility-connected (PV+Grid, No Battery)	22	45	68

As shown in table2, for ac powered lighting systems, the efficacy of white LED lamps needs to be at least 57 lm/W in order to complete with CFL, and 88 lm/W to compare with LFL. White LED lamps are far less competitive than fluorescent lamps in ac powered lighting applications. In standalone PV powered lighting systems, the efficacy of white LED lamps needs to be at least 43 lm/W in order to compete with CFL, and 66 lm/W to compete with LFL. In utility connected PV powered lighting systems, the efficacy of white LED lamps needs to be at least 45 lm/W in order to compete with CFL, and 68 lm/W to compete with LFL. In all the lighting systems we have discussed, using white LEDs is already more efficacious than using halogen lamps.

The preceding calculations and results assume that PV powered lighting systems are used in directional lighting applications. If they are used in general lighting applications, the estimated overall system efficacies will be higher for CFL

and LFL, because their luminaries have higher efficiencies in general lighting applications.

In order to compete with other light sources in general lighting applications, the luminous efficacy of white LED lamps must reach the values listed in table III.

TABLE III
TARGET WHITE LED EFFICACY TO COMPARE WITH OTHER LIGHT SOURCES IN PV POWERED LIGHTING SYSTEMS FOR GENERAL LIGHTING APPLICATIONS

Syst. Confi.	Target Efficacy (lm/W)		
	Halogen	CFL	LFL
Ac-powered	24	67	100
Standalone (PV+Battery)	22	50	75
Utility-connected (PV+Grid, No Battery)	22	52	78

V. CONCLUSION

The system efficacy of white LED lamps in either directional lighting applications or general applications still is not competitive enough to be used in PV powered lighting systems for buildings. But with the rapid development of LED technology, LED light sources have the potential to become the preferred light source for PV powered lighting systems for buildings in the near future. Recent white LED technology has shown an efficacy of more than 40 lm/W [20], very close to becoming more efficacious than CFL in PV powered directional lighting applications.

ACKNOWLEDGMENT

The authors gratefully acknowledge the contributions of many people from Gujarat Energy Development Agency (GEDA). Authors also very thankful to Mr. Sanjay Karnadhar, Scientist-B, Ministry of New and Renewable Energy, Government of India for his advice time to time.

REFERENCES

- [1] N. Narendran, State of LED technology, presented at LED expo 2003, Seoul, South Korea(2003)
- [2] Oaram Sylvania, Lighting, miniature incandescent lamps, Automotive Lamp Catalog, March 2009.
- [3] U.S. Department of Energy, Office of EE and RE, PV in use: getting the job done with solar electricity, 2008.
- [4] Missouri Department of Natural Resources, Missouri Solar Energy Resources, <http://www.dnr.state.mo.us/energy/renewables/solar9.htm>
- [5] Transtronics, Inc., Battery Backup Application Handbook, <http://www.xtronics.com/reference/batterap.htm>
- [6] M. Green, K. Emery, D.L. King, S. Igari and W. Warta, Solar cell efficiency tables(ver.22), Prog. Photovoltaics 11, pp. 347-352, 2003.
- [7] U.S. Department of Energy, Office of EE and RE, Get your power from the sun – a consumer's guide, <http://www.nrel.gov/docs/fy04osti/35297.pdf> (2003).
- [8] Department of Trade and Industry Sustainable Energy Programmes, UK, The use of direct current output from PV systems in buildings, HMSO, London (2002).
- [9] Philips Lighting, Xitanium™ LED power drivers-25W and 40 W LED power drivers, Advance Transformer online Catalog, <http://www.advancetransformer.com> (2009).
- [10] Supertex, Inc. HV9903 white LED driver, Online Catalog, <http://www.supertex.com/pdf/datasheets/HV9903.pdf>
- [11] Integrated Illumination Systems, Smart driver, <http://www.i2systems.com/products/smartdriver.htm> (2004).

- [12] U.S. Department of Energy, Office of EE and RE, Information Resources: inverters, <http://www.eere.energy.gov/consumerinfo/factsheets/bb8.htm> (2004).
- [13] Integrated Illumination Systems, Benefits of high brightness LED technology, <http://www.i2systems.com/services/index.htm> (2004).
- [14] Genlyte Thomas Group LLC, Calculite evolution incandescent open downlight C4MRD, Lightolier Division Catalog (2003).
- [15] Genlyte Thomas Group LLC, Calculite compact fluorescent open downlight 8022, Lightolier Division Catalog (2002).
- [16] Cooper Lighting, 2GC 22 Troffer, Metalux Catalog
- [17] Genlyte Thomas Group LLC, DEEPCEL plus DPA2G18LP332, Lightolier Division Catalog (2002).
- [18] Nextek Power Systems, Inc., NPS660 Gateway to Power, <http://www.nextek.com/library/Nextek660.pdf>
- [19] Y. Akashi and J. Neches, Detectibility and acceptability of illuminance reduction for load shedding, J. Illumination Eng. Soc. 33(1), pp.3-13, 2004.
- [20] Lighting Research Center, LEDs rapidly advancing to meet lighting needs, LRC news, <http://www.lrc.rpi.edu/resources/news/enews/Jul03/general64.html> (2003).



Dhaval R Vyas (DoB: July 18, 1985) is doing PG in Electrical Engineering (Control Systems) from NIT, Kurukshetra. He received Bachelor of Engineering Degree from L. C. Institute of Technology, Bhandu, Mahesana (Gujarat). He has authored more than 05 research papers in National/International conferences and reputed journals. He is a Life Member of ISTE, New Delhi; Member of ACEEE, Finland. Dhaval

Vyas's areas interest includes Adaptive and Robust Control, Robotics, and Intelligent Control Systems.



Ankit R Patel (DoB: January 11, 1982) is doing PG in Electrical Engineering (Control Systems) from VJTI, Mumbai. He received Bachelor of Engineering Degree from Government Engineering College, Modasa (Gujarat). Mr. Patel has extensive industrial and academic experience. He has authored more than 09 Research Papers in National/International conferences and reputed journals. He is a Life Member of ISTE, New

Delhi; PSSI, Gandhinagar; SESI, New Delhi; ISOI, Bangalore; SSI, New Delhi; Associate Member of SPE(I), Vadodara; Member of ACEEE, Finland;

IACSIT, Singapore, IAENG, Hong Kong. Ankit Patel's areas interest are Nonlinear System Analysis and Design, Modeling and Analysis of Systems and Application of Control Techniques for Power System Efficiency Improvement.



Ankit A Patel (DoB: August 10, 1982) is Lecturer in Electrical Engineering Department, Institute of

Diploma Studies, Nirma University, Ahmedabad. He received Bachelor of Engineering Degree from Government Engineering College, Modasa (Gujarat) and M.Tech in Electrical Engineering (Control Systems) from VJTI, Mumbai. Mr. Patel has extensive industrial and academic experience. He has authored 02 International Papers. He is a Life Member of ISTE, New Delhi. Ankit

Patel's areas interest includes Nonlinear Control Systems, Robotics, and Numerical Methods for Power Systems.



Mahesh A Patel (DoB: January 02, 1975) is Assistant Professor in Department of Electrical Engineering, L. C. Institute of Technology, Bhandu, Mahesana (Gujarat). He received

Bachelor of Engineering Degree from Government Engineering College, Modasa (Gujarat) and M.Tech in Electrical Engineering (Power Apparatus and Systems) from Nirma University, Ahmedabad. Mr. Patel has extensive industrial and academic experience. He has authored 04 International Papers. He is a Life Member of ISTE, New Delhi; Member of IETE, Kolkata; ACEEE, Finland; IACSIT, Singapore; IAENG, Hong Kong. Mahesh Patel's areas interest includes Plasma Science Technology and Its Applications and Modeling of Power Systems.