

Detecting Defects in Textile Fabrics with Optimal Gabor Filters

K. L. Mak, and P. Peng

Abstract—This paper investigates the problem of automated defect detection for textile fabrics and proposes a new optimal filter design method to solve this problem. Gabor Wavelet Network (GWN) is chosen as the major technique to extract the texture features from textile fabrics. Based on the features extracted, an optimal Gabor filter can be designed. In view of this optimal filter, a new semi-supervised defect detection scheme is proposed, which consists of one real-valued Gabor filter and one smoothing filter. The performance of the scheme is evaluated by using an offline test database with 78 homogeneous textile images. The test results exhibit accurate defect detection with low false alarm, thus showing the effectiveness and robustness of the proposed scheme. To evaluate the detection scheme comprehensively, a prototyped detection system is developed to conduct a real time test. The experiment results obtained confirm the efficiency and effectiveness of the proposed detection scheme.

Keywords—Defect detection, Filtering, Gabor function, Gabor wavelet networks, Textile fabrics.

I. INTRODUCTION

IN the textile industry, before any shipments are sent to customers, inspection is needed for assuring the fabric quality because defects in fabrics can reduce the price of a product by 45% to 65% [1]. Currently, the quality assurance of web processing is mainly carried out by manual inspection. However, the reliability of manual inspection is limited by ensuing fatigue and inattentiveness. Now only about 70% of defects can be detected by the most highly trained inspectors [2]. Furthermore, textile industries are facing increasing pressure to be more efficient and competitive by reducing costs. Therefore, automated detection of defects in textile fabrics, which results in high-quality products and high-speed production is definitely needed.

In fact the problem of automated inspection on plain fabrics has been investigated for over two decades. Wang et al. [3] contributed the success in this area to the fact that 90% of the defects in a plain fabric could be detected simply by thresholding. Therefore, in recent years, researchers have begun

to investigate the automated inspection of more complicated fabrics, including twill and denim fabrics [4, 5, 6].

Numerous approaches have been proposed to address the problem of detecting defects in woven fabrics, including statistical, spectral and model based approaches, and spectral approaches are the most successful detection approaches for woven fabrics. Since a Gabor filter has an optimal localization both in the spatial domain and in the spatial-frequency domain, it is one of the most famous spectral approaches and has been successfully and widely used in the field of defect detection. Escofet et al. [4] applied a set of multi-scale and multi-orientation Gabor filters to inspect fabric defects. Kumar and Pang [5] detected fabric defects with a set of filters, which derived from the real parts of Gabor functions from sixteen different channels in four orientations. The authors also investigated the supervised and unsupervised detection algorithms based on Gabor functions by detecting some real fabric defects in [6]. Bodnarova et al. [7] discriminated defective texture pixels from non-defective texture pixels with the proposed optimal 2-D Gabor filters, which was designed based on the Fisher cost function.

All the detection methods using Gabor functions can be classified into two categories. One is to use a filter bank, such as [4, 5] and the unsupervised method in [6], and the other one is to use optimal filters, such as [7] and the supervised method in [6]. In general, filtering with a filter bank can generate excessive data for processing though a set of filters may aid the segmentation. Correspondingly, the quality of classification and recognition is affected dramatically [8], and the time consumption is large as well. However, optimal filters can avoid the disadvantages [9], which are usually problem specific. In an optimal filter, the filter parameters are tuned to match a particular texture background. Therefore, fewer filters are needed, and the time consumed for filtering is correspondingly less.

Although optimal filters have some obvious advantages over other methods, the choice for the parameters of optimal filters is crucial and difficult. This paper presents an effective filter selection method for detecting fabric defects, which can solve the problem of filter parameter selection. In the method, Gabor wavelet networks (GWN) is used to extract texture features, which can provide some priori knowledge for the design of optimal 2-D Gabor filters. It can be noted that according to the literature, this application represents one of the fastest implementation of Gabor filter based solutions to the problem

This work was supported by the Research Grants Council of the Hong Kong Special Administrative Region under Grant HKU7382/02E.

Prof. K.L. Mak is with the Department of Industrial and Manufacturing Systems Engineering, The University of Hong Kong, HK. (phone: 852-2859-2582; fax: 852-2858-6535; e-mail: makkl@hkucc.hku.hk)

Mr. P. Peng is with Department of Industrial and Manufacturing Systems Engineering, The University of Hong Kong, HK. (e-mail: ppeng@hkusua.hku.hk).

of real-time automatic defect detection for textile fabrics. The paper is organized as follows: Section 2 gives a brief description about Gabor functions. In section 3, Gabor wavelet network is introduced. In section 4, a Gabor filter based detection scheme is described in detail. Section 5 tests and evaluates the performance of the proposed scheme. Finally, the conclusions from this work are summarized in section 6.

II. GABOR FUNCTIONS

A 2-D Gabor function is a complex exponential modulated by a Gaussian function, which can form a complete but non-orthogonal basis set. It is parameterized by four values which control the radial frequency bandwidths (σ_x, σ_y), the orientation θ and the central frequency ω_x . The impulse response is generally defined as

$$g(x', y') = \frac{1}{2\pi\sigma_x\sigma_y} e^{-\frac{1}{2}\left[\left(\frac{x'}{\sigma_x}\right)^2 + \left(\frac{y'}{\sigma_y}\right)^2\right]} \exp(j2\pi\omega_x x') \quad (1)$$

where (x', y') are the rotated (x, y) coordinates.

$$\begin{bmatrix} x' \\ y' \end{bmatrix} = \begin{bmatrix} \cos\theta & -\sin\theta \\ \sin\theta & \cos\theta \end{bmatrix} \begin{bmatrix} x \\ y \end{bmatrix} \quad (2)$$

Fig. 1 is the schematic diagram of a typical Gabor filter in the spatial domain. The real part of a Gabor wavelet is even symmetric, which is an excellent blob detector [10], and the imaginary part is odd symmetric, which performs as an edge detector [11]. In this paper, the term, an imaginary Gabor wavelet, is used to represent the imaginary part of a Gabor function to simplify the explanations.

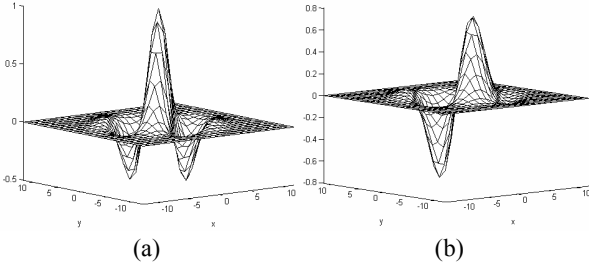

Fig. 1 Schematic diagram for the real (a) and imaginary (b) parts of a typical Gabor filter.

III. GABOR WAVELET NETWORK

On the basis of wavelet networks [12], Kruger and Sommer proposed the concept of Gabor Wavelet Networks (GWN) for solving the 2D problems in pattern recognition [13], in which an imaginary Gabor wavelet function is used as a transfer function in the hidden layer of the network. The mapping form of the network can be governed by

$$f(x, y) = \sum_{i=1}^N w_i g_o^i(x, y) + \bar{f} \quad (3)$$

where w_i is a network weight from the hidden layer to the output layer and \bar{f} is introduced to eliminate the DC value of an objective function. The imaginary part of the Gabor function used in (3) is expressed as

$$g_o^i = \exp \left\{ -\frac{\left[(x-t_x^i) \cos\theta^i - (y-t_y^i) \sin\theta^i \right]^2}{2(\sigma_x^i)^2} - \frac{\left[(x-t_x^i) \sin\theta^i + (y-t_y^i) \cos\theta^i \right]^2}{2(\sigma_y^i)^2} \right\} \times \sin \left(2\pi\omega_x^i \left[(x-t_x^i) \cos\theta^i - (y-t_y^i) \sin\theta^i \right] \right) \quad (4)$$

where t_x^i, t_y^i are the translation parameters of the Gabor wavelet, and the rest parameters are the corresponding parameters of Gabor wavelets as defined in (1). The network input vector $[x \ y]$ is the position of a pixel in a studied image IM , and the output is the grey level of the corresponding pixel. Fig. 2 depicts the architecture for a Gabor wavelet network. In the network, there are five parameters for each Gabor wavelet, which should be determined by the network learning process, including the translation parameters, orientation, radial frequency bandwidth, centre frequency, and the corresponding weight. The objective function of the learning process is defined as

$$E = \min \left\| IM - \sum_i w_i g_i \right\|_2^2 \quad (5)$$

In fact, GWN is a combination of feed forward neural network (FFN), namely multi-layer perceptron (MLP) and the Gabor wavelet decomposition. Various experiments [14-17] show that GWN is an effective and task-specific feature extractor.

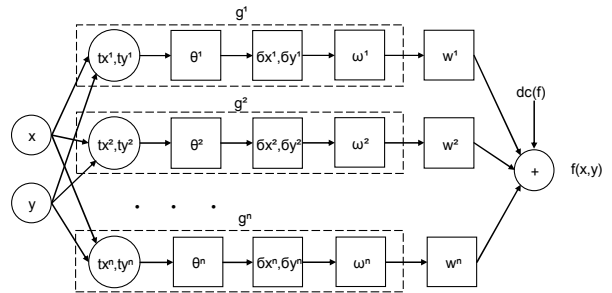

Fig. 2 The structure of a Gabor wavelet network.

IV. OPTIMAL GABOR FILTER DESIGN

This section proposes a GWN based method for designing optimal Gabor filters to segment fabric defects. Furthermore, a semi-supervised segmentation scheme is developed, which consists of two parts, including supervised training and unsupervised segmentation. The supervised part uses a non-defective fabric image as the template to train a GWN in order to determine the parameters of optimal Gabor filters, and by using the obtained optimal Gabor filters, the unsupervised

part carries out defect segmentation for fabric images with the same texture background as the template image, which are either defective or non-defective.

Fig. 3 displays an application of a GWN. Fig. 3(a) shows an image captured from twill weaving fabrics, which is used to train a GWN, and Fig. 3(b) is the corresponding reconstruction result by using the trained GWN. In Fig. 3(b), the basic texture information of the fabric image, including yarn direction and width, is entirely acquired by the GWN. Fig. 3(c) shows the difference between the original image and the reconstruction result. The energy in this difference image is so low that there is no obvious difference that can be noticed. However, the textile image is reconstructed with more than one hundred imaginary Gabor wavelets. In fact, only one imaginary Gabor filter is enough to obtain the basic yarn information. Fig. 4 shows such an example, in which Fig. 4(b) is the image reconstruction result by the GWN with only one imaginary Gabor wavelet in the hidden layer. It is seen that such a GWN can also capture some local texture information in the template fabric image, including the yarn orientation and the yarn width.

Although it is unrealistic to obtain an exhaustive training set containing all possible fabric flaws, a non-defective template image is always available. This is the underlying idea of the proposed segmentation scheme. The GWN with one imaginary Gabor wavelet is trained by using a non-defective textile image. After training, the parameters of the imaginary Gabor wavelet have a direct relation with the yarn information in the trained template image, from which an optimal filter can be constructed for detecting fabric defects in the same type of textile fabrics. The following equations show how to construct an optimal imaginary Gabor wavelet filter from the transfer function of a trained GWN.

$$\begin{cases} \sigma_x = \sigma_x^{GWN} \\ \sigma_y = \sigma_x^{GWN} \\ \theta = \theta^{GWN} + \frac{\pi}{2} \\ \omega_x = \omega_x^{GWN} \end{cases} \quad (6)$$

In (6), $\{\sigma_x, \sigma_y, \theta, \omega_x\}$ denote the parameters of the optimal filter and $\{\sigma_x^{GWN}, \sigma_y^{GWN}, \theta^{GWN}, \omega_x^{GWN}\}$ are the parameters of the imaginary Gabor wavelet in a GWN optimized with a template image. σ_x^{GWN} and ω_x^{GWN} contain the width information of the yarn in the template, which can be used directly by the optimal filter. Since σ_y is the thickness of the filter, it can be set a value equal to σ_x . As known, defect detection is a process in which the background area is attenuated and the defect area is accentuated. The orientation of an optimal filter is set to different values for different types of fabrics. This paper only considers detecting those defects that are found on the most commonly used fabrics, including plain, twill and denim fabrics. In the actual textile industry, most fabric defects appear in some specific orientations, either in the direction of

motion (i.e. warp direction) or perpendicular to it (i.e. weft direction) [18] because of the nature of the weaving process. Therefore, in order to maximize the elimination for texture backgrounds, for the fabrics without the obvious yarn information like plain fabrics, the orientation of the optimal filter is set to $\pi/4$, whereas for the rest of the textile images captured from twill and denim fabrics, the orientation of the optimal filter can be set perpendicular to the yarn orientation obtained by the GWN.

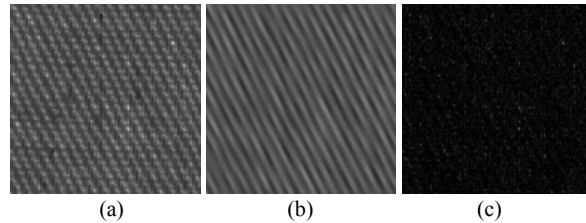

Fig. 3 A textile image (a), its reconstruction result with GWN (b), and the difference between the original image and reconstruction image (c).

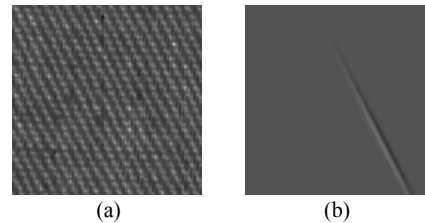

Fig. 4 A textile image (a) and its reconstruction result with only one imagery Gabor wavelet (b).

Fig. 5 shows an example of convoluting a fabric sample image with the 7×7 filter mask created by an optimal imaginary Gabor wavelet constructed in the method described above. By using the optimal filter obtained, most of the texture background can be effectively eliminated and at the same time the defective pixels are left. Indeed, the contrast between the background and the defect area is increased. This is exactly what a good defect detection scheme requires.

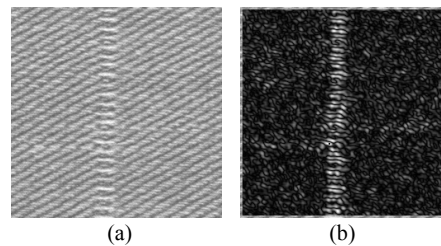

Fig. 5 A sample textile image with a defect (a) and the convoluting result with the optimal imaginary Gabor wavelet filter (b)

Based on such an optimal Gabor filter, a defect detection scheme is proposed in Fig. 6. In the figure, it can be found that

after a textile image is filtered by using an optimal Gabor filter (Odd_GW), the produced result will be smoothed by using a Gaussian filtering mask to reduce noise in the output image.

In the proposed detection scheme, a Gaussian low pass filter is used as the smoothing filter to reduce speckle-like noise [19] in the resulting output image of the designed filter, which is governed by

$$\text{gauss}(x, y) = \frac{1}{\sqrt{2\pi}\sigma} \exp\left(-\frac{x^2 + y^2}{2\sigma^2}\right). \quad (7)$$

According to the research results by Jain and Furrokhnia [20], it is the most appropriate to choose $\sigma = 1/(2\sqrt{2}f_0)$, where f_0 is the central frequency. In the case of this study, f_0 depends on the width of one yarn, i.e., the number of pixels occupied by one yarn in an image. Therefore, f_0 can be set equal to ω_x^{GWN} . Considering both the computational effort involved and the filtering quality, in the proposed detection scheme, the sizes of the masks created from the Gaussian smoothing filter and the optimal imaginary Gabor filter are both set to 7×7 .

In Fig. 6, the thresholding limits can be determined by filtering a defect-free template image with an optimal Gabor filter and a smoothing filter to obtain a new image **B**. The thresholding limits can be obtained from this image **B** as follows:

$$\begin{cases} \lambda_{\max} = \max_{x,y \in W} |\mathbf{B}(x, y)| \\ \lambda_{\min} = \min_{x,y \in W} |\mathbf{B}(x, y)| \end{cases}, \quad (8)$$

where W is a sub-window centered at the image **B**. The size of this window should be chosen to avoid the edge distortion part in the image. Thus, the thresholding values, λ_{\max} and λ_{\min} , are the maximum and minimum values of grey levels respectively. This process is carried out as a part of calibration at the beginning of inspection. The binarization process can be conducted by expressed in the following equation

$$\mathbf{D}(x, y) = \begin{cases} 1, & \mathbf{B}(x, y) > \lambda_{\max} \text{ or } \mathbf{B}(x, y) < \lambda_{\min} \\ 0, & \lambda_{\min} \leq \mathbf{B}(x, y) \leq \lambda_{\max} \end{cases}. \quad (9)$$

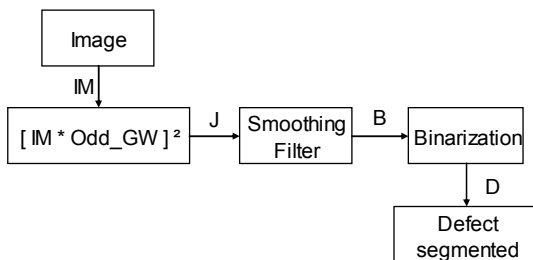

Fig. 6 Block diagram of the defect detection scheme based on the optimal imaginary Gabor wavelet filter

V. EXPERIMENTS AND RESULTS

The performance of the proposed defect segmentation scheme is evaluated by a test database consisting of 78 fabric images with 256×256 pixels (8 bit grey level range). In the database, 39 images are defect-free, and the rest contains different types

of fabric defects. Thirty two defects which commonly appear in the textile industry are tested. The types of fabrics included in the database are mainly plain, twill, denim weaving fabrics. The performance for the scheme is determined by visually assessing the binary output images. True detection (TD) is recorded when the white zone overlaps the defective area in a defective image and at the same time there is no other white areas appearing in the non-defective region or when no any white zone appears after detection for a non-defective image. False alarm (FA) is recorded when for a defective image the defective zone is overlapped and white areas also appear significantly distant from the defective area or when for a non-defective image white areas appear in the final binary result. Overall detection (OD) is the sum of TD and FA. Misdetection (MD) means that for a defective image the defective area is entirely lost. A Pentium III-450 MHz PC with 512M RAM is used to run the developed defect detection software.

Table I summarizes the test results and Fig. 7 shows some of the corresponding detection results. After fabric images are filtered by optimal Gabor filters and the Gaussian smoothing filter, the results should be binarized, and the final detection results are presented in Fig. 7(c),(g),(j),(m),(p),(s),(v),(y). It is found that the proposed scheme can successfully segment the defects with different shapes, different positions and different texture backgrounds.

The test fabric defects include both structural defects and tonal defects. The structural defect alters the textural property in an image, without which a good quality surface can be achieved, such as Fig. 7(h), (k) and (n), and the tonal defect changes the tonal property rather than the structural property, such as Fig. 7(a) and (q). Most of the defects in the test examples are local defects, which are observed as sudden changes in the structural or tonal properties of the image intensities.

Fig. 7(h) and (k) show fabric images with small defects which are visible only with difficulty. Those defects are successfully segmented with the scheme as shown in Fig. 7(j) and (m). Fig. 7(n) displays such an example in which the defect only changes the spatial arrangement of neighboring pixels and not mean gray level. The change is also enhanced by the scheme, and finally the defect is segmented as shown in Fig. 7(p).

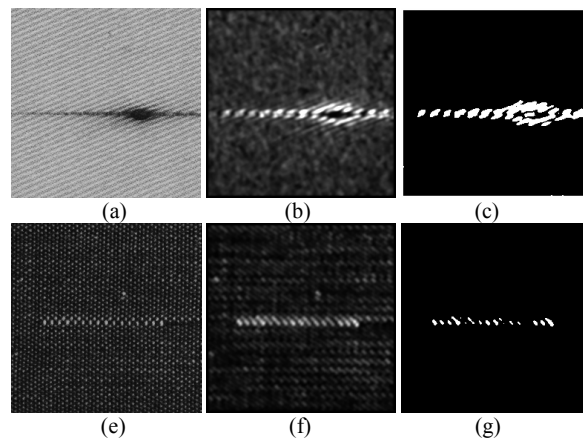

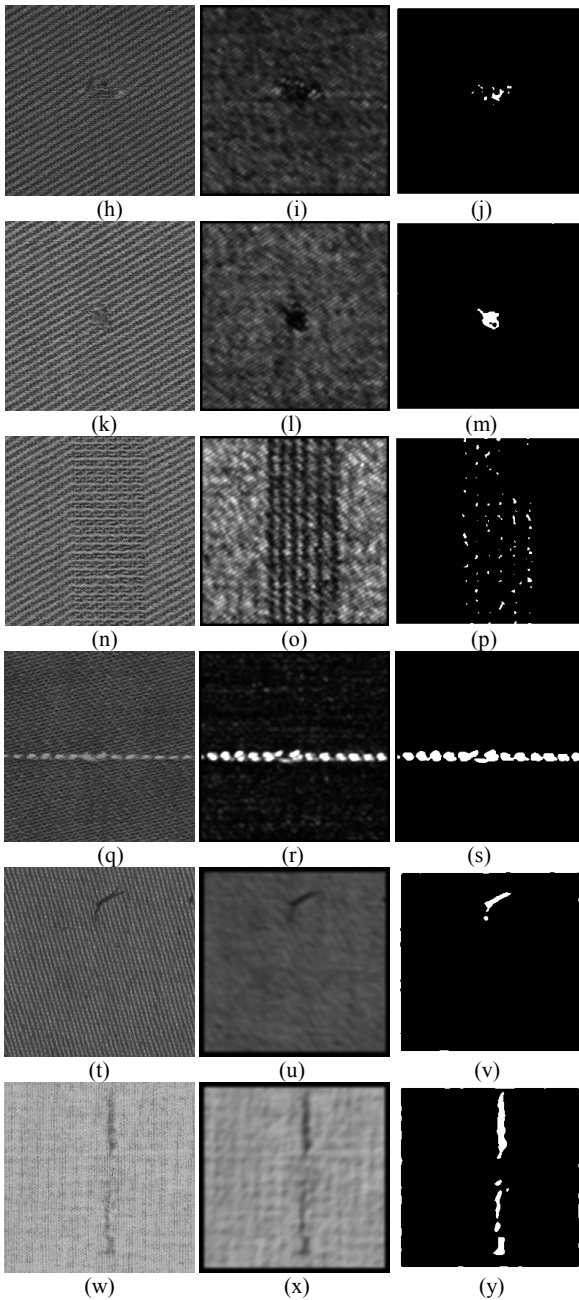

Fig. 7 Fabric samples with soiled end, warp float, burl, knot, harness breakdown, foreign fiber, big knot and gout in (a), (e), (h), (k), (n), (q), (t) and (w) respectively; corresponding local energy estimates with optimal imaginary Gabor filters in (b), (f), (i), (l), (o), (r), (u) and (x); the final defect segmentation results with the scheme of fig. 6 in (c), (g), (j), (m), (p), (s), (v) and (y)

When a piece of textile fabric gets off the production line, the locations and sizes of fabric defects vary randomly and dynamically. Therefore, the supervised algorithm only with respect to some particular defects sometimes does not work very well in the real application. In this sense the unsupervised detection algorithms should be preferred. However, the design

of an unsupervised algorithm is rather complicated and the algorithm usually needs a set of filters. The obvious disadvantage of using a set of filters is the huge amount of computations. Therefore, the optimal Gabor filters based on semi-supervised detection is a good choice, which can be designed to detect a class of textile fabrics. The design of an optimal filter needs to determine the values of four parameters $\{\sigma_x, \sigma_y, \omega_x, \theta\}$, which have a direct relation with the optimization output of a GWN. It is shown that the parameters are optimal and specific to a particular texture background. Based on this underlying idea, the detection scheme for textile fabrics is proposed, which performs satisfactorily in most of the test examples.

TABLE I
PERFORMANCE OF THE PROPOSED SCHEME

| The proposed scheme | Performance (Hit ratio) |
|------------------------|-------------------------|
| Overall Detection (OD) | 77 (98.7%) |
| Mis-detection (MD) | 1 (1.28%) |
| False Alarm (FA) | 6 (7.69%) |

A. Real Time Test

In order to evaluate the proposed detection scheme in real time, a prototyped detection system has been developed in our laboratory. The architecture of the defect detection system proposed is schematically described in Fig. 8. The system consists of a fabric conveying module, a lighting module, an image acquisition module, a supporting frame and a detection algorithm. Sari-Sarraf and Goddard [18] indicated that the following problems had to be considered when designing such an inspection system: (1) the vibration caused; (2) the irregular motion of the fabric; and (3) the system cost. All these points have been considered in developing the proposed inspection system.

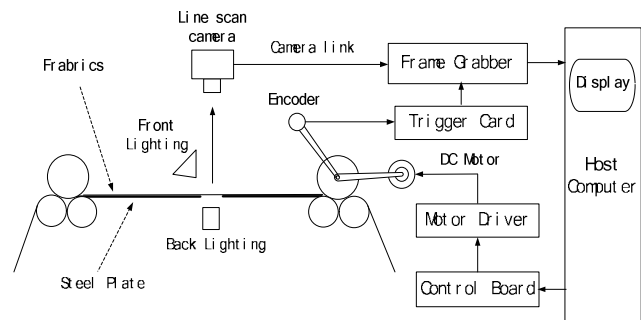

Fig. 8 Architecture of the vision inspection system

The image acquisition module mainly consists of a line scan camera with the model of L103k-2k made by Basler (Germany) and a frame grabber with the model of Matrox Odyssey XCL made by Matrox (US), and a camera link connects these two components. Thus, an image can be captured by the frame grabber interfaced to the camera by the camera link. Although in some detection applications area scan cameras can be used instead, compared to an area scan camera, a line scan camera

has several advantages, such as a fast image acquisition speed, low signal noise and high resolution. In addition, a disc encoder is installed to ensure the synchronization of the camera with the fabric transportation velocity. The exposure time of the camera is fixed regardless of the motion speed of the fabric as long as it is less than the period of the TTL line trigger signal. A Matrox Oasis chip is integrated in the frame grabber, which can speed up the data processing. The resolution of pick direction is set by the optics of the camera which can be adjusted by changing the distance between the camera and the fabric, and the resolution of the warp direction is set by the size of the roller and the resolution of the encoder which can be partially modified by a file called digitizer configuration file (DCF) in the host computer.

The performance of the proposed detection scheme is evaluated online by using the developed prototype detection system. The system is adjusted to capture a frame with the size of pixels in 8-bit grey level, and the image resolution is about 7.8 pixels per mm in both of the directions. The fabric conveying speed is about 20 meters per minute. Since comparing to plain weaving fabrics twill weaving fabric is with a more complicated pattern and the sizes of some defects are only about one yarn width, it is much more difficult to be detected. In the on-line test, a long piece of twill weaving fabric is used as the detection objective, and 276 frames of images are captured and analyzed, in which 17 images contains different defects, including oil spot, burl, knot with halos, and the rest are defect-free. Because it is very difficult to obtain a long piece of fabric with a variety of fabric defects, most of the defects in this test are deliberately made by hands. In this test of the proposed detection scheme, 2 fabric images are misdetected (MD), and an 8.0% false alarm rate is achieved. It can be noticed that the achieved good detection results show the robustness of the proposed detection scheme.

VI. CONCLUSION

In this paper, a semi-supervised defect detection scheme for textile fabrics has been proposed, which is constructed based on optimal Gabor filters. Gabor wavelet network with only one wavelet in the hidden layer is utilized as the major technique to obtain the basic texture features of the studied textile images, and the obtained features serve as the priori knowledge to design those optimal Gabor filters.

The performance of the scheme has been extensively evaluated by using an offline test database, which consists of a variety of fabric defects differing in defect type, size and shape, texture background, and image resolution. The test results obtained have shown that the scheme is simple, effective and robust. In addition, the proposed detection scheme is also evaluated by using a developed prototyped detection system. The obtained good detection results confirm the efficiency and robustness of the detection scheme.

REFERENCES

[1] K. Srinivasan, P. H. Dastoor, P. Radhakrishnaiah, and S. Jayaraman,

- “FDAS: A knowledge-based framework for analysis of defects in woven textile structures”, *J. Textile Inst.*, pt. 1, vol. 83, no. 3, pp. 431-448, 1992.
- [2] H. Sari-Sarraf and J. S. Goddard, “Vision systems for on-loom fabric inspection”, *IEEE Trans. Ind. Appl.*, vol. 35, pp. 1252-1259, Nov-Dec, 1999.
- [3] J. Wang, R.A. Campbell, and R.J. Harwood, “Automated inspection of carpets”, in *Proc. SPIE*, vol. 2345, 1995, pp. 180-191.
- [4] J. Escofet, R. Navarro, M. S. Millan, and J. Pladellereans, “Detection of local defects in textiles webs using Gabor filters”, *Opt. Eng.*, vol. 37, pp. 2297-2307, Aug. 1998.
- [5] A. Kumar and G. Pang, “Fabric defect segmentation using multichannel blob defectors”, *Opt. Eng.*, vol. 39, no.12, pp. 3176-3190, 2000.
- [6] A. Kumar and G.K.H. Pang, “Defect detection in textured materials using Gabor filters”, *IEEE Trans. Ind. Appl.*, vol. 38, no.2, pp. 425-440, 2002.
- [7] A. Bodnarova, M. Bennamoun and S. Latham, “Optimal Gabor filters for textile flaw detection”, *Pattern Recognition*, vol. 35, pp. 2973-2991, 2002.
- [8] P. Vautrot, N. Bonnet and M. Herbin, “Comparative study of different spatial/spatial-frequency methods (Gabor filters, wavelets, wavelets packets) for texture segmentation/classification”, in *Proceedings of the 1996 IEEE Inter. Conf. Image Processing, ICIP'96*, vol. 3, 1996, pp. 145-148.
- [9] A. Teuner, O. Pichler and B.J. Hosticka, “Unsupervised texture segmentation of images using tuned matched Gabor filters”, *IEEE Trans. Image Processing*, vol. 4, no. 6, pp. 863-870, 1995.
- [10] D. Casasent and J.S. Smokelin, “Neural net design of macro Gabor wavelet filters for distortion-invariant object detection in clutter”, *Opt. Eng.*, vol. 33, no. 7, pp. 2264-2271, 1994.
- [11] R. Mehrotra, K.R. Namuduri, and N. Ranganathan, “Gabor Filter-Based Edge Detection”, *Pattern Recognition*, vol. 25, no. 12, pp. 1479-1494, 1992.
- [12] Qinghua Zhang and Albert Benveniste, “Wavelet networks”, *IEEE transactions on Neural Networks*, vol. 3, no. 6, pp. 889-898, November 1992.
- [13] V. Krueger and G. Sommer, “Gabor wavelet networks for object representation”, *DAGM Symposium*, Germany, September 2000, pp. 13-15.
- [14] Volker Kruger and Gerald Sommer, “Gabor wavelet networks for efficient head pose estimation”, *Image and vision computing*, vol. 20, pp. 665-672, 2002.
- [15] V. Krueger, “Gabor wavelet networks for object representation”, Ph.D thesis, Christian Albrechts University, Germany, 2001.
- [16] Rogerio S. Feris and Roberto M. Cesar Junior, “Tracking facial features using Gabor wavelet networks”, *Computer graphics and image proceeding, proceedings XII Brazilian Symposium on*, 2000, pp. 22-27.
- [17] K. L. Mak and P. Peng, “Defect Detection in Textile Fabrics Using Gabor Wavelet Networks”, *18th International Conference on Computer Applications in Industry and Engineering*, Hawaii, USA, November 9-11, 2005, pp. 226-231.
- [18] H. Sari-Sarraf, J.S. Goddard, “Vision systems for on-loom fabric inspection”, *IEEE Trans. Ind. Appl.*, vol. 35, pp. 1252-1259, 1999.
- [19] A.K. Jain and K. Karu, “Learning texture discrimination masks”, *IEEE Trans. Pattern Anal. Mach. Intell.*, vol. 18, pp. 195-205, 1996.
- [20] A.K. Jain and F. Furrokhnia, “Unsupervised texture segmentation using Gabor filters”, *Pattern Recognition*, vol. 23, pp. 1167-1186, 1991.