

PSS and SVC Controller Design by Chaos and PSO Algorithms to Enhancing the Power System Stability

Saeed jalilzadeh, Mohammad Reza Safari Tirtashi, Mohsen Sadeghi

Abstract—this paper focuses on designing of PSS and SVC controller based on chaos and PSO algorithms to improve the stability of power system. Single machine infinite bus (SMIB) system with SVC located at the terminal of generator has been considered to evaluate the proposed controllers where both SVC and PSS have the same controller. The coefficients of PSS and SVC controller have been optimized by chaos and PSO algorithms. Finally the system with proposed controllers has been simulated for the special disturbance in input power of generator, and then the dynamic responses of generator have been presented. The simulation results showed that the system composed with recommended controller has outstanding operation in fast damping of oscillations of power system.

Keywords—PSS,CHAOS,PSO,Stability

I. INTRODUCTION

POWER systems experience low frequency oscillations (in the range of 0.1 Hz to 2.5Hz) during and after a large or small disturbance has happened to a system, especially for middle to heavy loading conditions [1]. These oscillations may sustain and grow to cause system separation if no adequate damping is available [2]. Power System Stabilizers (PSSs) are the most cost effective devices used to damp low frequency oscillations. For many years, Conventional PSS (CPSSs) have been widely used in the industry because of their simplicity [3]. To improve the performance of CPSSs, numerous techniques have been proposed for their design, such as using intelligent optimization methods (simulated annealing, genetic algorithm, tabu search) [4], fuzzy, neural networks and many other nonlinear control techniques. During some operating conditions, PSS may not produce adequate damping, and other effective alternatives are needed in addition to PSS. Recent development of power electronics introduces the use of Flexible AC Transmission Systems (FACTS) controllers in power systems [5]. FACTS utilize high power semiconductor devices to control the reactive power flow and thus the active power flow of the transmission system so that the ac power can be transmitted through a long distance efficiently [6]. The conception of FACTS as a total network control philosophy was first introduced by N.G. Hingorani [7] from the Electric Power Research Institute (EPRI) in the USA in 1988, although the power electronic controlled devices had been used in the transmission network for many years before that. The FACTS devices may be connected so as to provide either series compensation or shunt compensation depending upon their compensating strategies. [8].

Nowadays, Static Var Compensator (SVC) is one of the key elements in the power system that provides the opportunity to improve power quality and reliability due to its fast response. SVC has the functional capability to handle dynamic conditions, such as transient stability and power oscillation damping in addition to providing voltage regulation [6]. Due to the characteristics of power transmission systems, the FACTS Compensator control algorithm must be designed resorting to control methods capable to deal with system nonlinearities and unknown disturbances [9]. In this paper the PSS and SVC have the same controller, that their coefficients have been optimized by chaos and PSO algorithms. Then the system with proposed controller has been simulated for the special disturbance and the dynamic response of generator has been represented.

II. MODEL OF PROPOSED SYSTEM

A synchronous machine with an IEEE type-ST1 excitation System connected to an infinite bus through a transmission Line has been selected to demonstrate the derivation of simplified linear models of power system for dynamic stability analysis [10]. Fig. 1 shows the model consists of a generator supplying bulk power to an infinite bus through a transmission line, with an SVC located at its terminal. The equations that describe the generator and excitation system have been represented in following equations:

$$\dot{\delta} = \omega_0(\omega - 1) \quad (1)$$

$$\dot{\omega} = (P_m - P_e - D(\omega - 1))/M \quad (2)$$

$$\dot{E}_q' = (E_{fd} - (X_d - X_d')id - E_q')/\tau'do \quad (3)$$

$$\dot{E}_{fd} = (K_A(V_{ref} - V_t + U_{pss}) - E_{fd})/T_A \quad (4)$$

Where

$$P_e = V_{td} I_d + V_{tq} I_q \quad (5)$$

Authors are with Zanjan University, Iran. e-mail:safazliir@yahoo.com

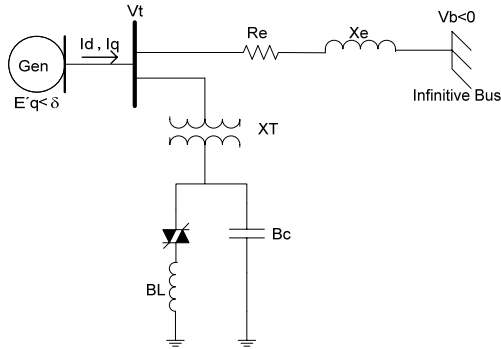

Fig. 1. Single machine-infinite bus system model with SVC.

$$V_t = V_{td} + jV_{tq} \quad (6)$$

$$V_{td} = X_q I_q \quad (7)$$

$$V_{tq} = E'_q - X'_d I_d \quad (8)$$

δ is the rotor angle, V_b the infinite bus voltage, ω the rotor speed, P_m the mechanical input power, P_e active power, E'_q the internal voltage, E_{fd} the excitation voltage, and V_{ref} is the reference voltage. The constant values of these equations have been represented in Table 1.

III. STATIC VAR COMPENSATOR

SVC is a currently widely used FACTS device in power systems. By adjusting the firing angle, it can provide smoothly and rapidly reactive power control and therefore, provide great control to the bus voltage. In addition, SVC can enhance the transient stability [11] and provide additional damping to power systems as well [12].

SVC is mainly operated at load side bus and used as replacement for existing voltage control devices [13]. A basic topology of SVC consists of a series capacitor bank C in parallel with a thyristor controlled reactor L, is shown in Fig. 2. The SVC can be seen as an adjustable susceptance which is a function of thyristors firing angle.

IV. POWER SYSTEM LINEARIZED MODEL

A linear dynamic model is obtained by linearizing the nonlinear model round an operating condition ($P_e=1$, $Q_e=0.59$). The linearized model of power system as shown in Fig. 1 is given as follows:

$$\dot{\Delta\delta} = \omega_o \Delta\omega \quad (9)$$

$$\dot{\Delta\omega} = \frac{\Delta P_m - \Delta P_e}{M} \quad (10)$$

$$\dot{\Delta E'_q} = \frac{\Delta E_{fd} - (X_d - X'_d)\Delta i_d - \Delta E'_q}{\tau'_{do}} \quad (11)$$

$$\dot{\Delta E_{fd}} = (K_A(\Delta V_{ref} - \Delta V_t + U_{pss}) - \Delta E_{fd})/T_A \quad (12)$$

$$\Delta P_e = K_1 \Delta\delta + K_2 \Delta E'_q + K_3 \Delta B_{svc} \quad (13)$$

$$\Delta V_t = K_4 \Delta\delta + K_5 \Delta E'_q + K_6 \Delta B_{svc} \quad (14)$$

K_1, K_2, \dots, K_6 are linearization constants.

TABLE I SYSTEM PARAMETERS

$X_d=1.7$	$X_q=1.64$
$X'_d=0.245$	
$D=0$	$H=2.37$
$X_T=0.08$	$\tau'_{do}=5.9$
$X_e=0.4$	$Re=0.02$

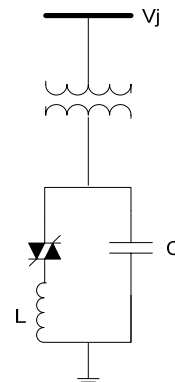

Fig. 2. Basic SVC topology

V. CHAOS OPTIMISATION ALGORITHM

Chaos is a general phenomenon in non-line system. It can get all the states in the search space by the rules of itself. Moreover, a tiny change of initial values can lead to a big change of the system. The chaos search can generate the neighbourhoods of near-optimal solutions to maintain solution diversity. It can prevent the search process from becoming premature. The chaos optimization method based on Chaos Search is proposed to avoid the local optimal [14]. Chaos variables are usually generated by the well known logistic map. The logistic map is a one-dimensional quadratic map defined by (15)

$$\gamma_i(k+1) = \beta\gamma_i(k)(1-\gamma_i(k)) \quad (15)$$

Where β is a control parameter and $0 \leq \gamma_i(0) \leq 1$. Despite the apparent simplicity of the equation, the solution exhibits a rich variety of behaviours. For $\beta = 4$ system (15) generates chaotic evolutions. Its output is like a stochastic output, no value of $\gamma_i(k)$ is repeated and the deterministic equation is sensitive to initial conditions. Those are the basic characteristics of chaos. Chaos variable $\gamma_i(0)$ is mapped into

the variance ranges of optimisation variables by the following equations [15]:

$$x_i(k) = x_i^* + \alpha_i(2\gamma_i(k) - 1) \quad (16)$$

$$\alpha_i = 0.01(b_i - a_i), x_i = [a_i, b_i] \quad (17)$$

Where χ is optimization variable, χ^* is the best experiment of variable, and α is the feasible region. Fig 3 shows the flowchart of chaos algorithm.

VI. PSO ALGORITHM

The particle swarm optimization (PSO) algorithm was first proposed by Kennedy and Eberhart [16] Where is a novel evolutionary algorithm paradigm which imitates the movement of birds flocking or fish schooling looking for food. Each particle has a position and a velocity, representing the solution to the optimization problem and the search direction in the search space The particle adjusts the velocity and position according to the best experiences which are called the pbest found by itself and gbest found by all its neighbors. In PSO algorithms each particle moves with an adaptable velocity within the regions of decision space and retains a memory of the best position it ever encountered. The best position ever attained by each particle of the swarm is communicated to all other particles. The updating equations of the velocity and position are given as follows [17]:

$$v_i(k+1) = wv_i(k) + r_1c_1[p_i - x_i(k)] + r_2c_2[p_{gi} - x_i(k)] \quad (18)$$

$$x_i(k+1) = x_i(k) + v_i(k+1) \quad (19)$$

Where v is the velocity and x is the position of each particle. c_1 and c_2 are positive constants referred to as acceleration constants and must be $c_1+c_2 \leq 4$, usually $c_1=c_2=2$. r_1 and r_2 are random numbers between 0 and 1, w is the inertia weight, p refers to the best position found by the particle and p_g refers to the best position found by its neighbors. Fig 4 shows the flowchart of PSO algorithm.

VII. SIMULATION RESULTS

The deviation of speed that obtained from linearization has been selected for inputs of PSS and SVC controller which is shown in Fig. 5. As specified by Fig. 5 PSS and SVC have the same Lead-lag controller. The constant values of Fig. 5 have been represented in Table 2.

The fitness function used in this paper for chaos and PSO algorithms is represented in (20) that t_{sim} is the simulation time, dw is the deviation of speed and dv_t is the deviation of terminal voltage of generator.

$$fitness = \int_0^{t_{sim}} [10 * |dw| + |dvt|] dt \quad (20)$$

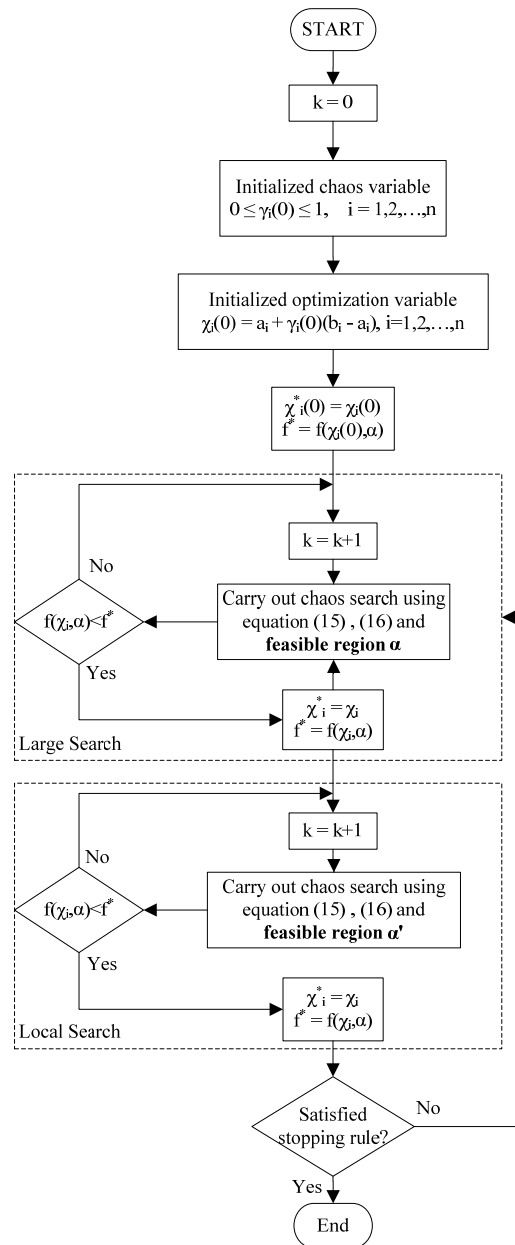

Fig. 3 Flowchart of the chaos algorithm

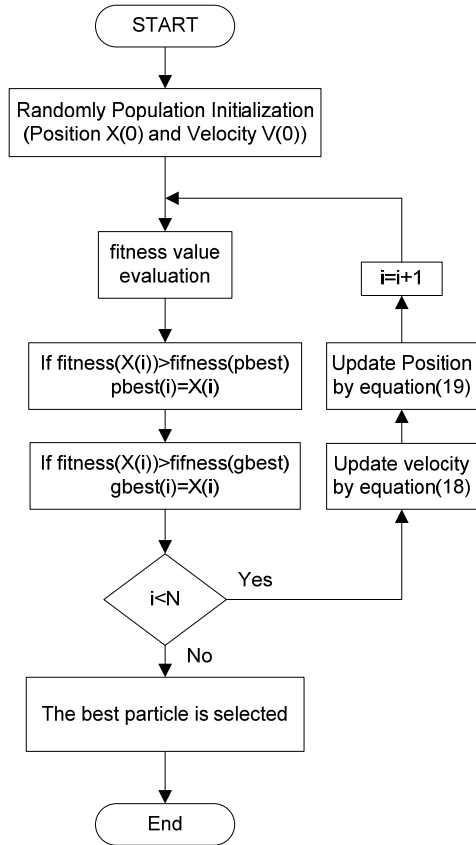

Fig. 4 Flowchart of the PSO algorithm

The deviation of speed (Δw) has been multiplied by 10 to both section of fitness have the same range. Control parameters and their boundaries are given below:

$$0 < K < 50 \quad (21)$$

$$0.01 < T_1 < 1 \quad (22)$$

$$0.01 < T_2 < 1 \quad (23)$$

The convergence of the PSO and chaos algorithms is represented in Fig. 6. As specified by Fig. 6 the PSO algorithm is faster than chaos algorithm to achieve the optimum coefficients. Table 3 shows the optimized parameters that found by PSO and chaos algorithms. Optimized parameters have been earned when the input power of generator has been changed 5% instantaneously and the operating condition was $P_e=1$ and $Q_e=0.59$. Fig. 7 shows the system dynamic response for a six cycle fault disturbance for rotor speed variation, rotor angle variation and terminal voltage variation for following three state,

- with PSO controller
- with chaos controller
- Non-controller

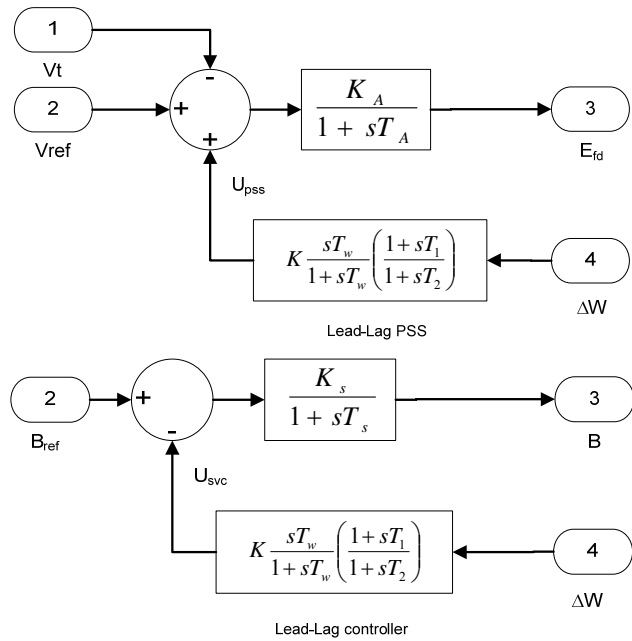

Fig. 5 PSS and SVC controller

TABLE II CONSTANT VALUES

K_A [P.U]	T_A [P.U]	T_w [P.U]	K_s [P.U]	T_s [P.U]
200	0.02	10	10	0.15

TABLE III OPTIMIZED VALUES

	PSO	chaos
K	3.84	3.63
T_1	0.18	0.19
T_2	0.01	0.01

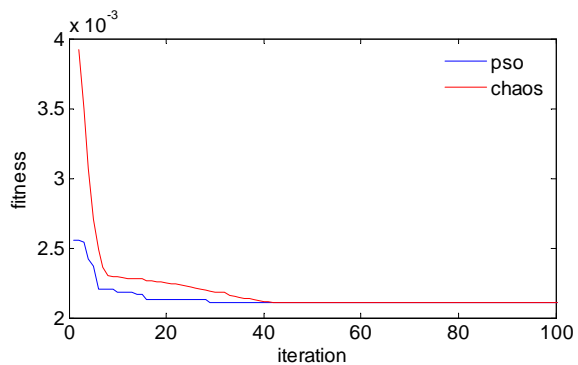

Fig. 6 Convergence of PSO and chaos algorithms

REFERENCES

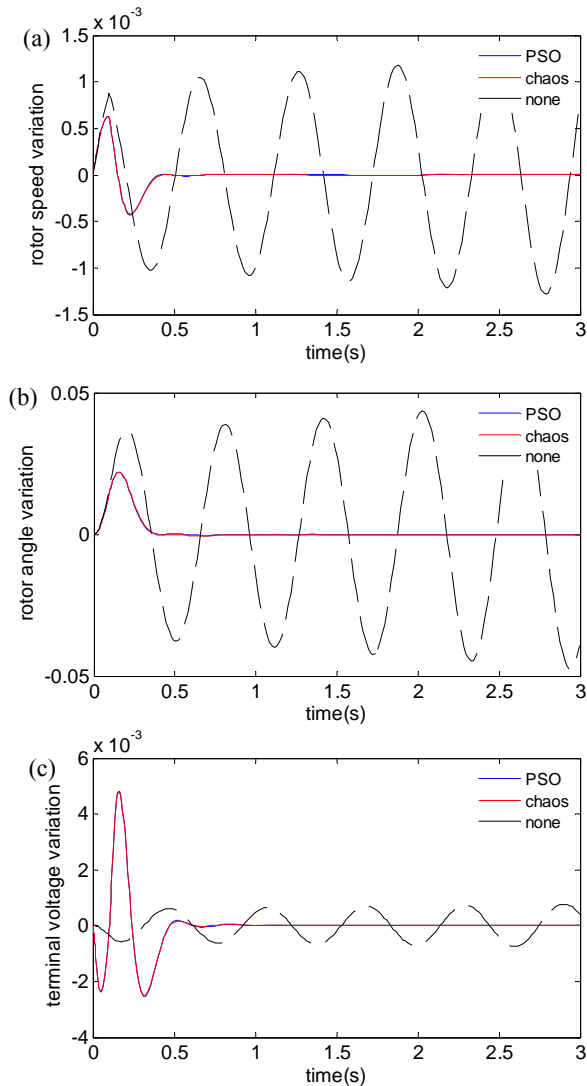

Fig. 7 system dynamic response for a six cycle fault disturbance. (a) rotor speed variation, (b) rotor angle variation, (c) terminal voltage variation

VIII. CONCLUSION

In this paper the SMIB system where SVC located at the terminal of generator has been considered. The SVC and PSS have the same controller where their optimized coefficients have been earned by chaos and PSO algorithms. In order to show the excellent operation of proposed controller, the input power of generator has been changed 5% instantaneously and the system with proposed controllers has been simulated, then the dynamic response of generator for rotor speed variation, rotor angle variation and terminal voltage variation have been represented. The simulation results showed that the system composed with proposed controller has superior operation in fast damping of oscillations of power system.

- [1] S. Sheetekela, K. Folly, and O. Malik, " Design and Implementation of Power System Stabilizers based on Evolutionary Algorithms," *IEEE conference* , pp. 1-6, 2009.
- [2] M.A. Abido, and Y.L. Abdel-Magid, " Coordinated design of a PSS and an SVC-based controller to enhance power system stability," *International journal of Electrical Power and Energy Systems*, pp. 695-704, 2003.
- [3] A. Phiri, and KA Folly, " Application of Breeder GA to Power System Controller Design," *IEEE conference* , pp. 1-5, 2008.
- [4] Wenxin Liu, Ganesh K, Venayagamoorthy, Donald C, and Wunsch II, " Adaptive Neural Network Based Power System Stabilizer Design," *IEEE conference* , pp. 2970-2975, 2003.
- [5] S. Panda, "Multi-objective non-dominated shorting genetic algorithm-II for excitation and TCSC-based controller design," *journal of Electrical Engineering*, vol. 60, NO. 2, pp. 86-93, 2009.
- [6] N. G. Hingoran and L. Gyugy, " Understanding FACTS, Concepts and Technology of Flexible AC Transmission System," New York: Inst. Elect. Electron. Eng., Inc., 2000.
- [7] N.G. Hingorani, "High power electronics and flexible AC transmission system," *IEEE Power Engineering review*, july 1988.
- [8] R. Jayabarathi, M .R Sindhu, N. Devarajan , and T. N. P. Nambiar, " Development of a Laboratory Model of Hybrid Static Var Compensator," *IEEE conference*, 2006.
- [9] P.F. Puleston *, S.A. Gonza'lez, and F. Valenciaga, " A STATCOM based variable structure control for power system oscillations damping," *International journal of Electrical Power and Energy Systems*, pp. 241-250, July 2006.
- [10] Y.P. Wang, D.R. Hur, H.H. Chung, N.R. Watson, J. Arrillaga, S.S. Matair, " A Genetic Algorithms Approach To Design Optimal PI Controller For Static Var Compensator," *IEEE conference* , pp. 1557-1562, 2000.
- [11] Tso SK, Liang J, Zeng QY, Lo KL, Zhou XX, " Coordination of TCSC and SVC for stability improvement of power systems," *Proceedings of the fourth international conference on advances in power system control, operation and mangement*, pp. 371-376, November 1997.
- [12] Padiyar KR, Varma RK, " Damping torque analysis of static var system controllers," *IEEE Trans Power Syst* .pp. 458-465, 1991.
- [13] Y.P. Wang, D.R. Hur, H.H. Chung, N.R. Watson, J. Arrillaga, S.S. Matair, " A Genetic Algorithms Approach To Design Optimal PI Controller For Static Var Compensator," *IEEE conference* , pp. 1557-1562, 2000.
- [14] Su Wang, and Bo Meng, " Chaos Particle Swarm Optimization for Resource Allocation Problem," *IEEE conference* , pp. 464-467, 2007.
- [15] L. Shengsong, W. Min and H. Zhijian, " Hybrid algorithm of chaos optimisation and SLP for optimal power flow problems with multimodal characteristic," *IEE Proc.-Geneationr. Transmisoin. Distribution.*, Vol. 150, No. 5, September 2003.
- [16] Shan Miyuan, Wu Juan, and Peng Danni, " Particle Swarm and Ant Colony Algorithms Hybridized for Multi-mode Resource-constrained Project Scheduling Problem with Minimum Time Lag," *IEEE conference* , pp.5898-5902, 2007.
- [17] L. Zhao, and Y. Yang, " PSO-based single multiplicative neuron model for time series prediction," *International journal of Expert Systems with Applications*, pp. 2805-2812, 2009.