

Acoustic and Flow Field Analysis of a Perforated Muffler Design

Zeynep Parlar, Şengül Ari, Rıfat Yılmaz, Erdem Özdemir, and Arda Kahraman

Abstract—New regulations and standards for noise emission increasingly compel the automotive firms to make some improvements about decreasing the engine noise. Nowadays, the perforated reactive mufflers which have an effective damping capability are specifically used for this purpose. New designs should be analyzed with respect to both acoustics and back pressure. In this study, a reactive perforated muffler is investigated numerically and experimentally. For an acoustical analysis, the transmission loss which is independent of sound source of the present cross flow, the perforated muffler was analyzed by COMSOL. To be able to validate the numerical results, transmission loss was measured experimentally. Back pressure was obtained based on the flow field analysis and was also compared with experimental results. Numerical results have an approximate error of 20% compared to experimental results.

Keywords—Back Pressure, Perforated Muffler, Transmission Loss.

I. INTRODUCTION

MUFFLER design is an important research area for automotive companies because of new regulations and standards for noise emission. To examine the performance of any muffler, certain parameters are used. These parameters are transmission loss and back pressure. The transmission loss gives a value in decibel (dB) that corresponds to the ability of the muffler to dampen the noise. Transmission loss is independent from the noise source, thus this property of muffler does not vary with respect to noise source. New designs to improve the acoustical properties of a muffler cause a resistance against the flow of exhaust gases and this resistance stems the flow. This is called back pressure and it causes an extra pressure inside the engine. Because of the back pressure, volumetric efficiency decreases and specific fuel consumption increases. Therefore, there must be specific limitations for the back pressure [1].

Numerical analysis programs make the acoustic investigation of the muffler easier. In 2005, Daniel explained the general design principles of a muffler and advantages of different types of mufflers [2]. Mo and Huh calculated the acoustic transmission loss of muffler with basic and complex geometry using NASTRAN and the analytical results were

compared with the experimental results [3]. Munjal calculated the back pressure of a perforated, cross-flow and reactive muffler with CFD method and examined the effects of different parameters such as diameter and, area expansion ratio [4]. In a study published in 2007, Fairbrother and Varhos investigated the transmission loss and back pressure of a muffler with perforated pipe and baffle numerically [5]. Jiet et al. analyzed and compared acoustic results of a perforated, three pass muffler in 1D and 3D with or without an outlet resonator [6]. Fang et al. carried out research on pressure loss of a muffler using CFD method. Through using CFD technique, at a certain engine velocity, the flow field of a muffler was simulated and the total pressure distribution inside the muffler was analyzed [7]. In 2009, transmission loss of a three pass muffler was calculated analytically and compared with 3D analysis method [8].

In 2010, an exhaust system which is composed of a front and back muffler was examined to obtain flow field characteristic [9]. The flow inside the muffler was modeled with Fluent and the influences of the internal flow on the performance of the muffler were studied [10]. Kore et al. simulated a reactive muffler in Fluent. Not only the flow field but also the transmission loss was analyzed [11]. Vasileve Gillich calculated the transmission loss and propagation of harmonic pressure waves of a muffler of an internal combustion engine with COMSOL [12].

In this study, acoustic and flow characteristic of a perforated, cross-flow, three pass muffler were analyzed. First of all, for acoustical analysis, present muffler was simulated in COMSOL and sound pressure contours were obtained. Besides, transmission loss data were calculated numerically. For flow analysis of the present muffler, 3D model of the muffler was created with a CAD program and this model was meshed with ANSYS. Back pressure of the present muffler was obtained using CFD analysis.

II. MODEL BUILDING

CAD model of the present muffler which will be examined in this paper is shown in Fig. 1. As shown in Fig. 1, the muffler consists of perforated inlet and outlet pipes and two perforated baffles. The perforate rates of inlet and outlet pipes are approximately 30% and 12%, respectively. Furthermore, the muffler has three expansion chambers. Perforated parts of inlet and outlet pipes create a cross flow inside the muffler.

Zeynep Parlar is with Istanbul Technical University, Istanbul, Turkey (e-mail:parlarze@itu.edu.tr).

Şengül Ari is with Istanbul Technical University, Istanbul, Turkey (e-mail:aris@itu.edu.tr).

Rıfat Yılmaz is with Istanbul Technical University, Istanbul, Turkey (e-mail:yilmazri@itu.edu.tr).

Erdem Özdemir is with Istanbul Technical University, Istanbul, Turkey (e-mail:ozdemirerd@itu.edu.tr).

Arda Kahraman is with Renault Automotive Factory, Bursa, Turkey (e-mail:arda.kahraman@renault.com).

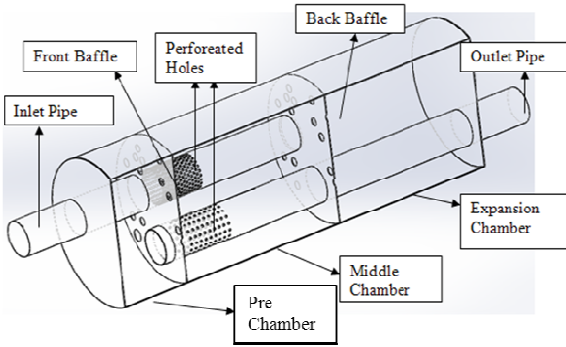

Fig. 1 CAD model of the present muffler

III. NUMERICAL CALCULATION

In this study, acoustic and flow characteristic of the present muffler were analyzed and the simulation results were compared with experimental results.

A. Acoustic Analysis Acoustic Measurements

As mentioned earlier, acoustic characteristics of a muffler can be determined with transmission loss. For this purpose, numerical simulations of the transmission loss of the present muffler were performed with COMSOL. In this calculation, the mean flow of the muffler was ignored. The geometry of the muffler was drawn with the same program. The straight and perforated parts of the pipes were drawn separately and perforate rates were entered into the program. For perforated baffle, holes were not drawn separately, instead, only four holes were drawn as they will have approximately the same center of gravity. Inlet and outlet parts of the muffler were chosen on the program. The muffler was meshed automatically with tetrahedral elements.

Minimum wavelength of a muffler is 0.327 m and in an acoustic examination, mesh size must be smaller than 1/6 of the wavelength. Thus, a mesh size of 0.019 m used in the modeled muffler.

In this program, sound pressure, p , was calculated with Helmholtz equation in (1).

$$\nabla \cdot \left(\frac{1}{\rho_0} \nabla p - q \right) + \frac{k^2 p}{\rho_0} = 0 \quad (1)$$

where, $k=2\pi f/c_0$ is the wavelength, ρ_0 is the density of the fluid and c_0 is the sound speed. q is two pole source term which means acceleration per unit volume and equals to 0 in this study. With this expression, a solution on frequency domain can be found using a parametric solver.

Transmission loss expression of the muffler was calculated with (2) as below:

$$TL = 10 \log \left(\frac{P_{in}}{P_{out}} \right) \quad (2)$$

where, P_{in} and P_{out} denote acoustic effects on inlet and outlet of the muffler, respectively. These acoustic effects are calculated with (3) and (4) as below:

$$P_{in} = \int_{\Omega} \frac{p_0^2}{2\rho c_0} dA \quad (3)$$

$$P_{out} = \int_{\Omega} \frac{|p_{cl}|^2}{2\rho c_0} dA \quad (4)$$

(2), (3) and (4) were given to the program as variable and inlet pressure value, p_0 , was set to 1 bar.

The model uses sound hard (wall) boundary conditions at the solid boundaries as shown in (5):

$$\left(-\frac{\nabla p}{\rho} \right) \cdot \mathbf{n} = 0 \quad (5)$$

3-D drawing of the geometry and the meshed geometry are shown in Fig. 2 and Fig. 3 respectively.

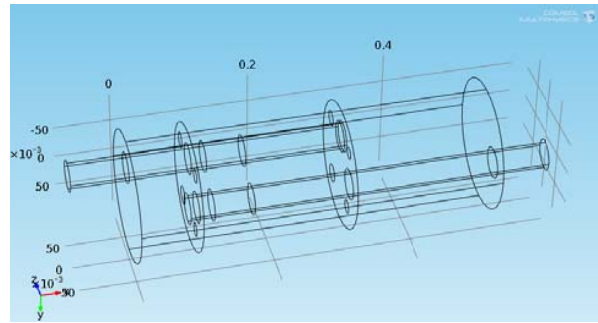

Fig. 2 3-D drawing of the geometry

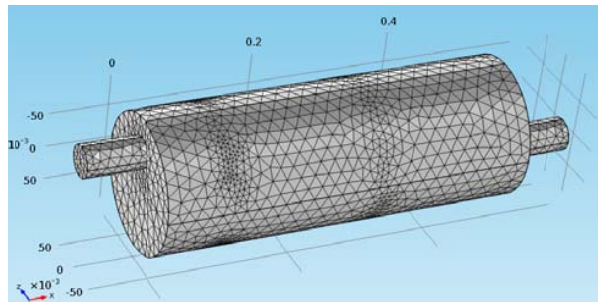

Fig. 3 Meshed geometry

B. Flow Field Analysis

For flow analysis of the muffler, present muffler was drawn via a 3D CAD program. This 3D muffler model was meshed using Ansys Workbench with tetrahedral elements. Since the muffler has a small wall thickness and small dimensions and especially the part of perforated holes causes problems during mesh generation, thus, hexagonal mesh was not used. In addition to this, boundary layers were generated for the outside liner of the muffler [13].

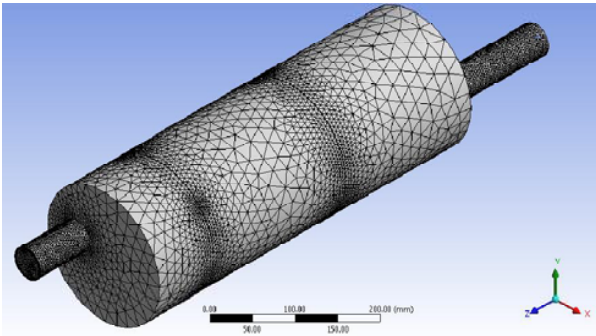

Fig. 4 3D mesh of the muffler geometry

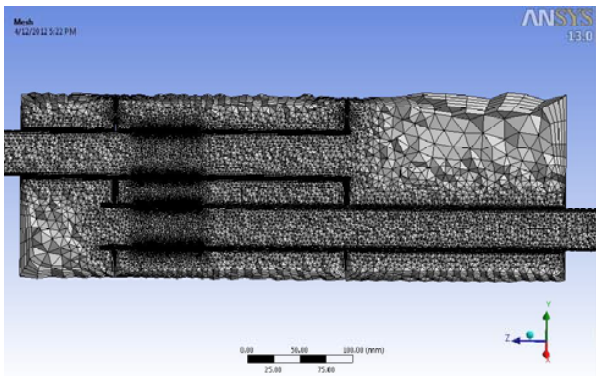

Fig. 5 3D tetrahedral mesh of the muffler (sectional view)

TABLE I
MESH STATISTICS

Element number	5498964
Node number	1510889
Maximum skewness	0.88

After the muffler was meshed, flow field analysis was performed with Fluent. The flow inside the muffler is assumed to be turbulence, so $k-\epsilon$ turbulence model was used in this study. Since the density is expected to change with temperature, energy equation was also solved in the program. Velocity and temperature were defined as inlet boundary conditions. Pressure and temperature were defined as outlet boundary conditions; the physical properties of air were defined for flow analysis. Boundary conditions are given in Table II. The simulations were performed for five different inlet velocities, namely, 23, 46, 70, 93, and 116 m/s.

TABLE II
BOUNDARY CONDITIONS

Parameter	Values
Inlet Temperature	473 K
Gas Density	(Air defined as incompressible ideal gas)
Inlet Turbulence Density	10%
Inlet Hydraulic Diameter	0.0434 m
Outlet Pressure	101325 Pa (Atmospheric pressure)
Outlet Temperature	343 K
Outlet Turbulence Density	10%
Outlet Hydraulic Diameter	0.0434 m

IV. EXPERIMENTAL DATA

A. Acoustic Measurements

Transmission loss is the rate of sound pressure level incoming and outgoing from the muffler. It was expressed on frequency domain. Transmission loss is independent from the source and depends on the structure of the muffler. Equipments used for measuring transmission loss are:

- 4-Channel FFT Analyzer
- Pressure type microphone
- Power amplifier
- Adapter and connection pipes
- Sound source

Experimental setup and equipment are shown in Fig. 6. In the experimental set up, white noise signal produced by analyzer is transmitted to the source of the sound in order to generate the needed sound by amplifier. White noise which is generated by source is sent to the muffler. With four microphones that are placed in inlet and outlet of the muffler, sound pressure signals are collected during a period of time and these signals are converted to frequency domain with FFT after being amplified, and as a result auto-spectrum and cross-spectrum values are obtained. These data taken from the analyzer is processed by the computer and the transmission loss curves are obtained.

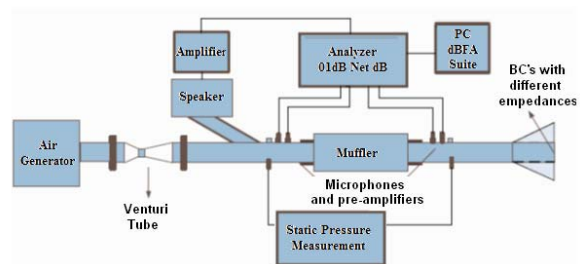

Fig. 6 Experimental setup

B. Flow Measurement

By measuring pressure at inlet and outlet of the muffler, pressure loss can be obtained at specific air flow rate. For this purpose, pressures sensors were placed at the experimental setup as shown in Fig. 6. While the transmitted signal was processed, it was delivered to the digital screen.

A blower connected to a motor was used to provide air and this blower was controlled with an AC frequency converter. The muffler was attached to the blower and pressure values were recorded.

V. RESULTS AND DISCUSSION

The comparison of experimental and numerical transmission loss results of the present muffler are shown in Fig. 7. It is commonly known that reactive mufflers are more effective in low frequency bandwidth. The cut-off frequency of the present muffler is approximately calculated as 1040 Hz with the equation of $f_c = 1.84c/(\pi d)$, where f_c is the cut of frequency, c is sound speed and d is the diameter of muffler. Therefore, the frequency axis of the attained graphs was cut at

this value.

Experimental results show three attenuation picks, which occur approximately between 0-900 Hz. These picks are results of the three expansion chambers within the muffler.

It can be said that numerical and experimental results are in good agreement. Minor discrepancies between these two results stem from small geometrical differences between the real muffler and CAD model.

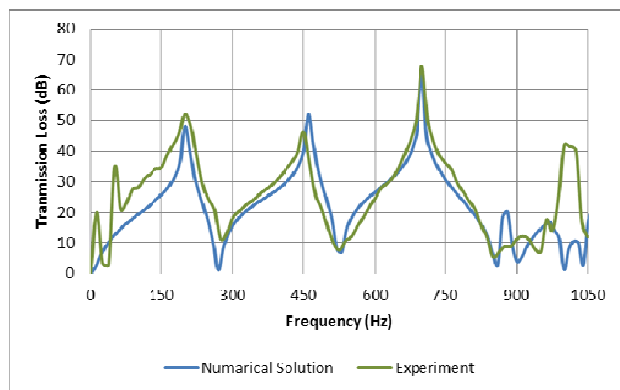

Fig. 7 Transmission loss

In numerical analysis, total acoustic pressure contours were obtained. In Fig. 8, acoustic pressure contours are shown on the cut-off frequency. It can be observed that axial resonances and transverse propagation modes are supported by the muffler at this frequency.

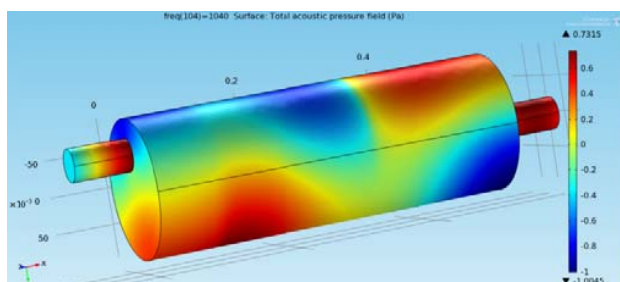

Fig. 8 Total acoustic pressure at 1040 Hz

The variation of back pressure with respect to volumetric flow rate is shown in Fig. 9. As shown in the Fig. 9, back pressure observed in numerical and experimental data increases with volumetric flow rate. Mean error is approximately 20%. Back pressure which occurred from gasoline engine is required to be maximum at 200 and 300 mbar. For the present muffler maximum back pressure is approximately 150 mbar and it is acceptable for the engine performance.

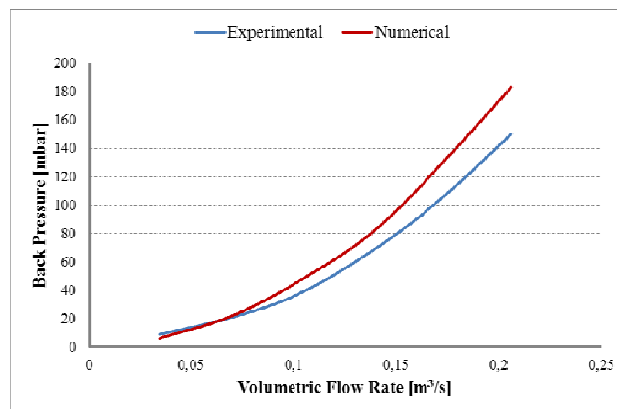

Fig. 9 Back pressure values vs. volumetric flow rate

VI. CONCLUSION

New regulations and standards for noise emission increasingly compel the automotive companies to make some improvements about decreasing the engine noise. Considering the cost and the volume of the muffler in the vehicle, the aim is to develop smaller and more compact designs without any loss from the back pressure in muffler. Proposed new designs should be analyzed with respect to both acoustics and back pressure.

In this study, a reactive perforated muffler is investigated. The present muffler was analyzed to obtain acoustic characteristic. The back pressure affects the engine performance directly an acoustic and flow analysis of the present muffler was examined and compared with experimental results.

Transmission loss values obtained from numerical analysis have shown a good agreement with the experimental results. Back pressure values from numerical analysis were calculated with a 20% margin of error. The results of this study will be used as a reference to be able to design new mufflers. So, prior to prototype manufacturing, which is a long and expensive process, different muffler designs can be examined numerically. By examining the effects on acoustic and flow characteristic of the muffler of each parameter, alternative muffler designs will be generated.

REFERENCES

- [1] Munjal, M. L.(1987). *Acoustic of Ducts and Mufflers*, John Wiley & Sons, New York.
- [2] Potente, Daniel.(2005). 'General Design Principles for an Automotive Muffler', Proceedings of ACOUSTICS 2005, Australia
- [3] Jin-Yong Mo, Man-Sun Huh,etc.(1994). 'A Study on the Analysis and Improvement of the Acoustic Characteristics of the Muffler with Complex Geometry', International Compressor Engineering Conference.
- [4] Panigrahi, S.N, Munjal, M.L. (2007). Backpressure considerations in designing of cross flow perforated-element reactive silencers, *Noise Control Eng. J.* 55 (6), 2007 Nov-Dec.
- [5] Fairbrother, R., Varhos, E. (2007) 'Acoustic Simulation of an Automotive Muffler with Perforated Baffles and Pipes', SAE Technical Paper Series, 2007-01-2206
- [6] Ji, Z.,Su S. Etc.(2008). 'Acoustic Attenuation Performance Analysis of Three-pass Perforated Tube Muffler with End-resonator', SAE Technical Paper Series, 2008-01-0894

- [7] Fang, J., Zhou, Y., Jiao, P., Ling, Z. (2009). 'Study on Pressure Loss for a Muffler Based on CFD and Experiment', 2009 International Conference on Measuring Technology and Mechatronics Automation.
- [8] Vishwakarma, A., Chandramouli, P. and Ganesan, V. (2009). 'Acoustic Analysis of Exhaust Muffler of a 4-Stroke Engine' SAE Technical Paper Series, 2009-01-1980
- [9] Hou, X., Guo, X., Liu, Z., Yan, F. and Peng, F. (2010). Flow Field Analysis and Improvement of Automobile Exhaust System Cold End, Computational Intelligence and Software Engineering, 2009.
- [10] Chen, J., Shi, X. (2011). CFD Numerical Simulation of Exhaust Muffler, 2011 Seventh International Conference on Computational Intelligence and Security
- [11] Kore, S., Aman, A. and Direbsa, E. (2011) 'Performance Evaluation Of A Reactive Muffler Using Cfd', Journal of EEA, Vol. 28, 2011
- [12] Vasile, O., Gillich, G. (2012). 'Finite Element Analysis Of Acoustic Pressure Levels And Transmission Loss Of A Muffler', 6th Wseas European Computing Conference (ECC '12), Prague.
- [13] FLUENT Users' Manual, FLUENT Inc, (2003).