

Structural Analysis of Warehouse Rack Construction for Heavy Loads

C. Kozkurt, A. Fenercioglu, M. Soyaslan

Abstract—In this study rack systems that are structural storage units of warehouses have been analyzed as structural with Finite Element Method (FEA). Each cell of discussed rack system storages pallets which have from 800 kg to 1000 kg weights and 0.80x1.15x1.50 m dimensions. Under this load, total deformations and equivalent stresses of structural elements and principal stresses, tensile stresses and shear stresses of connection elements have been analyzed. The results of analyses have been evaluated according to resistance limits of structural and connection elements. Obtained results have been presented as visual and magnitude.

Keywords—warehouse, structural analysis, AS/RS, FEM, FEA

I. INTRODUCTION

TODAYS production speed of industry improves as well as technological developments. Design process of a perfect automated storage and retrieval system (AS/RS) is unavoidable to support and develop qualified production. The system's structural design is the first step of the process. Structures can be designed and analyzed safer and faster via software analyses. These analyses guide to designer before production. Use of FEM software analyses is seen in many areas as articles and some of studies that involved about our study have been mentioned. Authors [1] analyzed beams, columns and connectors used in steel racks and conducted effective parameters like column thickness, connector depth and beam depth. Racks were analyzed as three dimensional and quality and cost which are optimized in [2]. Authors [3] judged analyses on components of heavy racks that are beam, pillar and brace. 2D analyses are realized to rack frame as linear, geometrical nonlinear geometrical and material nonlinear in [4]. Some authors researched specific material included rack construction elements as in [5] that authors analyzed semi rigid behavior of pultruded fibre reinforced plastic connectors with FEM and compared results with experimental works. In the literature research it is seen that generally beams, columns and connection elements are analyzed. [1]–[13]. In this work bolts and nuts were analyzed as supplementary work.

Rack system in this study has a suitable design with liquid food industry. Products can't be got out of warehouse directly to market after production in liquid food industry. Products have to be waited in incubation period for food safety.

C. Kozkurt is Research Assistant in the Faculty of Engineering and Natural Science, Gaziosmanpasa University, 60150, Tokat, TURKEY (phone: +90 356 252 1616 / 2815; e-mail: cemil.kozkurt@gop.edu.tr).

A. Fenercioglu is Assistant Professor in the Faculty of Engineering and Natural Science, Gaziosmanpasa University, 60150, Tokat, TURKEY (e-mail: ahmet.fenercioglu@gop.edu.tr).

M. Soyaslan is Research Assistant in the Faculty of Engineering and Natural Science, Gaziosmanpasa University, 60150, Tokat, TURKEY (e-mail: mucahit.soyaslan@gop.edu.tr).

This situation causes heavy loads to wait a long time in rack system and also materials to fatigue. Rack system must have high storage capacity and be tough to compensate intense production of the industry and store products rapidly.

Complete rack system has four floor, 30x60x6 m dimensions and can store 4800 pallets. The racks consist of two blocks that have a corridor between each other. Automated storage and retrieval system (AS/RS) used in the warehouse consists of two moving components. These are aisle robot that moves in corridor as two axes and shuttle that moves to aisle robot and into the rack system as one axis. Only shuttle mounts on the racks. Shuttle moves on sheet metal rails and stores or retrieves pallets on them. Rails constitute beams of the structure and transverse beams carry the rails. Transverse beams have been connected vertically to columns with connection elements. Bolts and nuts were used as connective elements in connection points. Briefly, rack system consists of six types of component which named rail (beam), column, prop, transverse beam, prop connection sheet and column – transverse beam connection element.

II. THEORETICAL FUNDAMENTALS

In this part, basis equations will be discussed which software used while FEM model of rack construction is being solved. Basis equation for stress-strain is given as (1). $\{\sigma\}$ signifies stress vector, $[D]$ signifies elastic stiffness matrix and $\{\epsilon^e\}$ signifies elastic strain vector. Three dimensional stress vector is given as (2).

$$\{\sigma\} = [D] \{\epsilon^e\} \quad (1)$$

$$\{\sigma\} = [\sigma_x \sigma_y \sigma_z \sigma_{xy} \sigma_{yz} \sigma_{xz}] \quad (2)$$

Three dimensional view of stress vector is shown in Fig. 1. The sign convention for direct stresses and strains used throughout the ANSYS program is that tension is positive and compression is negative. Principal stresses are calculated by cubic equation given as (3) from stress components.

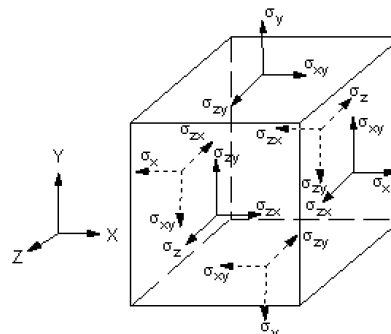

Fig. 1 Stress Vector

Three principal stresses are signified as $\sigma_1, \sigma_2, \sigma_3$. The principal stresses are ordered so that σ_1 is the most positive (tensile) and σ_3 is the most negative (compressive). Accordingly maximum tensile stress σ_1 is obtained from (3) which includes σ_0 principal stress with three values.

$$\begin{vmatrix} \sigma_x - \sigma_0 & \sigma_{xy} & \sigma_{yz} \\ \sigma_{xy} & \sigma_y - \sigma_0 & \sigma_{xz} \\ \sigma_{yz} & \sigma_{xz} & \sigma_z - \sigma_0 \end{vmatrix} = 0 \quad (3)$$

The Von Mises or equivalent stress σ_e is computed as (4) or (5).

$$\sigma_e = \left(\frac{1}{2} [(\sigma_1 - \sigma_2)^2 + (\sigma_2 - \sigma_3)^2 + (\sigma_3 - \sigma_1)^2] \right)^{\frac{1}{2}} \quad (4)$$

$$\sigma_e = \left(\frac{1}{2} [(\sigma_x - \sigma_y)^2 + (\sigma_y - \sigma_z)^2 + (\sigma_z - \sigma_x)^2] + 6(\sigma_{xy}^2 + \sigma_{yz}^2 + \sigma_{xz}^2) \right)^{\frac{1}{2}} \quad (5)$$

Maximum shear stress is obtained as (6) using Mohr's circle.

$$\tau_{\max} = \frac{\sigma_1 - \sigma_3}{2} \quad (6)$$

III. ASSUMPTIONS

Essential assumptions so that to accomplish FEM analyses are given below.

- 1) Ambient temperature is 22°C
- 2) Rack sizes are real dimensions in 3D model. Only one's symmetric part of frames that constitute all 3D model have been used in analysis to shorten preparing, meshing and solving times. This symmetric part is shown in Fig. 2.
- 3) Steel materials have been assumed as linear since elastic deformations are examined in analysis results.
- 4) Hexagon heads of bolts and nuts have been converted to circle to regularly divide meshing. Also fillets on the corners and edges of beams, columns and connection elements have been removed.

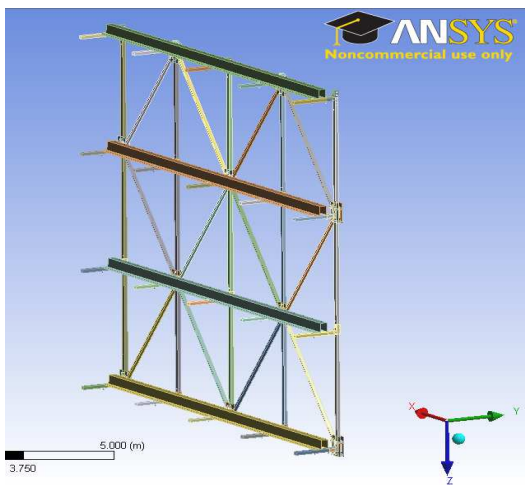

Fig. 2 Symmetric part of 3D One Frame Model

IV. 3D FRAME AS SOLID AND SHELL

Beams, columns and connection elements that have sheet structure designed as shell while 3D model were being drafted. SHELL181 element has used for the sheet regions. Geometry of SHELL181 is shown in Fig. 3. Thus analyses of mostly rack system's structural elements were solved in a shorter time.

Steel materials were defined as ST37 of which specifications is given in Table I.

Bolts and nuts were designed as solid. SOLID186 element of which geometry is shown in Fig. 2 was used for bolts and nuts. Also specifications of which used material for nuts and bolts are given in Table II.

Fig. 2 shows the geometry, node locations, and the element coordinate system for SHELL181 element. The element is defined by shell section information and by four nodes (I, J, K, and L).

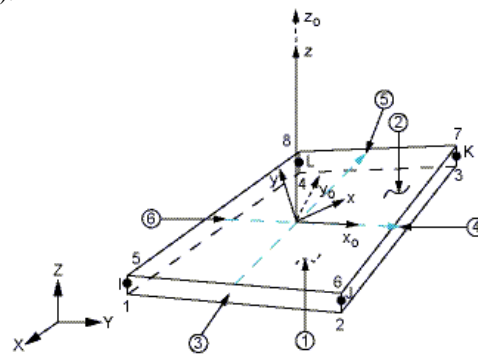

Fig. 2 SHELL 181 Geometry

Fig. 3 shows the geometry, node locations, and the element coordinate system for SOLID186 element. SOLID186 is a higher order 3-D 20-node solid element that exhibits quadratic displacement behavior. The element is defined by 20 nodes (I, J, K, L, M, N, O, P, Q, R, S, T, U, V, W, X, Y, Z, A, B) having three degrees of freedom per node, translations in the nodal x, y, and z directions. [6]

TABLE I
ST37 STRUCTURAL STEEL SPECIFICATIONS

Specification	Value	SI Unit
Yield Stress	230	MPa
Tensile (Breakage) Stress	415	MPa
Density	7850	Kg/m ³
Young Modulus	200,000	MPa
Poisson's Ratio	0.3	-

TABLE II
GALVANIZED STEEL BOLT /NUT SPECIFICATIONS

Specification	Value	SI Unit
Yield Stress	640	MPa
Tensile (Breakage) Stress	800	MPa
Density	7850	Kg/m ³
Young Modulus	200,000	MPa
Poisson's Ratio	0.3	-

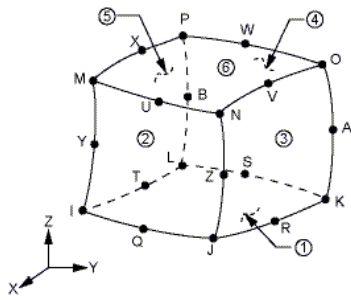

Fig. 3 SOLID186 Homogenous Structural Solid Geometry

V.FEM ANALYSES

A. Contacts

All contacts between elements were built as “No Separation”. Contact surface or edge was defined as shell element, target surface was defined as solid element in all shell-solid contacts. Face/Face and Face/Edge contacts were defined although Edge/Edge contacts were not defined.

B. Mesh

1,171,154 nodes were used in the model. “Hex Dominant Mesh Method” (HDMM) was used for bolts and nuts. The HDMM includes Element Midside Nodes and Free Face Mesh Type which determines the shape of the elements used to fill the body.

Mesh adaptation between structural elements and HDMM applied bolts is given in Fig. 5.

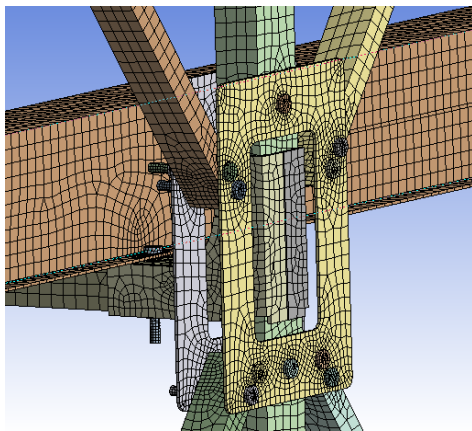

Fig. 5 HDMM Applied Bolts in Connection Area

C. Static Structural Analysis

Boundary Conditions:

Grate structured pallets mount on rails. Totally there is 3,250 kg load on upper surface of every rail. Loads and rail cross section are shown in Fig. 6. In addition, load effect of shuttle at storage or retrieval time was defined as 500 kg to complete full load condition. In this way that composing the worst scenario maximum deformation and stress values on the structure can be established. Mentioned loads applied to all rails as force.

Standard Earth Gravity was applied to structure with a view to own weight of structure. Structure was fixed to floor as shown in Fig. 7.

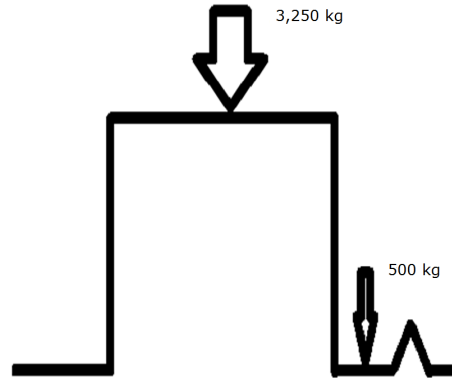

Fig. 6 Rail Cross-section and loads

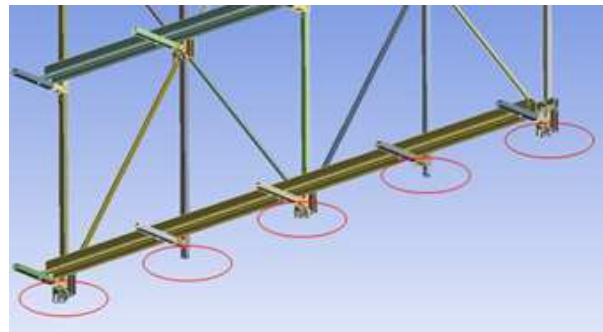

Fig. 7 Fixing Points of Rack Structure

1. Total Deformation:

The maximum deformation of the beams is 4.33 mm on the top of shelf. Result is total deformation and gives amount of flexion that is shown in Fig. 8. In view of the model is the height of 6 m full-load displacement ratio is 0.7 %.

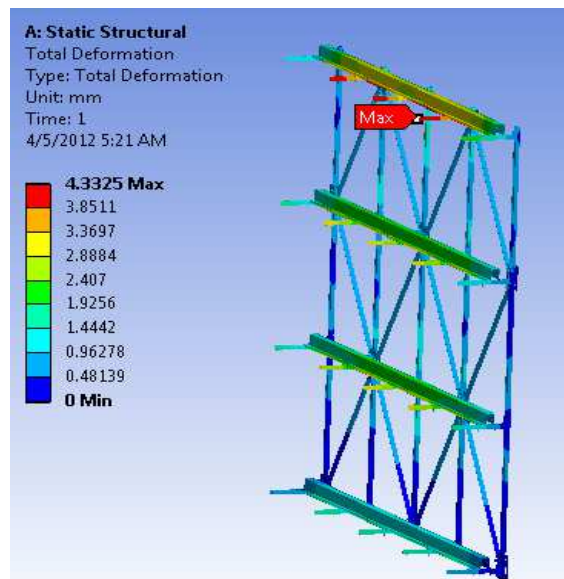

Fig. 8 Total Deformation of Rack Structure

2. Equivalent Stress

Maximum stress of structural elements is on the bottom bolt hole which passes a little yield stress and behaves as notch effect is given in Fig. 9. Yield resistance will increase because of regions that like this are hardened after loading. So using washers at the bottom floor gives an advantage.

Secondary high stresses are on the column – transverse beam connection elements on elliptical regions as shown in Fig. 10. Maximum stress in this region is 180 MPa and it is reliable according to 1.3 multiple yield.

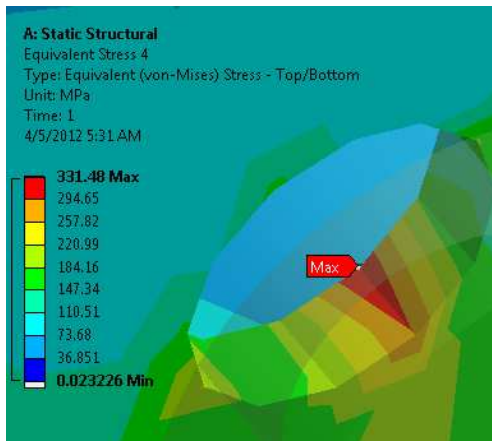

Fig. 9 Equivalent Stress Max Value Area

About 30 MPa stresses are seen on all of rails so thickness of these regions should be decrease a little. There are about 60 MPa stresses on the transverse beams which carry the rails. Also thickness of these regions should be decrease a little.

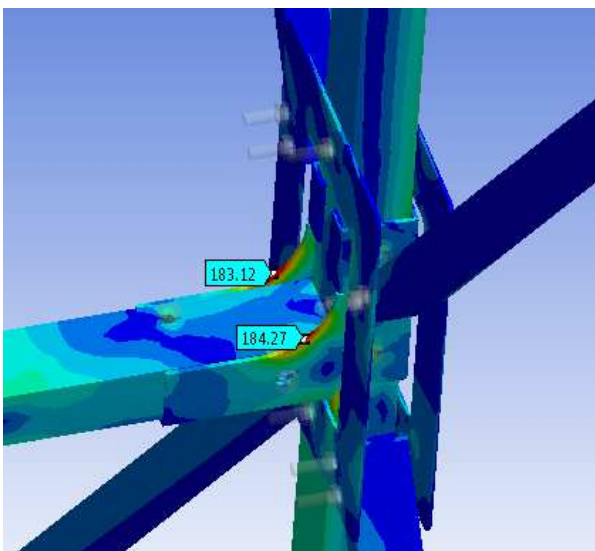

Fig. 10 Equivalent Stress Secondary High Value Area

3. Maximum Principal Stress (Tensile Stress)

There is 356 MPa maximum tensile stress on the bolts as given in Fig. 11. It is on bolt head and axle connection region of the simplified bolt. Little fillets are not solved in FEM analyses so that of to make more difficult the model.

Consequently, there won't be actual high magnitude because of fillet that did not modeled on this region. Even though this situation is the worst scenario bolts are safe considering to material of bolt.

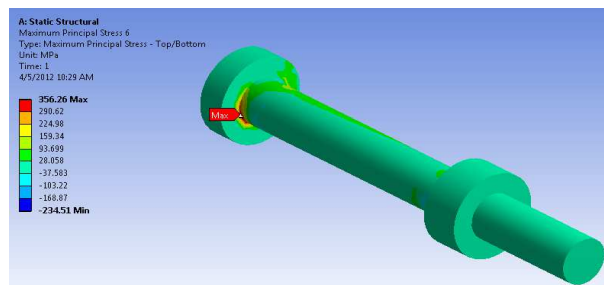

Fig. 11 Equivalent Stress Secondary High Value Area

4. Maximum Shear Stress:

Maximum shear stress is about 250 MPa on connection region of bolt and nut as shown in Fig. 12. This result is reliable considering to material of bolt.

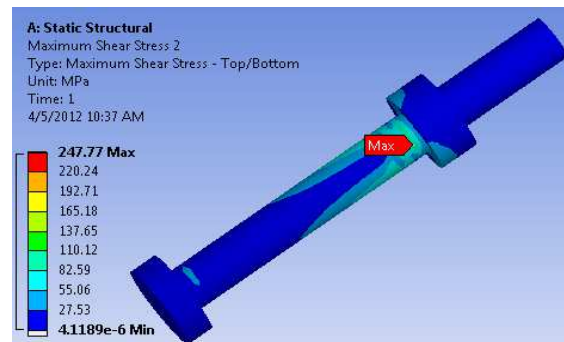

Fig. 12 Equivalent Stress Secondary High Value Area

VI. CONCLUSION

Maximum stress is seen on the holes that excavated for bolts as a result of analysis with defined boundary conditions. As linear material model was used, there is a local plastic deformation in that region. These results are not critical considering to FEM quality and hardening of the material in cyclic loadings.

On the other hand, intense stress distributions are seen on oval contour of column – transverse beam connection element. These stresses are reliable as 1.3 multiple.

Stress distributions and values on the bolts and nuts are reliable according to used material.

As a result of considering the entire model, analyses are provides boundary conditions so as loads.

ACKNOWLEDGMENT

This study is a work of project which is cooperated with DIMES and Gaziosmanpasa University. The project is supported by Republic of Turkey, Ministry of Science, Industry and Technology and DIMES Corporation (SAN-TEZ Project No: 00889.STZ.2011-1). This study is not official view of the Ministry.

REFERENCES

- [1] P. Prabha , V. Marimuthu, M. Saravanan and S. A. Jayachandran, "Evaluation of connection flexibility in cold formed steel racks," *Journal of Constructional Steel Research*, vol.66, pp. 863-872, 2010.
- [2] X. Zhao and J. Meng, "Three-Dimensional Finite Element Analysis Shelves," *Applied Mechanics and Materials*, vols. 117-119, pp. 639-642, 2011.
- [3] Y. Xie and Y. Huang, "FEA of heavy weight shelving based on ANSYS," *Mechanical Research & Application*, no. 5, pp. 85-86, 2005.
- [4] K. J. R. Rasmussen and B. P. Gilbert, "Dynamic Analysis of 2-D And 3-D Cold Formed Storage Rack," *School of Civil Engineering, The University of Sydney, Research Report R908, April 2010*, Sydney, Australia, pp.1-17.
- [5] A. V. Harte and D. Mc Cann, "Finite element modeling of the semi-rigid behavior of pultruded FRP connections," *Journal of Materials Processing Technology*, vol. 119, pp.98-103, 2001.
- [6] ANSYS Workbench 13.0 Help, *MechanicalAPDL // Theory Reference // 2. Structures*
- [7] A. Fenercioglu, M. Soyaslan and C. Kozkurt, "Automatic Storage And Retrieval System (AS/RS) Based On Cartesian Robot For Liquid Food Industry," in *12th International Workshop on Research and Education in Mechatronics, September 2011*, Kocaeli, Turkey, pp. 283-287.
- [8] M. Abdel-Jaber, R. G. Beale and M. H. R. Godley, "A theoretical and experimental investigation of pallet rack structures under sway," *Journal of Constructional Steel Research*, vol. 62, pp. 68-80, 2006.
- [9] Y. Zhu, C. Li, "Reliability Study of Beam and Plate Structures on Stochastic Finite Element Method," in *International Conference on Mechanical and Electrical Technology, September 2010*, Singapore, pp. 714-717.
- [10] F.D. Markazi, R.G. Beale, M.H.R. Godley, "Numerical modeling of semi-rigid boltless connectors," *Computers & Structures*, vol. 79, pp. 2391-2402, 2001.
- [11] M. H. R. Godley, R. G. Beale, X. Feng, "Analysis and design of down-aisle pallet rack structures," *Computers and Structures*, vol. 77, pp. 391-401, 2000.
- [12] I. Elkersh, "Experimental investigation of bolted cold formed steel frame apex connections under pure moment," *Ain Shams Engineering Journal*, vol. 1, pp. 11-20, 2010.
- [13] B. Calderoni, A. De Martino, A. Formisano and L. Fiorino "Cold formed steel beams under monotonic and cyclic loading: Experimental investigation," *Journal of Constructional Steel Research*, vol. 65 pp. 219-227, 2009.