

# Performance of a Transcritical CO<sub>2</sub> Heat Pump for Simultaneous Water Cooling and Heating

J. Sarkar, Souvik Bhattacharyya, and M. Ramgopal

**Abstract**—This paper presents the experimental as well as the simulated performance studies on the transcritical CO<sub>2</sub> heat pumps for simultaneous water cooling and heating; effects of water mass flow rates and water inlet temperatures of both evaporator and gas cooler on the cooling and heating capacities, system COP and water outlets temperatures are investigated. Study shows that both the water mass flow rate and inlet temperature have significant effect on system performances. Test results show that the effect of evaporator water mass flow rate on the system performances and water outlet temperatures is more pronounced (COP increases 0.6 for 1 kg/min) compared to the gas cooler water mass flow rate (COP increases 0.4 for 1 kg/min) and the effect of gas cooler water inlet temperature is more significant (COP decreases 0.48 for given ranges) compared to the evaporator water inlet temperature (COP increases 0.43 for given ranges). Comparisons of experimental values with simulated results show the maximum deviation of 5% for cooling capacity, 10% for heating capacity, 16% for system COP. This study offers useful guidelines for selecting appropriate water mass flow rate to obtain required system performance.

**Keywords**—CO<sub>2</sub> heat pump, experiment, simulation, performance characteristics.

## I. INTRODUCTION

RECENTLY, natural fluid CO<sub>2</sub> has been shown to be a promising alternative refrigerant particularly in heat pump applications due to gliding temperature heat rejection in the gas cooler and performance related various advantages. Some of the current theoretical and experimental investigations on several heat pump applications of transcritical CO<sub>2</sub> cycle have been presented by Neksa [1] and Kim et al. [2].

Neksa et al. [3] and White et al. [4] experimentally investigated the effects of discharge pressure, water inlet and outlet temperatures on the CO<sub>2</sub> heat pump water heater performances. Yarral et al. [5] experimentally investigated to effect of discharge pressure on CO<sub>2</sub> heat pump performance for simultaneous production of refrigeration and water heating to 90°C for the food processing industry. Adriansyah [6] experimentally studied the effect of discharge pressure for

simultaneous air-conditioning and water heating. Stene [7] presented the effect of water inlet temperature for combination of space and water heating. Cho et al. [8] studied the performance of the CO<sub>2</sub> heat pump by varying the refrigerant charge amount at standard cooling condition to show the importance of refrigerant charge to achieve better performance. Kim et al. [9] have done experimental study on CO<sub>2</sub> heat pump to study the effect of internal heat exchanger using water as secondary fluid for both sides with emphasizes only on heating. Sarkar et al. [10] numerically studied the effects of water inlet temperature, compressor speed and heat exchanger inventory for simultaneous water cooling and heating applications. Yokoyama et al. [11] numerically studied the influence of ambient temperature on performance of a CO<sub>2</sub> heat pump water heating system. Cabello et al. [12] experimentally studied the effect of evaporating temperature and gas cooler outlet temperature on optimum gas cooler pressure, and through comparisons with available correlations, showed that Sarkar et al. correlation [13] matches best with the test data. However, effects of water mass flow rate on heat pump behaviours are scarce.

In the present investigation, both simulation and experimental results on the working prototype of a transcritical CO<sub>2</sub> heat pump system for simultaneous water cooling and heating are presented. The cooling and heating capacities, system COP and water outlets temperatures have been studied for various water mass flow rates and water inlet temperatures of both evaporator and gas cooler. Comparison of simulated and experimental results is presented as well.

## II. EXPERIMENTS OF A TRANSCRITICAL CO<sub>2</sub> HEAT PUMP

### A. Description of test setup

Test facility layout of transcritical CO<sub>2</sub> heat pump for simultaneous water cooling and heating with instrumental positions is shown in Fig. 1. Stainless steel was chosen as the material for all system components. A Dorin CO<sub>2</sub> compressor (model TCS113: displacement = 2.2 m<sup>3</sup>/hr and capacity = 2.5 kW @ 2900 rpm) was chosen for the experimental investigation. On the basis of minimum and maximum pressure ratios of 80/50 and 120/26 (bar/bar), respectively, a Swagelok integral bonnet needle valve (model SS-1RS4) was used as the expansion device, which can be used regulate flow rate and degree of superheat. The separator and receiver were

J. Sarkar is with the Department of Mechanical Engineering, Institute of Technology-BHU, Varanasi, India 221005 (corresponding author: Tel: 91-9919787557; Fax: 91-542-2368157; E-mail: jahar\_s@hotmail.com).

Souvik Bhattacharyya is with the Department of Mechanical Engineering, Indian Institute of Technology, Kharagpur India 721302 (e-mail: souvik@mech.iitkgp.ernet.in).

M. Ramgopal is with the Department of Mechanical Engineering, Indian Institute of Technology, Kharagpur India 721302.

designed for a total volumetric capacity of 8 L and 2 L, respectively. A condensing unit including a fan and a storage tank was employed for a maximum heat transfer rate of 6 kW to cool the warm water to its initial temperature at the inlet to the gas cooler. A water bath with heater and pump was incorporated in the evaporator to supply water at constant temperature and flow rate. The evaporator and the gas cooler are counter-flow tube-in-tube heat exchangers, where CO<sub>2</sub> flows in the inner tube and water in the outer annulus (Table I). Measuring ranges of instruments with uncertainties are listed in Table II.

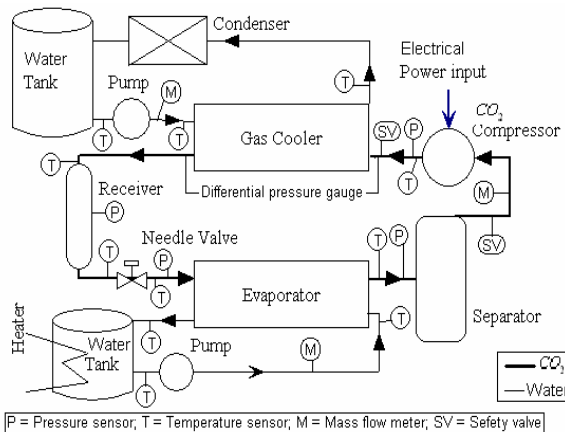

Fig. 1 Test facility layout of the transcritical CO<sub>2</sub> heat pump

TABLE I  
DIMENSIONS OF GAS COOLER AND EVAPORATOR

Heat exchangers	Gas cooler	Evaporator
Configuration	Coaxial, Single pass, 14 rows	Coaxial, Single pass, 9 rows
Inner tube OD/outer tube OD	6.35 mm/12 mm	9.5mm/16mm
Total length of tubing	14 m	7.2 m

### B. Test procedure and test conditions

In the experimental study, the effects of water inlet temperature and mass flow rate in gas cooler, and water inlet temperature and mass flow rate in evaporator were investigated by varying them using condensing unit for the gas cooler and heating unit for the evaporator. Constant suction pressure and discharge pressure were maintained by simultaneous control of the total mass of CO<sub>2</sub> in the system and degree of opening of the expansion device. The total refrigerant mass in the system was controlled by adding CO<sub>2</sub> from a high pressure cylinder or by venting it through the safety valve. For certain test conditions, constant water flow rates for both evaporator and gas cooler were maintained by pumps, water inlet water temperature to gas cooler was maintained by controlling fan speed and water inlet temperature to evaporator was maintained by heater control. The compressor power input was measured by using a power meter, the refrigerant mass flow rate was measured by a

Coriolis effect flow meter, the pressure of the refrigerant were monitored by using pressure transducers, pressure drop in the heat exchangers was measured by differential pressure transducer and refrigerant and water temperatures at all required locations were measured by using T-type & K-type thermocouples. All the measurements have been done at steady state condition. The principal system performance parameters under steady state, namely, power input to the compressor, cooling capacity, heating capacity, system COP have been computed from the measured data. The uncertainties of cooling capacity, heating capacity and system COP, estimated by error analysis, are approximately  $\pm 5\%$ ,  $\pm 5\%$  and  $\pm 6\%$ , respectively.

TABLE II  
RANGES AND UNCERTAINTIES OF MEASURING INSTRUMENTS

Parameters	Measuring instruments	Ranges	Accuracy
Pressure	Dial pressure gauge	0-160 bar	$\pm 1.5\%$ of full range
Pressure loss	Differential pressure gauge	0-4 bar	$\pm 1.5\%$ of full range
CO <sub>2</sub> mass flow rate	Mass flow meter	0.2-10 kg/min	$\pm 0.1\%$ of full range
Water mass flow rate	Mass flow meter	0.5-20 kg/min	$\pm 0.5\%$ of full range
Temperature	Thermocouples (T-type, K-type)	Calibrated range: 0-150 °C	$\pm 0.5$

### III. SIMULATION OF TRANSCRITICAL CO<sub>2</sub> HEAT PUMP

The simulated carbon dioxide based heating and cooling system consists of compressor, expansion valve, evaporator and gas cooler. Water is taken as secondary fluid for both gas cooler and evaporator to give the useful cooling and heating outputs. Both these heat exchangers are of double-pipe counter flow type, where the refrigerant flows through the inner tube and water flows through the outer annular space. The layout and corresponding temperature-entropy diagram with water flow lines is shown in Fig. 2.

The entire system has been modeled based on energy balance of individual components yielding conservation equations presented below. The following assumptions have been made in the analysis:

1. Heat transfer with the ambient is negligible.
2. Only Single-phase heat transfer occurs for water (external fluid).
3. Compression process is adiabatic but not isentropic.
4. Pressure drop on waterside and in connecting pipes are negligible.
5. Changes in kinetic and potential energies are negligible.
6. Refrigerant is free from oil.

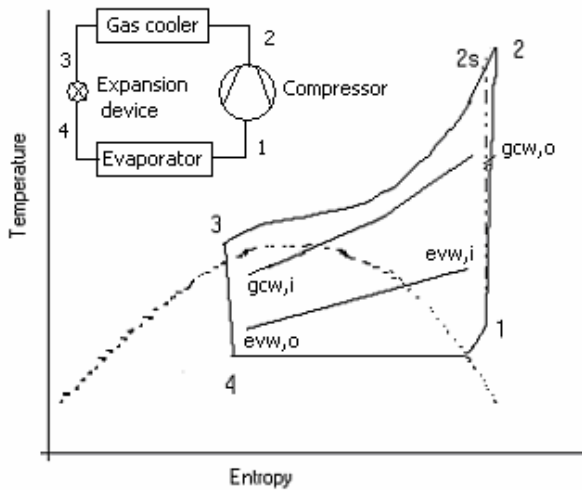

Fig. 2 Temperature-entropy diagram of a transcritical  $CO_2$  heat pump

#### A. Compressor model

The refrigerant mass flow rate through the compressor is given by,

$$\dot{m}_r = \rho_1 \eta_v V_s \frac{N}{60} \quad (1)$$

The following correlations have been used for volumetric and isentropic efficiencies respectively for the semi-hermetic compressor, which have obtained based on regression of manufacturer test data, neglecting the effect of degree of superheat:

$$\eta_v = 1.1636 - 0.2188 \left( \frac{P_{dis}}{P_{suc}} \right) + 0.0163 \left( \frac{P_{dis}}{P_{suc}} \right)^2 \quad (2)$$

$$\eta_{is,c} = 0.61 + 0.0356 \left( \frac{P_{dis}}{P_{suc}} \right) - 0.0257 \left( \frac{P_{dis}}{P_{suc}} \right)^2 + 0.0022 \left( \frac{P_{dis}}{P_{suc}} \right)^3 \quad (3)$$

#### B. Gas cooler model

To consider the lengthwise property variation, gas cooler has been discretized into equal length segments along the refrigerant flow direction and momentum and energy conservation equations have been applied to each segment [9-10]. Employing LMTD expression, heat transfer in  $i^{th}$  segment of the gas cooler is given by,

$$Q_{gc}^i = (UA)_{gc}^i \frac{(T_{gcr}^i - T_{gcw}^i) - (T_{gcr}^{i+1} - T_{gcw}^{i+1})}{\ln \left( \frac{T_{gcr}^i - T_{gcw}^i}{T_{gcr}^{i+1} - T_{gcw}^{i+1}} \right)} \quad (4)$$

Additionally, energy balance in segment of gas cooler for both the fluids yield:

$$Q_{gc}^i = \dot{m}_r (h_{gcr}^i - h_{gcr}^{i+1}) = \dot{m}_{gcw} c_{pw} (T_{gcw}^i - T_{gcw}^{i+1}) \quad (5)$$

The overall heat transfer coefficient for the segment of gas cooler has been calculated using the fundamental equation for overall heat transfer coefficient.

To estimate the heat transfer coefficient of supercritical carbon dioxide for in-tube cooling in gas cooler, Pitla et al. [14] correlation, incorporating both bulk and wall properties due to large variation of fluid properties in the radial direction, has been used. The pressure drop for supercritical carbon dioxide in-tube cooling has been calculated by Petrov and Popov equation [15], neglecting inertia effect. The waterside heat transfer coefficient has been evaluated by the Gnielinski [16] equation for annular flow. All water properties are assumed to be temperature dependent only, and polynomial expressions based on text book values have been used.

#### C. Evaporator Model

The evaporator consists of two zones: two-phase (boiling) zone and superheated zone. Similar to the gas cooler, both zones in the evaporator are divided into a finite number of equal-length segments along the refrigerant flow direction. Each segment is treated as one counter-flow heat exchanger and the outlet conditions of each segment should become inlet conditions for the next segment. For each segment LMTD method is used and properties are evaluated based on mean temperature and pressure. Energy balance in each segment of the evaporator for the refrigerant ( $CO_2$ ) and water, respectively, yields:

$$Q_{ev}^i = \dot{m}_r (h_{evr}^{i+1} - h_{evr}^i) = \dot{m}_{evw} c_{pw} (T_{evw}^{i+1} - T_{evw}^i) \quad (6)$$

The overall heat transfer coefficient for each segment of the evaporator has been calculated in the same way as for the gas cooler. In this analysis, the recently developed Yoon et al. [17] correlation has been employed to estimate the boiling heat transfer coefficient. For superheated zone, Gnielinski [16] equation has been used to estimate convective heat transfer coefficient of carbon dioxide. Jung and Radermacher [18] correlation has been used for boiling pressure drop and Blasius correlation has been used for single phase pressure drop of carbon dioxide. The waterside heat transfer coefficient has been evaluated by Gnielinski [16] equation for annular flow for both two-phase and superheated sections.

Using discretization, the heat exchanger is made equivalent to a number of counter flow heat exchangers arranged in series and the combined heat transfer of all the segments is the total heat transfer of the heat exchanger. Therefore, fast changing properties of  $CO_2$  have been modeled accurately in both evaporator and gas cooler.

#### D. Expansion Device Model

The expansion process is considered to be isenthalpic under the assumption that the heat exchange with its surroundings is negligible, yielding:

$$h_4 = h_3 \quad (7)$$

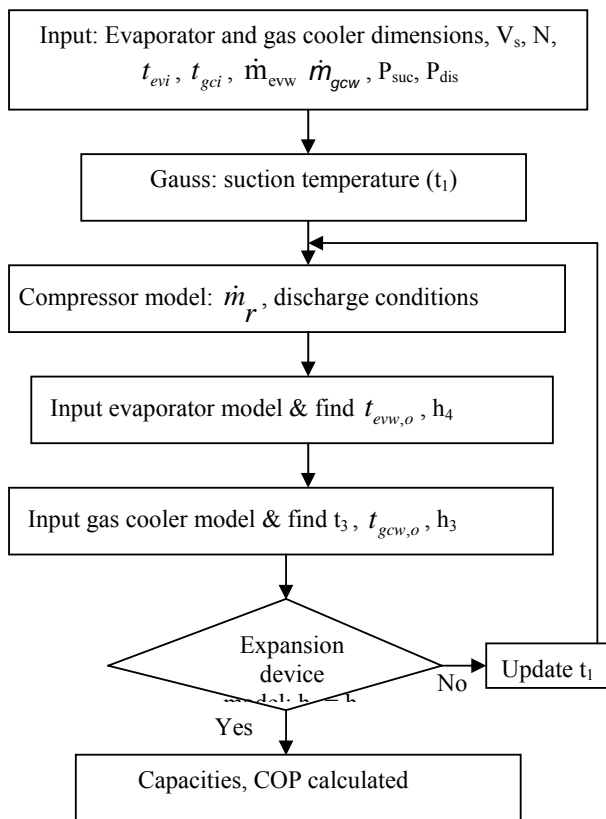

Fig. 3 Flow-chart for the simulation model

#### E. Numerical Procedure

A computer code, incorporating the subroutine 'CO2PROP' [10] for thermophysical and transport properties, has been developed to simulate the transcritical carbon dioxide system for simultaneous water cooling and heating at various operating conditions. Water inlet temperatures and water mass flow rates for both heat exchangers, compressor data, evaporator and gas cooler dimensions, compressor suction pressure and discharge pressure are the input data for the simulation.

The flow chart of the simulation is shown in Fig. 3. Pressure drop and heat loss in connecting lines are not considered; therefore, the outlet state of one component becomes the inlet state of the next component. In the simulation, by assuming the suction temperature, refrigerant mass flow rate and compressor outlet conditions are calculated by compressor model, and refrigerant conditions at evaporator inlet and at gas cooler outlet as well as water outlet temperatures of both evaporator and gas cooler are calculated based on mathematical model of evaporator and gas cooler. The suction temperature is adjusted by the iteration in order for the enthalpy of inlet ( $h_3$ ) and outlet ( $h_4$ ) of expansion valves to converge within a prescribed tolerance and performances such as cooling and heating capacities, compressor work and COP are calculated. Tolerance has been maintained in the range of  $10^{-3}$  for simulation.

#### IV. RESULTS AND DISCUSSION

The performance of the CO<sub>2</sub> heat pump system in terms of cooling and heating capacities and system COP (cooling + heating capacities divided by compressor power) considering both cooling and heating as useful outputs are studied for the suction and discharge pressure of 40 bar and 90 bar, respectively. Both the numerical and experimental results are presented to study the effect of water inlet temperatures and mass flow rates on the performances and water outlet temperatures.

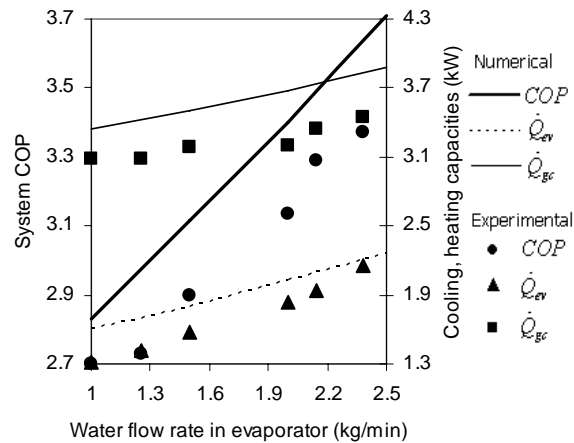

Fig. 4 System performance variation with evaporator water flow rate

Effects of water mass flow rate to evaporator on the performances and water outlet temperatures for both gas cooler and evaporator are shown in Figs. 4 and 5, respectively, for evaporator water inlet temperature of 29°C, gas cooler water inlet temperature of 33°C and water mass flow rate of 1 kg/min. With increase in water mass flow rate to evaporator, the cooling capacity increases due to increase in water side heat transfer coefficient and both the heating capacity and compressor work increase modestly due to minor increase in the suction temperature (increase in degree of superheat) and also discharge temperature. Water outlet temperature of evaporator increases due to dual effect of increase in cooling capacity and water mass flow rate; whereas water outlet temperature of gas cooler increases due to increase in heating capacity.

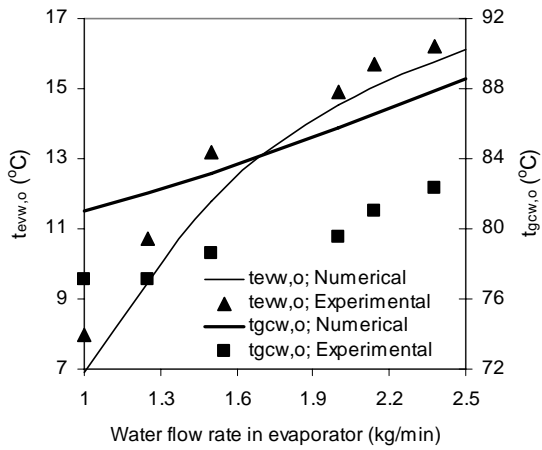

Fig. 5 Water outlet temperature variation with evaporator water flow rate

0.6 per 1 kg/min) compared to the effect of water mass flow rate in gas cooler (COP increases about 0.4 per 1 kg/min).

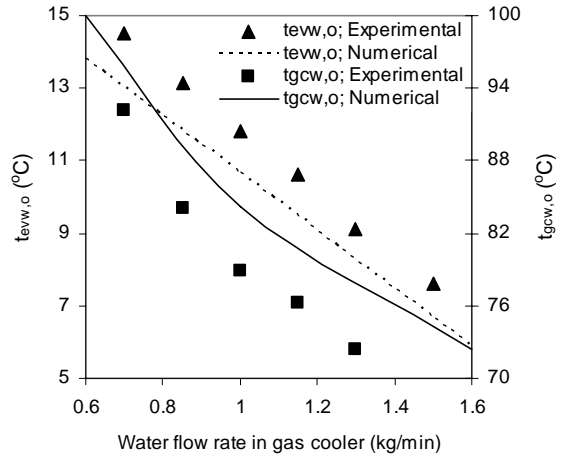

Fig. 7 Variation of water outlet temperatures with gas cooler water flow rate

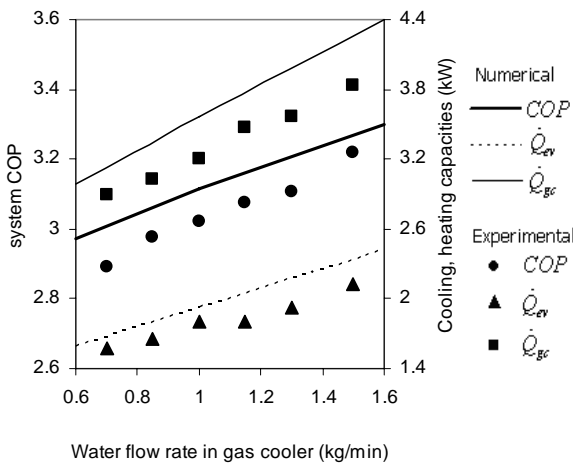

Fig. 6 Variation of system performance with gas cooler water flow rate

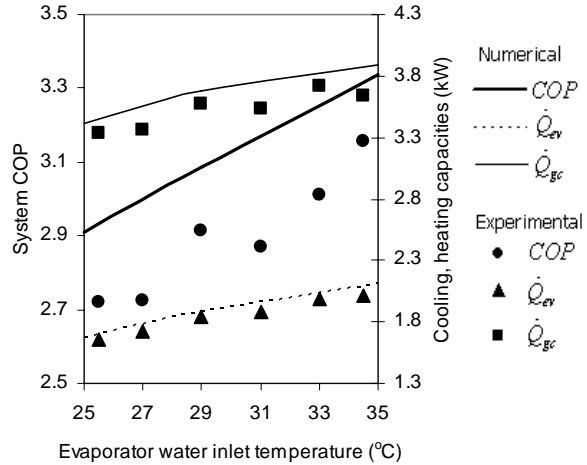

Fig. 8 Variation of system performance with evaporator water inlet temperature

Effects of water mass flow rate to gas cooler on the performances and water outlet temperatures for both gas cooler and evaporator are shown in Figs. 6 and 7, respectively, for gas cooler water inlet temperature of 33°C, evaporator water inlet temperature of 29°C and water mass flow rate of 1.5 kg/min. With increase in water mass flow rate in gas cooler, heating output increases modestly due to increase in water side heat transfer coefficient and refrigerant mass flow rate increases, which enhances the cooling capacity, although the effect on compressor work is insignificant and hence the system COP increases. Due the dual effect of increase in water mass flow rate and heating capacity, the water outlet temperature of gas cooler decreases and evaporator water outlet temperature decreases due to increase in cooling capacity with increase in water mass flow rate in gas cooler. Results show that the effect of water flow rate in evaporator is more pronounced on the performances (COP increases about

Figs. 8 and 9 exhibit the variations of performances and water outlet temperatures with evaporator water inlet temperature for mass flow rates of water in gas cooler and evaporator of 1 kg/min and 1.5 kg/min respectively, and water inlet temperature to gas cooler of 33°C. With the increase in water inlet temperature to evaporator, suction temperature as well as discharge temperature increases, which enhance both cooling and heating capacities; however compressor work increases insignificantly due to decrease in refrigerant mass flow rate and hence system COP increases. Water outlet temperature of evaporator increases due to dual effect of increase in cooling capacity and water inlet temperature; whereas water outlet temperature of gas cooler increases due to increase in heating capacity.

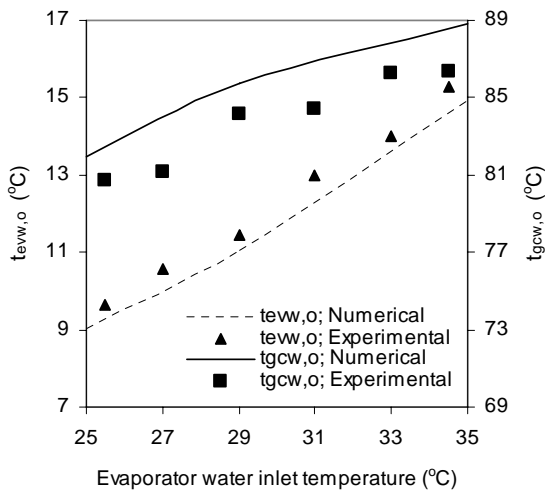

Fig. 9 Water outlet temperature variation with evaporator water inlet temperature

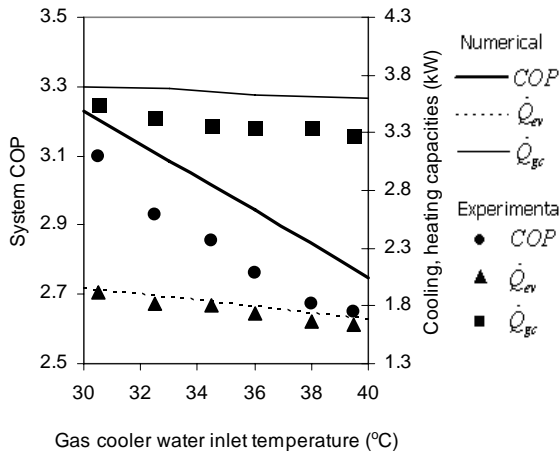

Fig. 10 Variation of system performance with gas cooler water inlet temperature

Figs. 10 and 11 exhibit the variations of performances and water outlet temperatures with water inlet temperature to gas cooler for mass flow rates of water in gas cooler and evaporator of 1 kg/min and 1.5 kg/min respectively, and water inlet temperature to evaporator of 29°C. As the water inlet temperature to gas cooler increases, the heating capacity decreases due to deterioration in heat transfer properties of CO<sub>2</sub> in gas cooler and the refrigerant exit temperature in gas cooler increases, which increases the vapor quality in evaporator inlet and hence cooling output also decreases, however, compressor work is nearly invariant due to negligible change in refrigerant mass flow rate and degree of superheat and hence system COP decreases significantly. Due the dual effect of increase in water inlet temperature and decrease in heating capacity, the water outlet temperature of

gas cooler increases and evaporator water outlet temperature increases due to decrease in cooling capacity with increase in water inlet temperature to gas cooler. Results show that the effect of water inlet temperature to gas cooler on the system performances is more significant (COP decreases about 0.48 per 10°C) compared to the effect of water inlet temperature to evaporator (COP increases about 0.43 per 10°C water inlet temperature).

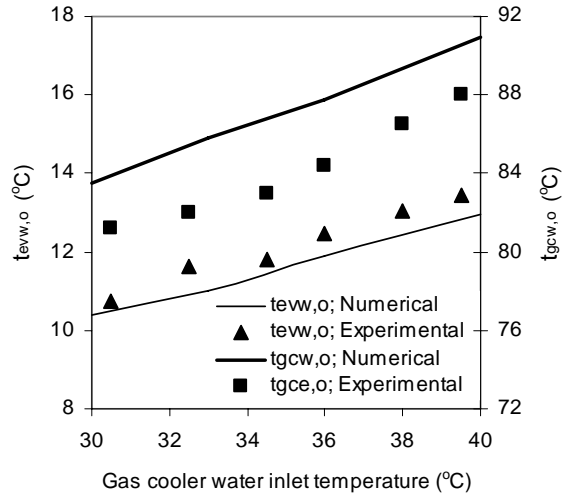

Fig. 11 Water outlet temperature variation with gas cooler water inlet temperature

Results show that the test values of heating capacity is lower than the simulated values with maximum deviation of 5%, test values of heating capacity are lower than the simulated values with maximum deviation of 10% and experimental values of COP is lower than the simulated values with maximum deviation of 16%. Results show that the test values of water outlet temperature to evaporator are higher than the simulated values with maximum deviation of 12% and that is lower in case of gas cooler with maximum deviation of 7.5%. It may be noted that the suction pressure is maintained constant by varying degree of superheat unlike to the previous studies [9-10] and the superheat values varied from 5°C to 15°C in the simulation and 8°C to 20°C in the test for given ranges.

## V. CONCLUSIONS

Both simulation and experimental studies on a transcritical CO<sub>2</sub> heat pump system for simultaneous water cooling and heating have been carried out to study the system performances and water outlet temperatures for various mass flow rates and water inlet temperatures for both evaporator and gas cooler. The cooling and heating capacities and COP increase with increase in water mass flow rate to both evaporator and gas cooler; however, effect is more pronounce in case of evaporator mass flow rate (COP increases by 0.6 per 1 kg/min, whereas 0.4 for gas cooler mass flow rate).

Evaporator and gas cooler water outlet temperatures increase with increase in evaporator mass flow rate and decrease with increase in evaporator mass flow rate. Cooling and heating capacities and COP increase with increase in water inlet temperature to evaporator, whereas trends are opposite with increase in gas cooler water inlet temperature; effect of gas cooler water inlet temperature is more pronounce (COP increases by 0.48 per 10°C, whereas 0.43 for gas cooler). With the increase in water inlet temperatures to both evaporator and gas cooler, water outlet temperatures of both evaporator and gas cooler increase. Comparison of simulated and experimental values showed the maximum deviation of 5% for cooling capacity, 10% for heating capacity, 16% for system COP, 12% and 7.5% for water outlet temperatures of evaporator and gas cooler, respectively. The present study offers useful guidelines for suitable system design and will help choose suitable water mass flow rates for required system performance and water outlet temperatures.

#### ACKNOWLEDGMENT

The financial support extended by Ministry of Human Resource and Development, Government of India is gratefully acknowledged.

#### NOMENCLATURE

$c_p$	specific heat capacity (kJ/kgK)
$h$	specific enthalpy (kJ/kg)
$\dot{m}$	mass flow rate (kg/min)
$N$	compressor speed (rpm)
$P$	pressure (bar)
$\dot{Q}$	heat rate (kW)
$t, T$	temperature (°C, K)
$UA$	heat conductance (W/K)
$V_s$	suction volume (m <sup>3</sup> )
$\eta$	efficiency
$\rho$	density (kg/m <sup>3</sup> )

#### Subscripts

dis	discharge
ev	evaporator
gc	gas cooler
i	inlet
o	outlet
r	refrigerant
suc	suction
w	water

#### REFERENCES

- [1] P. Neksa, "CO<sub>2</sub> heat pump systems," *Int. Journal of Refrigeration*, vol. 25, no. 4, pp. 421-427, June 2002.
- [2] M. H. Kim, J. Pettersen, and C. W. Bullard, "Fundamental process and system design issues in CO<sub>2</sub> vapor compression systems," *Progress in Energy and Combustion Science*, vol. 30, no. 2, pp. 119-174, 2004.
- [3] P. Neksa, H. Rekstad, G. R. Zakeri, and P. A. Schiefloe, "CO<sub>2</sub> heat pump water heater: characteristics, system design & experimental results," *Int. Journal of Refrigeration*, vol. 21, no. 3, pp. 172-179, May 1998.

- [4] S. D. White, M. G. Yarrall, D. J. Cleland, and R. A. Hedley, "Modelling the performance of a transcritical CO<sub>2</sub> heat pump for high temperature heating," *Int. Journal of Refrigeration*, vol. 25, no. 4, pp. 479-486, June 2002.
- [5] M. G. Yarrall, S. D. White, D. J. Cleland, R. D. S. Kallu, and R. A. Hedley, "Performance of transcritical CO<sub>2</sub> heat pump for simultaneous refrigeration and water heating," *XX Int. Congress of Refrigeration*, Sydney, 1999, Paper no. 651.
- [6] W. Adriansyah, "Combined air conditioning and tap water heating plant using CO<sub>2</sub> as refrigerant," *Energy and Buildings*, vol. 36, no. 7, pp. 690-695, July 2004.
- [7] J. Stene, "Residential CO<sub>2</sub> heat pump system for combined space heating and hot water heating," *Int. Journal of Refrigeration*, vol. 28, no. 8, pp. 1259-1265, Dec. 2005.
- [8] H. Cho, C. Ryu, Y. Kim, and H. Y. Kim, "Effects of refrigerant charge amount on the performance of a transcritical CO<sub>2</sub> heat pump," *Int. Journal of Refrigeration*, vol. 28, no. 8, pp. 1266-1273, Dec. 2005.
- [9] S. G. Kim, Y. J. Kim, G. Lee, and M. S. Kim, "The performance of a transcritical CO<sub>2</sub> cycle with an internal heat exchanger for hot water heating," *Int. Journal of Refrigeration*, vol. 28, no. 7, pp. 1064-1072, Nov. 2005.
- [10] J. Sarkar, S. Bhattacharyya, and M. Ramgopal, "Simulation of a transcritical CO<sub>2</sub> heat pump cycle for simultaneous cooling and heating applications," *Int. Journal of Refrigeration*, vol. 29, no. 5, pp. 735-743, Aug. 2006.
- [11] R. Yokoyama, T. Shimizu, K. Ito, and K. Takemura, "Influence of ambient temperatures on performance of a CO<sub>2</sub> heat pump water heating system," *Energy*, vol. 32, no. 4, pp. 388-398, Apr. 2007.
- [12] R. Cabello, D. Sa'nchez, R. Llopis, and E. Torrella, "Experimental evaluation of the energy efficiency of a CO<sub>2</sub> refrigerating plant working in transcritical conditions," *Applied Thermal Engineering*, vol. 28, no. 13, pp. 1596-1604, Sep. 2008.
- [13] J. Sarkar, S. Bhattacharyya, and M. RamGopal, "Optimization of a transcritical CO<sub>2</sub> heat pump cycle for simultaneous cooling and heating applications," *Int. Journal of Refrigeration*, vol. 27, no. 8, pp. 830-838, Dec. 2004.
- [14] S. S. Pitla, E. A. Groll, and S. Ramadhyani, "New correlation to predict the heat transfer coefficient during in-tube cooling of turbulent supercritical CO<sub>2</sub>," *Int. Journal of Refrigeration*, vol. 25, no. 6, pp. 887-895, Sep. 2002.
- [15] X. Fang, C. W. Bullard, and P. S. Hrnjak, "Heat transfer and pressure drop of gas coolers," *ASHRAE Transactions*, vol. 107, pp. 255-266, 2001.
- [16] V. Gnielinski, "New equations for heat and mass transfer in turbulent pipe and channel flow," *Int. Chemical Engineering*, vol. 16, pp. 359-366, 1976.
- [17] S. H. Yoon, E. S. Cho, Y. W. Hwang, M. S. Kim, K. Min, and Y. Kim, "Characteristics of evaporative heat transfer and pressure drop of carbon dioxide and correlation development," *Int. Journal of Refrigeration*, vol. 27, no. 2, pp. 111-119, Mar. 2004.
- [18] D. S. Jung, and R. Radermacher, "Prediction of pressure drop during horizontal annular flow boiling of pure and mixed refrigerants," *Int. Journal of Heat Mass Tran.*, vol. 32, no. 12, 2435-2466, Dec. 1989.

**J. Sarkar** received his M. Tech. and Ph.D. degrees in Mechanical Engineering from Indian Institute of Technology Kharagpur, India in 2001 and 2006, respectively. After, he joined the faculty of Institute of Technology, Banaras Hindu University, India and working as a Lecturer in Mechanical Engineering Department till date. Author has published 30 research papers in international journal and 20 in national and international conferences in several areas of Heat Transfer and Refrigeration.