

# A Study of Wind Speed Characteristic in PI Controller based DFIG Wind Turbine

T. Unchim and A. Oonsivilai

**Abstract**—The Wind Turbine Modeling in Wind Energy Conversion System (WECS) using Doubly-Fed Induction Generator (DFIG) PI Controller based design is presented. To study about the variable wind speed. The PI controller performs responding to the dynamic performance. The objective is to study the characteristic of wind turbine and finding the optimum wind speed suitable for wind turbine performance. This system will allow the specification setting (2.5MW). The output active power also corresponding same the input is given. And the reactive power produced by the wind turbine is regulated at 0 Mvar. Variable wind speed is optimum for drive train performance at 12.5 m/s (at maximum power coefficient point) from the simulation of DFIG by Simulink is described.

**Keywords**—DFIG, wind speed, PI controller, the output power.

## I. INTRODUCTION

THE wind energy is clean energy, an alternative or renewable energy for the electricity generation. Its can replace the fuel that may be empty in the future. Therefore, the wind energy is another alternative for research and development into the more available.

The wind is a natural phenomenon from many causes; temperature differences, atmospheric pressure and the earth rotation force. These factors create the wind speed and power. It is accepted that wind is a form of energy within itself, sometimes its severe force may damage even residences, uproot trees, carry items over distances, etc. Presently, people give significances to wind energy for more utilization due to it being an abundant, clean, environmental friendly, non-depleted and free energy resource [1].

Wind energy is converted into electricity by using wind turbines. Mechanical machinery converts the kinetic energy from the wind movement to the mechanical energy for direct utilization. The wind turbine has been developed for applications continuously and is pursued up to nowadays.

In this paper, we study about the control systems in DFIG model [2], constitute the mainstream configuration for the wind turbines in the research activity. That is the simulation by Simulink to finding the optimum point of the wind speed.

T. Unchim is with the Smart Materials, Health Sciences and Energy Research Center and the Alternative and Sustainable Energy Research Unit, School of Electrical Engineering, Suranaree University of Technology, Nakhon Ratchasima, Thailand. (e-mail: tapekung13th@hotmail.com)

A. Oonsivilai, corresponding author, is with Center of Excellence in Electric Energy, Smart Materials, and Health Science, Postharvest Technology Research Center, School of Electrical Engineering, Institute of Engineering, Suranaree University of Technology, Nakhon Ratchasima, 30000 Thailand. (phone: 66-81-548-7728, fax: 66-44-224601; e-mail: anant@sut.ac.th)

This paper is organized as following; Section II describes about the wind energy systems consistency to the output power, the coefficient and the tip-speed ratio characteristic. DFIG model and control strategy by PI controller [3-7] explained in Section III and IV, respectively.

In Section V is the simulation result, the specification reference to The Lumtakhong wind power plant in Nakhon Ratchasima, Thailand [8]. Final conclusion in section VI.

## II. THE WIND ENERGY SYSTEMS

The process of WECS transforms wind into mechanical energy by wind turbine blades and, ultimately, into electrical energy through the generator.

The general wind farm consists of combination each the wind turbines. That can be used as energy sources for produced electricity into grid systems.

The wind turbine based on DFIG scheme as shown in Fig. 1[8], the component in each part, as the wind turbine (include the gear box), induction generator, voltage source converter (both rotor and grid side into detailed section III and IV) for control the systems and the electrical grid.

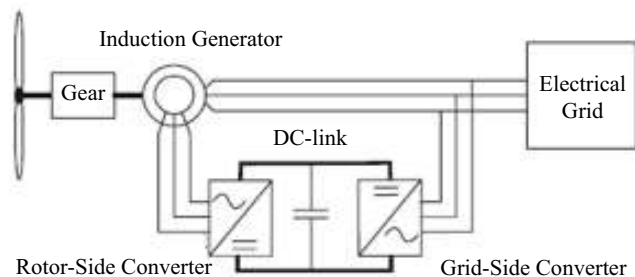

Fig. 1 The scheme of the wind generation

The energy produced from the wind turbines converting and depends on wind speeds, although not directly proportional. At low wind speeds (about 1-3 m/s), the wind turbine will not function (It does not produce electricity). At wind speeds between 2.5 to 5 m/s, the wind turbines will start calling this "cut in wind speed". The wind speed range of about 12-15 m/s is called the "nominal or rate wind speed", with wind turbines working on their full range. At high wind speeds over 25 m/s, the wind turbine will be stopped, because wind speeds that are too high may cause damage to the mechanics of wind turbines [9]. This characteristic is shown as fig. 2

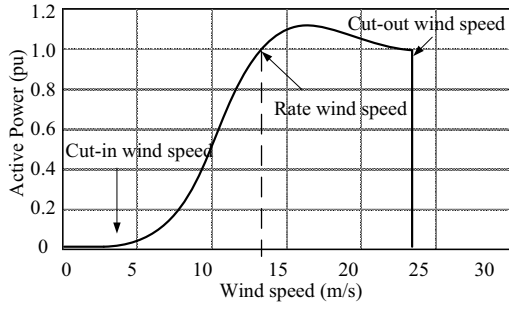

Fig. 2 The Power curve characteristic

The output power  $P_m$  is dependent on the power coefficient  $C_p$ . It is given by [10]:

$$P_m = \frac{1}{2} \rho \pi R^2 v^3 C_p(\lambda, \beta) \quad (1)$$

And the tip-speed ratio is defined as:

$$\lambda = \frac{\omega_t R}{v} \quad (2)$$

Where  $\rho$  is the specific air density ( $\text{kg/m}^3$ ),  $R$  is radius of the turbine blade (m),  $v$  is the wind speed (m/s).  $\omega_t$  is turbine speed,  $C_p$  is the coefficient of power conversion and  $\beta$  is pitch angle.

The relation of the power coefficient  $C_p(\lambda, \beta)$  is proposed:

$$C_p(\lambda, \beta) = c_1 \left( \frac{c_2}{\lambda_i} - c_3 \beta - c_4 \right) e^{-\frac{c_5}{\lambda_i}} + c_6 \lambda \quad (3)$$

With 
$$\frac{1}{\lambda_i} = \frac{1}{\lambda + 0.08\beta} - \frac{0.035}{\beta^3 + 1}$$

The coefficient  $c_1$  through  $c_6$  depends on the shape of the blade and its aerodynamic performance [11].

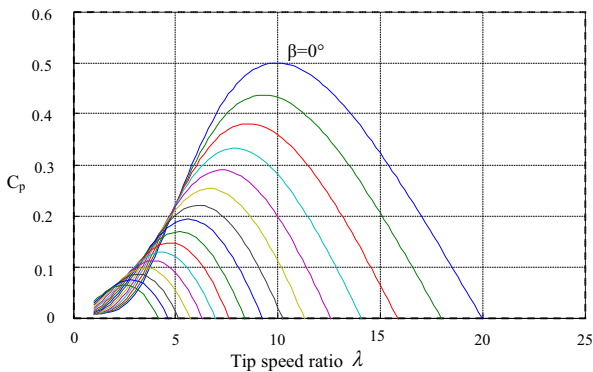

 Fig. 3 The turbine  $C_p$  characteristic

Fig. 3 shows a relationship between  $C_p$  and  $\lambda$  as the turbine  $C_p$  characteristic. There is a value of  $\lambda$  for which is maximized, maximizing thus the power for a given wind speed.

### III. DFIG SYSTEMS

The DFIG consist of a wound rotor induction generator and an AC/DC/AC IGBT-based PWM converter. All electrical variables and parameters are referred to the stator

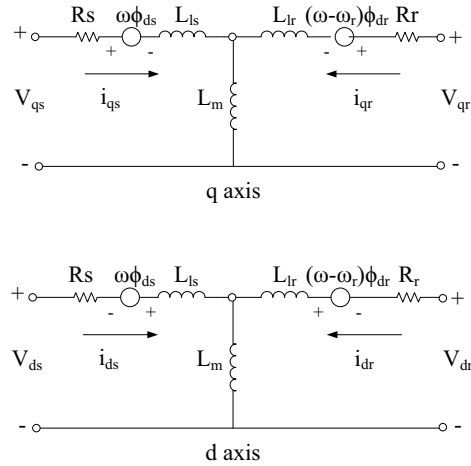

Fig. 4 The equivalent circuit of DFIG

The electrical equation of the DFIG in the equivalent circuit shows as fig. 4 and the Park's frame are written as [12]:

$$\begin{cases} v_{ds} = R_s i_{ds} + \frac{d}{dt} \phi_{ds} - \omega_s \phi_{qs} \\ v_{qs} = R_s i_{qs} + \frac{d}{dt} \phi_{qs} + \omega_s \phi_{ds} \\ v_{dr} = R_r i_{dr} + \frac{d}{dt} \phi_{dr} - (\omega_s - \omega) \phi_{qr} \\ v_{qr} = R_r i_{qr} + \frac{d}{dt} \phi_{qr} + (\omega_s - \omega) \phi_{dr} \end{cases} \quad (4)$$

The stator flux can be expressed as:

$$\begin{cases} \phi_{ds} = L_s i_{ds} + L_m i_{dr} \\ \phi_{qs} = L_s i_{qs} + L_m i_{qr} \end{cases} \quad (5)$$

The rotor flux can be expressed as:

$$\begin{cases} \phi_{dr} = L_r i_{dr} + L_m i_{ds} \\ \phi_{qr} = L_r i_{qr} + L_m i_{qs} \end{cases} \quad (6)$$

Where  $R_s$ ,  $R_r$ ,  $L_s$  and  $L_r$  are the resistances and inductance of the stator and rotor winding, respectively.  $L_m$  is the mutual inductance and  $\omega$  is the rotor speed.

$v_{ds}, v_{qs}, v_{dr}, v_{qr}, i_{ds}, i_{qs}, i_{dr}, i_{qr}, \phi_{ds}, \phi_{qs}, \phi_{dr}$  and  $\phi_{qr}$  are the direct and quadrature component of the space phasors of the stator and rotor voltage, current and flux respectively

The active and reactive powers at the stator are defined as:

$$\begin{cases} P_s = v_{ds}i_{ds} + v_{qs}i_{qs} \\ Q_s = v_{qs}i_{dr} - v_{ds}i_{qr} \end{cases} \quad (7)$$

The active and reactive powers at the rotor are defined as:

$$\begin{cases} P_r = v_{dr}i_{dr} + v_{qr}i_{qr} \\ Q_r = v_{qr}i_{dr} - v_{dr}i_{qr} \end{cases} \quad (8)$$

The electromagnetic torque is expressed as:

$$T_e = 1.5p(\phi_{ds}i_{qs} - \phi_{qs}i_{ds}) \quad (9)$$

Where  $p$  is the number of pair poles.

#### IV. CONTROL SYSTEMS

A typical structure of a PI control system [13] is shown in Fig. 5, where it can be seen that in a PI controller, the error signal  $e(t)$  is used to generate the proportional and integral actions, with the resulting signals weighted and summed to form the control signal  $u(t)$  applied to the plant model. A mathematical description of the PI controller is

$$u(t) = K_p \left[ e(t) + \frac{1}{T_i} \int_0^t e(\tau) d\tau \right] = u_p(t) + u_i(t) \quad (10)$$

Where  $K_p$  is proportion gain,  $T_i$  is integral time constant of PI controller,  $u(t)$  is the input signal to the plant model, the error signal  $e(t)$  is defined as  $e(t) = r(t) - y(t)$ , and  $r(t)$  is the reference input signal.

The PI controllers [14] are the most often type used today in industry. A control without D mode is used when:

- 1) Fast response of the system is not required.
- 2) Large disturbances and noise are present during operation of the process.
- 3) There is only one energy storage in process (capacitive or inductive).
- 4) There are large transport delays in the system.

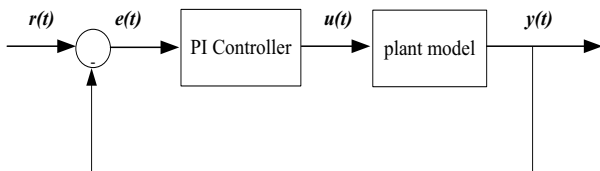

Fig. 5 A typical PI controls structure

The controller and feedback transfer functions can be equivalently written as

$$G(s) = K_p \left( 1 + \frac{1}{T_i s} \right) \quad (11)$$

The control systems based PI controller shown in Fig. 6 to Fig. 8, the scheme of control system. That controlled at the grid-side converter, the rotor-side converter and the pitch angle [15].

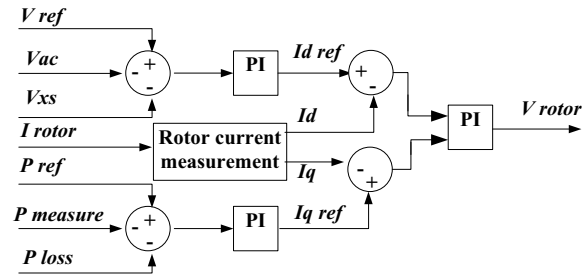

Fig. 6 The scheme of the rotor-side converter control system

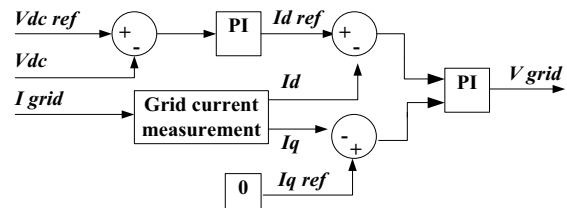

Fig. 7 The scheme of the grid-side converter control system

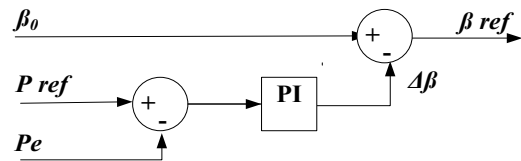

Fig. 8 The scheme of the pitch angle control system [16]

#### A. Rotor-Side Converter

The rotor side converter is used to control the wind turbine output power and the voltage or reactive power measured at the grid terminals. The power is controlled in order to follow a

pre-defined power speed characteristic (tracking characteristic) [17]. The control system is shown in Fig. 6.

We control the electromagnetic torque into the current regulator on the d-axis to compare the difference between the q-axis from var regulator (Q). Current regulator was transformed into voltage on the d-q axis, after its conversion between Cartesian to polar and polar to Cartesian. Then convert voltage control by dq0 to abc transformation to use in controlling.

### B. Grid-Side Converter

The grid side converter is used to regulate the DC bus capacitor voltage. The control system is shown in Fig. 7.

The grid-side converter control fed dc voltage regulator from difference between Vdc and Vdc reference, and transfer into the d-q axis current or the current regulator by PI controller. Then, using PI controller, transfer the regulator again into the d-q axis voltage with the electrical equation of Park's transformation. It converts not unlike the rotor-side converter into using the DFIG controlled. The PI controller is controlled at the optimum point for the DFIG systems.

### C. The pitch angle

The pitch angle is kept constant at zero degree until the speed reaches the maximum point speed of the tracking characteristic. Beyond this point the pitch angle is proportional to the speed deviation from this point speed. For electromagnetic transients in power systems, the pitch angle control is less interest. The wind speed should be selected such that the rotational speed is less than this maximum point speed. However, in this study, the two sets of average wind speed are carried out for the simulation. The wind turbine model is using Matlab/SimPowerSystems library [18]. The control system is shown in Fig. 8.

## V. SIMULATION RESULT

The case study illustrated two 1.25 MW wind farms, model consisting of 2.5 MW (two 1.25 MW wind turbine) is considered. Connected to 22 kV distribution system on a 115 kV grid through 30 km transmission line and 22 kV feeder as Fig. 9 show the simulation block systems by Simulink. This model is compared for investigating the performance by assuming the power setting corresponding to the output power either the active power (P) or reactive power (Q).

The control system uses a torque controller to maintain the generator speed at 1.2 pu. The DC voltage is regulated at constant voltage. The reactive power is kept at 0 Mvar. And optimize performance of pitch angle corresponding to wind speed into the output active power result corresponding same the input.

For the power coefficient of this model is given at  $C_p = 0.48$  and  $\beta = 2^\circ$  (the maximum pitch angle).

Initial simulation was by discrete time at  $t = 50$  microsecond. Varying the wind speed to find optimum point that correspond between the input and output power.

The result, when input fed by wind speed range between 2.8-23 m/s (cut in and cut out of the wind speed). Optimum speed is at 12.5 m/s. The output power allows the assumption, that the active power correspond power setting about 2.5 MW as shown in Fig. 10(a). At the same time, the reactive power is kept at 0 Mvar as shown in Fig. 10(b). The rotor speed maintained at about 1.2 pu. as shown in Fig.10(c). And pitch angle is monitored (the pitch angle controlled working in about 2 degree by the wind speed at 12.5 m/s is optimized), it's proper characteristic for use in wind turbines is shown in Fig. 10(d). Lastly, the active power, reactive power, rotor speed and pitch angle in range between cut in and cut out of the wind speed.

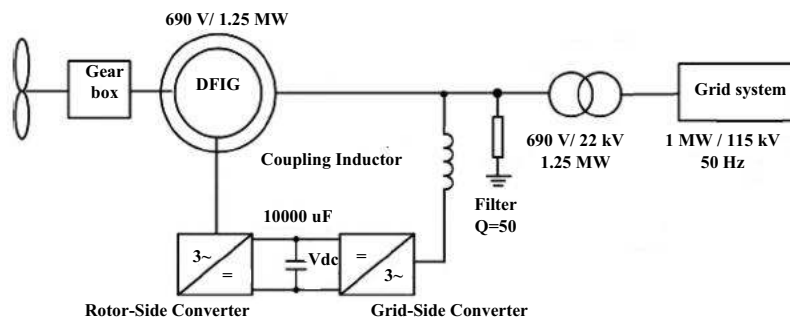
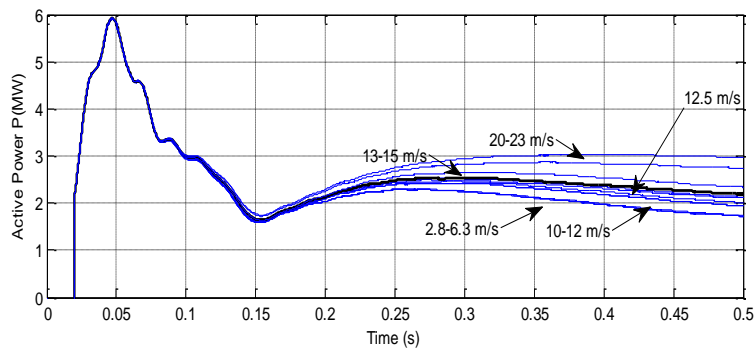
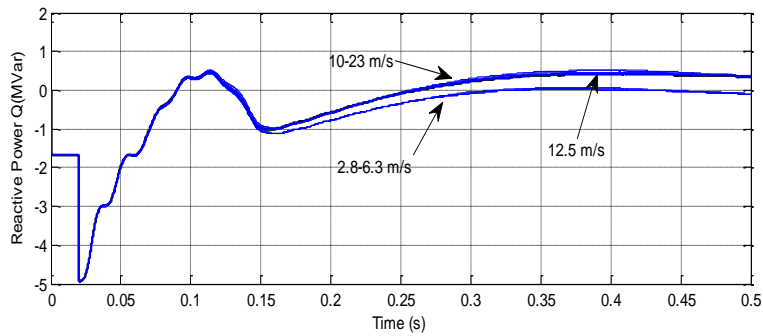

Fig. 9 The simulation block system



(a) The output active power



(b) The output reactive power

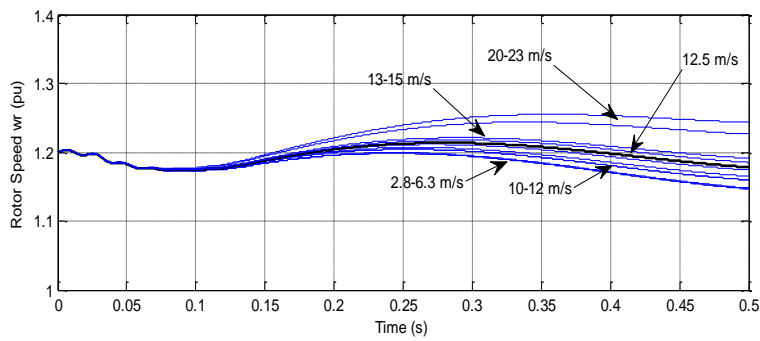

(c) The rotor speed

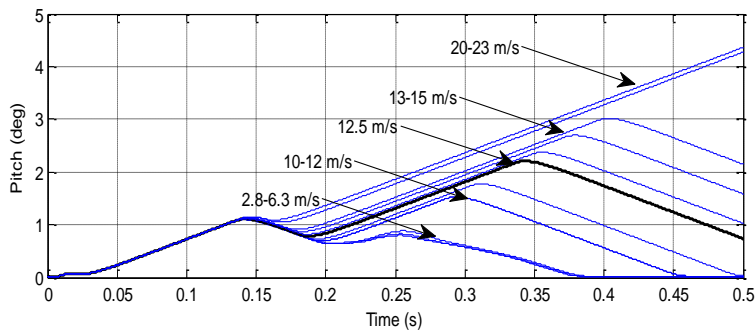

(d) The pitch angle

Fig. 10 The simulation result of the wind farm

## VI. CONCLUSION

From the simulation result, The PI controller can be performed to responding of the dynamic performance in DFIG model (in rotor-side converter, grid-side converter and the pitch angle of blade controlled), where the output power (active power) correspond the power setting, the reactive power kept at 0 Mvar, the rotor speed still controlled about 1.2 pu and the pitch angle is controlled not over 2°. Then, the wind speed is optimized performance at 12.5 m/s. It can uses the various size model for the study and monitoring such as the intelligent or advances search strategy into the future.

## ACKNOWLEDGMENT

This research was supported by Research and Development Institute Funds, Suranaree University of Technology, Nakhon Ratchasima, Thailand.

## REFERENCES

- [1] Ministry of Energy, "Wind Energy", Department of Alternative Energy Development and Efficiency (DEDE).
- [2] Akhmatov V., "Induction Generators for Wind Power", Multi-Science Publishing Company Ltd., 2005.
- [3] Anant Oonsivilai, Padej Pao-La-Or, "Application of Adaptive Tabu Search for Optimum PID Controller tuning AVR System", WSEAS TRANSACTIONS on POWER SYSTEMS, Issue 6, Volume 3, June 2008, pp 495-506.
- [4] Anant Oonsivilai, Padej Pao-La-Or, "Optimum PID controller tuning for AVR system using adaptive tabu search", World Scientific and Engineering Academy and Society (WSEAS) Stevens Point, Wisconsin, USA ©2008.
- [5] Anant Oonsivilai, Padej Pao-La-Or, "Parameter estimation of frequency response twin-screw food extrusion process using genetic algorithms", WSEAS TRANSACTIONS on SYSTEMS, Volume 7 Issue 7, July 2008.
- [6] Anant Oonsivilai, Wichai Srisuruk, Boonruang Marungsri And Thanatchai Kulworawanichpong, "Tabu Search Approach to Solve Routing Issues in Communication Networks", World Academy of Science, Engineering and Technology 53 2009, pp 1174-1177.
- [7] Gerulf K M Pedersen, Zhenyu Yang, "Multi-objective PID-controller tuning for a magnetic levitation system using NSGA-II", Proceedings of the 8th annual conference on Genetic and evolutionary computation GECCO 06 (2006), Volume: 2, Publisher: ACM Press, Pages: 1737.
- [8] <http://www.egat.co.th/re>, The wind energy of the Lumtakhong wind power plant.
- [9] Nipon Ketjoy and Achitpon Sasitharanuwat, "Wind Energy Technology", Naresuan University Journal 2004; 12(2): 57-73
- [10] Jordi Z., Josep P., Antoni A., Cyril S., Eider R. and Salvador C., "Study and experimental verification of control tuning strategies in a variable speed wind energy conversion system", Renewable Energy 36 (2011), pp 1421-1430.
- [11] Ahmed G. Abo-Khalil, Dong-Choon Lee and Seung-Pyo Ryu, "Synchronization of DFIG Output Voltage to Utility Grid in Wind Power System", KEMCO (Korea Energy Management Corporation) under project grant (2004-N-WD12-P-06-3-010-004).
- [12] D.Aouzellag, K.Ghedamsi and E.M.Berkouk, "Power Control of a Variable Speed Wind Turbine Driving an DFIG", pp 1-5.
- [13] Dingyu Xue, YangQuan Chen, and Derek P. Atherton., "Linear Feedback Control-Chapter 6. PID Controller Design", The Society for Industrial and Applied Mathematics, pp 183-235.
- [14] Prof. Zoran Vukic, PhD and Ognjen Kuljaca, "LECTURES ON PID CONTROLLERS", April, 2002
- [15] Jiabing Hu, Yikang He, Lie Xu and Barry W., "Improved Control of DFIG Systems During Network Unbalance Using PI-R Current Regulators", IEEE Transaction on Industrial electronics, Vol. 56, No. 2, February 2009, pp 439-451.
- [16] V. Ramakrishnan, S. K. Srivatsa, "Pitch Control of Wind Turbine Generator by using New Mechanism", J. Electrical Systems, Researcher, Bharath University, India 600 073
- [17] Tin Luu, Adel Nasiri, "Output Power Maximizing of a Wind Turbine by Adjusting Rotor Speed", IEEE 2008, pp 1591-1595.
- [18] MATLAB SimPowerSystems User's Guide, Version 7.9.0.529(R2009b), <http://www.mathworks.com/access/helpdesk/help/toolbox/phymod/powersys/>



**Theppitak Unchim**, was born in Ubon Ratchathani Province, Thailand, in 1985. He received his B. Eng. from Suranaree University of Technology, Thailand, in Electrical Engineering in 2007. Theppitak is currently a student in M. Eng. in School of Electrical Engineering, Suranaree University of Technology, Thailand. His areas of interest are electrical power system, stability, control technology, advance alternative, and sustainable energy.



**Anant Oonsivilai**, was born in Khon Kaen Province, Thailand, in 1963. He received his B.Eng from Khon Khan University, and M.Eng. from King Mongkut Institute of Technology North Bangkok, Thailand and PhD. From Dalhousie University, Canada, all in Electrical Engineering, in 1986, 1992 and 2000, respectively. Dr. Oonsivilai is currently an Assistant Professor in school of Electrical Engineering, Suranaree University of Technology, Thailand.