

# Fiber Optic Sensors

Bahareh Gholamzadeh, and Hooman Nabovati

**Abstract**—Fiber optic sensor technology offers the possibility of sensing different parameters like strain, temperature, pressure in harsh environment and remote locations. these kinds of sensors modulates some features of the light wave in an optical fiber such an intensity and phase or use optical fiber as a medium for transmitting the measurement information.

The advantages of fiber optic sensors in contrast to conventional electrical ones make them popular in different applications and now a day they consider as a key component in improving industrial processes, quality control systems, medical diagnostics, and preventing and controlling general process abnormalities.

This paper is an introduction to fiber optic sensor technology and some of the applications that make this branch of optic technology, which is still in its early infancy, an interesting field.

**Keywords**—Fiber optic sensors, distributed sensors, sensor application, crack sensor.

## I. INTRODUCTION

OVER the past decades many product revolutions have taken place due to the growth of the optoelectronics and fiber optic communications industries.

In the process of fiber optic developments, different researches had been done which are focused on suitable design of fibers. An offshoot of this observation was a new thoughts directed to use optical fibers in designing sensing systems, which led to the fiber based sensing devices and components.

A high volume fiber requirement in the telecommunication industry has brought down substantially the material cost of fiber sensor and the performances of the fiber improve dramatically over the years [1]. As a result, the ability of fiber optic sensors to displace traditional sensors for rotation, acceleration, electric and magnetic field measurement, temperature, pressure, acoustics, vibration, linear and angular position, strain, humidity, viscosity, chemical measurements, and a host of other sensor applications has been enhanced.

The rapidly growing interest, with fiber-based sensing owed to some attractive reasons like small size, light weight, immunity to electromagnetic interference (EMI), passive (all-dielectric) composition, high temperature performance, large bandwidth, high sensitivity, environmental ruggedness, and the ability of distributed sensing [2].

B. Gholamzadeh is with Sadjad Institute of Higher Education, Mashhad, Iran (phone: +98-915-5051041; e-mail: baharehgholamzadeh@sadjad.ac.ir ).

H. Nabovati, Department of Electrical Engineering, Sadjad Institute of Higher Education, Mashhad, Iran (e-mail: nabovati@sadjad.ac.ir ).

Fiber optics for sensing applications are used to communicate with a sensor device or use a fiber as the sensor itself to conduct continuous monitoring of physical, chemical, and biological changes in the subject or object of study.

In fiber-optic sensors, information is primarily conveyed in all optical sensors by a Change in either phase, polarization, frequency, intensity or a combination thereof. But the photo detector, being a semiconductor device, only senses intensity of light at the detector surface. So the art of sensing with polarization, phase or frequency modulation involves interferometric or grating based signal processing optical circuits [3].

The resulting signals can be then telemeter to places other than the location of the sensor by means of a fiber optic signal transmission system.

In the following sections the basic types of fiber optic sensors which are being developed are reviewed followed by a discussion of how these sensors will be applied.

## II. FIBER OPTIC SENSORS

The technology and applications of optical fibers have progressed very rapidly in recent years. Optical fiber, being a physical medium, is subjected to perturbation of one kind or the other at all times. It therefore experiences geometrical (size, shape) and optical (refractive index, mode conversion) changes to a larger or lesser extent depending upon the nature and the magnitude of the perturbation.

In communication applications one tries to minimize such effects so that signal transmission and reception is reliable. On the other hand in fiber optic sensing, the response to external influence is deliberately enhanced so that the resulting change in optical radiation can be used as a measure of the external perturbation. In communication, the signal passing through a fiber is already modulated, while in sensing, the fiber acts as a modulator. It also serves as a transducer and converts measurements data like temperature, stress, strain, rotation or electric and magnetic currents into a corresponding change in the optical radiation. Since light is characterized by amplitude (intensity), phase, frequency and polarization, any one or more of these parameters may undergo a change. The usefulness of the fiber optic sensor therefore depends upon the magnitude of this change and our ability to measure and quantify the same reliably and accurately.

The advantages of fiber optic sensors are freedom from EMI, wide bandwidth, compactness, geometric versatility and economy. In general, FOS is characterized by high sensitivity when compared to other types of sensors. It is also passive in nature due to the dielectric construction. Specially prepared

fibers can withstand high temperature and other harsh environments. In telemetry and remote sensing applications it is possible to use a segment of the fiber as a sensor gauge while a long length of the same or another fiber can convey the sensed information to a remote station. Deployment of distributed sensors covering extensive structures and geographical locations is also feasible.

### III. SENSOR CLASSIFICATION

There are a variety of fiber optic sensors. These can be classified as follows:

-- Based on the modulation and demodulation process a sensor can be called as intensity (amplitude), a phase, a frequency, or a polarization sensor. Since detection of phase or frequency in optics calls for interferometric techniques, the latter is also termed as an interferometric sensor.

-- Fiber optic sensors can also be classified on the basis of their application: physical sensors (e.g. measurement of temperature, stress, etc.); chemical sensors (e.g. measurement of pH content, gas analysis, spectroscopic studies, etc.); biomedical sensors (inserted via catheters or endoscopes which measure blood flow, glucose content and so on). Both the intensity types and the interferometric types of sensors can be considered in any of the above applications [4].

-- Extrinsic or intrinsic sensors are another classification scheme. In the former, sensing takes place in a region outside of the fiber and the fiber essentially serves as a conduit for the to-and-fro transmission of light to the sensing region efficiently and in a desired form. On the other hand, in an intrinsic sensor one or more of the physical properties of the fiber undergo a change as mentioned in above.

-- Fiber optic sensors can also be classified in response to their measurements points. The three important classes here are; point to point sensors, multiplex sensors and distributed sensors. In point to point type there is a single measurement point at the end of the fiber optic connection cable, similarly to most electrical sensors. Multiplexed sensors allow the measurement at multiple points along a single fiber line and Distributed sensors are able to sense at any point along a single fiber line, typically every meter over many kilometers of length [5].

Each of these classes of fibers in turn has many subclasses with, in some cases, sub-subclasses that consist of large number of fiber sensors. We will go through the most important types of sensors in next sections.

#### A. Intrinsic and Extrinsic Sensors

In intrinsic sensing, the properties of the fiber itself convert an environmental action into a modulation of the light beam passing through it. The modulation may be intensity, phase or polarization. Intrinsic fiber optic sensing takes place within the fiber itself. Virtually any environmental effect can be converted to an optical signal to be interpreted.

The usual case is that each environmental effect may be measured by dozens of different fiber optic sensor approaches.

The key is often to design the sensor so that only the desired environmental effect is sensed.

In contrast, in extrinsic sensing, the fiber may be used strictly as information carriers that lead up to a black box to impress information on a light beam that propagates to a remote receiver. The black box may contain mirrors, a gas or liquid cell, a cantilevered arm or dozens of other mechanisms that may generate modulate or transform a light beam [1].

#### B. Modulation Based Fiber Optic Sensor

These kinds of sensors have four main sub classes. We will discuss about each of them in this section.

##### Intensity Based Fiber Optic Sensor

In some respects the simplest type of fiber optic sensor is the extrinsic type that is based on intensity modulation. Fig. 1 shows a simple closure or vibration sensor that consists of two optical fibers held in close proximity to each other. Light is injected into one of the optical fibers; when it exits, the light expands into a cone of light whose angle depends on the difference [1].

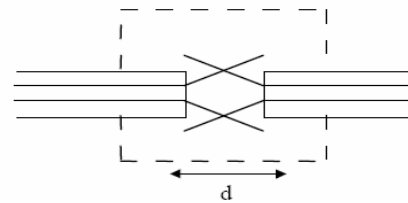

Fig. 1 Closure and vibration fiber optic sensors based on numerical aperture can be used to support door closure indicators and measure levels of vibration in machinery

For this class of sensors a normalized modulation index ( $m$ ) can be defined as:

$$m = \frac{\Delta I}{I_0 \cdot P} \quad (1)$$

Where,  $I$  = change in optical power as a result of modulation;  $I_0$  = optical power reaching the detector when there is no modulation; and  $P$  = perturbation [1].

Intensity-based fiber optic sensors have a series of limitations imposed by variable losses in the system that are not related to the environmental effect to be measured. Potential error sources include variable losses due to connectors and splices, micro bending loss, macro bending loss, and mechanical creep and misalignment of light sources and detectors. To circumvent these problems, many of the successful higher-performance, intensity-based fiber sensors employ dual wavelengths. One of the wavelengths is used to calibrate out all of the errors due to undesired intensity variations by bypassing the sensing region [5].

There are many transduction mechanisms, which can result in the light intensity change when light passes through an optical fiber, so that intensity-based fiber optic sensors can be used. These mechanisms may include: Micro bending loss, Breakage, Fiber-to-fiber coupling, Modified cladding,

Reflectance, Absorption, Attenuation, Molecular scattering, Molecular effects, Evanescent fields [6].

▪ *Intensity-type Fiber Optic Sensors Using Micro bending*

It is well known that when a fiber is bent there may be losses due to this bending. The localized bending is called micro bending. Thus, the output light intensity is proportional to the amount of micro bending. Therefore, by detecting the changes of output light intensity, the amount of micro bending can be measured so that a fiber optic sensor can be used [3].

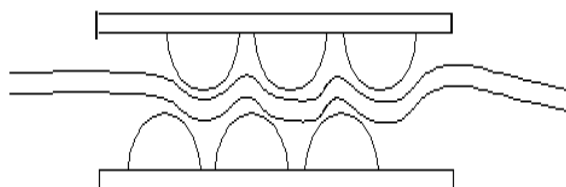

Fig. 2 Simple micro bend sensor

Besides displacement measurement, several other parameters such as strain, pressure, force and position can also be mechanically coupled to displacement of this micro ending device so that these parameters can also be measured by the same fiber sensor setup. The major advantages of micro bend sensitive fiber are that the optical fiber is low cost and when used in combination with optical time domain reflectometry techniques they may be used to cover a wide area. The principal disadvantage of using micro bend sensitive fiber is that their overall accuracy is usually rather low.

▪ *Intensity-type Fiber Optic Sensor Using Reflection*

Fig. 3 shows the basic principle of a fiber optic sensor using reflection. Light travels along the fiber from left to right, leaves the fiber end, and incidents on a movable reflector. If the reflectors move closer to the fiber, most of the light can be reflected back into the fiber so that a high light intensity signal is detected. However, when the reflector moves farther away from the exit end of the fiber, less light is coupled back into the fiber, and so a weak signal is detected. Therefore, the monotonic relationship between fiber-reflector distance, and returned light intensity can be used to measure the displacement distance. To avoid the influence of the intensity fluctuation of the light source, a suitable reference signal is usually added in this type of intensity-based fiber optic sensor.

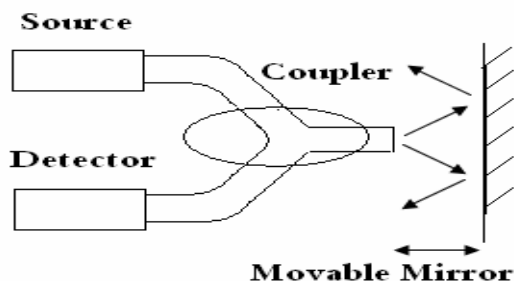

Fig. 3 Fiber Optic Sensor Using Reflection

▪ *Intensity-type Fiber Optic Sensors Using Evanescent Wave Coupling*

An evanescent wave phenomenon comes from the fact that when light propagates along a single-mode optical fiber, it is not totally confined to the core region but extends into the surrounding glass cladding region. The light wave portion in the surrounding cladding region is called an evanescent wave. This phenomenon has been used to fabricate one of the most widely used fiber optic components: a directional coupler. The coupling intensity between two fibers is a function of the distance between two fiber cores. The closer the distance, the stronger the coupling will be. Fig. 4 shows a fiber sensor based on this evanescent wave-coupling concept. Light is launched into one of the fibers, and it propagates to a region where a second core is placed in close proximity so that part of the evanescent wave of the first fiber is within the second fiber region. Thus, evanescent wave coupling happens. The coupling coefficient is directly proportional to the separation distance between the two fibers. When an environmental effect such as a pressure, an acoustic wave, or a temperature change causes the distance to change between two fibers, it results in a change in the coupling coefficient. Thus, the detected light intensity of the second fiber is also changed. Therefore, by monitoring the intensity change of the second fiber, the change in the environment can be sensed.

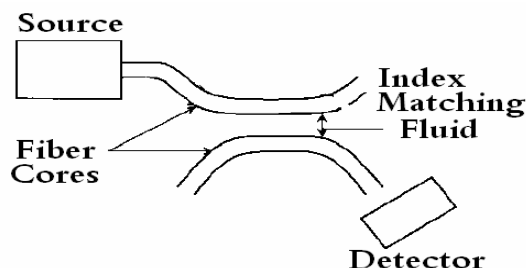

Fig. 4 Fiber Optic Sensor based on Evanescence

*Spectrally based fiber optic sensors*

Spectrally based fiber optic sensors depend on a light beam modulated in wavelength by an environmental effect. Examples of these types of fiber sensors include those based on blackbody radiation, absorption, fluorescence, etalons, and dispersive gratings.

One of the simplest of these sensor types is the blackbody sensor. A blackbody cavity is placed at the end of an optical fiber. When the cavity rises in temperature, it starts to glow and act as a light source. Detectors in combination with narrow band filters are then used to determine the profile of the blackbody curve and, in turn, the temperature.

This type of sensor has been successfully commercialized and used to measure temperature to within a few degrees centigrade under intense fields. The performance and accuracy of this sensor are better at higher temperatures and fall off at temperatures on the order of 200 centigrade because of low signal-to-noise ratios. Care must be taken to ensure that the

hottest spot is the blackbody cavity and not on the optical fiber lead itself, as this can corrupt the integrity of the signal.

#### *Polarization-based Fiber Optic Sensor*

Optical fiber is made of glass. The refractive index of the fiber can be changed from the application of stress or strain. This phenomenon is called a photo elastic effect. In addition, in many cases, the stress or strain in different directions is different, so that the induced refractive index change is also different in different directions. Thus, there is an induced phase difference between different polarization directions. In other words, under the external perturbation, such as stress or strain, the optical fiber works like a linear retarder. Therefore, by detecting the change in the output polarization state, the external perturbation can be sensed [1].

To make the fiber optic sensor practical, it is necessary to display sensitivity to the phenomena designed to measure insensitivity to changes in other environmental parameters. For the strain or stress measurement, environmental temperature is unwanted environmental parameters.

For the polarization-based fiber optic sensor, environmentally induced refractive index changes in the two polarization directions are almost the same. Thus, there is almost no induced phase difference between two polarization states. In other words,  $\Delta = 0$ . Thus, the environmental temperature fluctuation will not substantially deteriorate the sensor's performance.

#### *Phase-based Fiber Optic Sensors*

The phase of the light field can also be changed by the external perturbations so that the fiber optic sensor can also be built based on the light field's phase changes. The relationship between the phase change and the optical path change can be written as:

$$\phi(r, t) = \frac{2\pi}{\lambda} L(r, t) \quad (2)$$

Where  $\lambda$  is the light wavelength and  $L(r, t)$  represents the optical path change. Since optical wavelength is very small a small change in the optical path may result in a large change in the phase change [1].

Thus, in general, the phase-based fiber optic sensor is more sensitive than that of intensity-based fiber optic sensors. Note that, since optical detectors cannot detect the optical phase directly, the phase change is converted into an intensity change using interferometric schemes like Mach-Zehnder, Michelson, Fabry-Perot or Sagnac forms. Some types of interferometric techniques are exploited to implement phase-type fiber optic sensors.

#### ▪ *Fiber Optic Sensors Based on the Mach-Zehnder Interferometer*

Fig. 5 shows a kind of widely used fiber Mach-Zehnder interferometer based fiber optic sensor [1]. The interferometer consists of two arms: the sensing arm and the reference arm. The light coming from a coherent light source such as from a

distributed feedback (DFB) semiconductor laser is launched into the single-mode fiber. The light is then split into two beams of nominal equal intensity by a 50-50 fiber optic directional coupler. Part is sent through the sensing fiber arm, and the remainder is sent through the reference arm. After passing through the sensing and reference fiber coils, the output from these two fibers is recombined by the second fiber optic directional coupler. Thus, an interference signal between the two beams is then formed and detected by the photo detector.

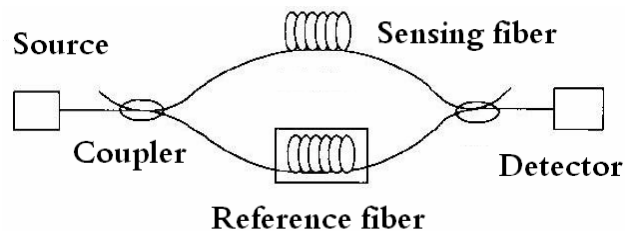

Fig. 5 Mach-Zehnder interferometer-based fiber optic sensor

To minimize the influence from slowly changing environmental factors such as temperature and to enhance the performance of the fiber sensor, in many cases the length of the reference arm is periodically modulated. This can be realized by winding the reference-arm fiber of PZT drum. A sinusoidal electric signal is added on the PZT drum so that the diameter of the drum is periodically modulated by the sinusoidal electric signal, which in turn results in the periodic change in the reference-arm length.

Note that interferometric fiber sensors are usually constructed using conventional single-mode optical fibers. Because conventional single mode fiber can support two orthogonal polarization modes and effects such as bending may occur, the fiber becomes bi-refractive. This effect can result in the change in the interference fringe visibility. Thus, the signal to-noise ratio of the sensing signal can be influenced by bi-refractive [5].

#### ▪ *Fiber Optic Sensors Based on the Michelson Interferometer*

Fig. 6 shows a kind of Michelson interferometer-based fiber optic sensor. In this case, a single directional coupler is used for both splitting and recombining the light. The light traveling from the source is split into the sensing and reference arms. After traversing the length of the arms, the light is then reflected back through the same arms by reflectors. The light is then recombined by the initial beam splitter [1].

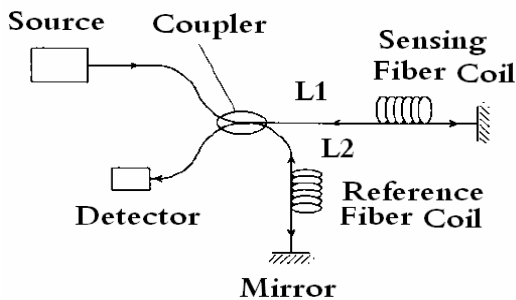

Fig. 6 Michelson interferometer-based fiber optic sensor

There are similarities and differences between the Michelson and Mach-Zehnder interferometers. In terms of similarities, the Michelson is often considered to be folded Mach-Zehnder, and vice versa. Thus, from this argument one can see that the optical loss budgets for both configurations are similar. The outputs, of course, have the same forms as the Mach-Zehnder. In term of differences, the Michelson configuration requires only one optical fiber coupler. Because the light passes through both the sensing and reference fibers twice, the optical phase shift per unit length of fiber is doubled. Thus, the Michelson can intrinsically have better sensitivity. From the practical point of view, the physical configuration of the Michelson interferometer is sometimes somewhat easier to package, although this obviously depends on the application. Another clear advantage of the Michelson is that the sensor can be interrogated with only a single fiber between the source/detector module and the sensor. However, a good-quality reflection mirror is required for the Michelson interferometer. In addition, part of the light is fed back into the optical source due to the complementary output. This can be extremely troublesome for semiconductor diode laser sources. An optical isolator is needed to minimize this adverse effect.

#### ▪ Fiber Optic Sensors Based on the Fabry-Perot Interferometer

The Fabry-Perot interferometer is a multiple-beam interferometer. Fig. 7 [1] shows a fiber optic Fabry-Perot interferometer. Due to the high reflectivity of the mirrors, in this type of interferometer the light bounces back and forth in the cavity many times, increasing the phase delay many times. The transmitted output intensity of the Fabry-Perot interferometer is given by that the higher the reflection coefficient, the sharper the interference peak will be. In other words, near the peak region, the output light intensity is very sensitive to the small change in the phase delay.

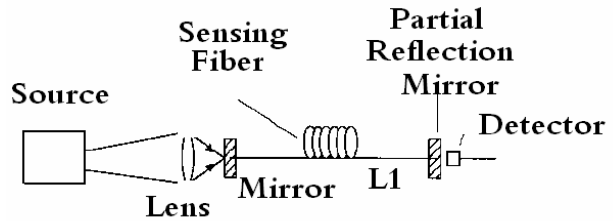

Fig. 7 Fabry-Perot interferometer-based fiber optic sensor

The larger the F number, the sharper the interference peak will be. Thus, the sensitivity of a fiber Fabry-Perot interferometer-based fiber sensor can be much higher than that of the Mach-Zehnder or Michelson interferometer [1].

#### ▪ The Sagnac Interferometer

The Sagnac interferometer has been principally used to measure rotation. It may also be employed to measure time-varying effects such as acoustics, vibration, and slowly varying phenomena such as strain.

Advantages of these sensors include extremely high sensitivity, wide area distribution, and the ability to be multiplexed in large numbers and combinations of interferometric sensors that allow the measurement of the location and amplitude of time varying events. The mass production of fiber optic gyros over the past few years offers the prospect that key interferometric components will continue to drop in price enabling cost-effective systems.

#### C. Distributed and Multiplexing Sensing

One of the most important features of fiber optic sensors is their ability of sensing many points with one fiber. These sensors use multiplexing techniques in order to use all the fiber length for sensing. We will discuss about these techniques in below sections

##### Multiplexing Sensing

In some applications there may be a need for multisensory systems. Such a system can be realized in a number of ways. One way is to arrange a set of discrete (point) sensors in a network or array configuration, with individual sensor outputs multiplexed. The most commonly employed techniques are time, frequency, wavelength, coherence, polarization, and spatial multiplexing.

##### ▪ TDM

Time division multiplexing employs a pulsed light source, launching light into an optical fiber and analyzing the time delay to discriminate between sensors. This technique is commonly employed to support distributed sensors where measurements of strain, temperature, or other parameters are collected.

Fig. 8 [1] illustrates a time division multiplexed system that uses micro bend-sensitive areas on pipe joints. As the pipe joints are stressed, micro bending loss increases and the time delay associated with these losses allows the location of faulty

joints. The entire length of the fiber can be made micro bend-sensitive and Rayleigh scattering loss used to support a distributed sensor that will predominantly measure strain.

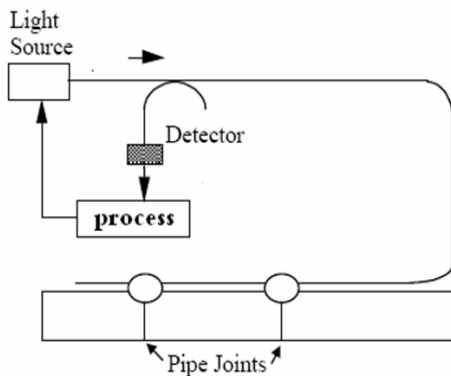

Fig. 8 Time division multiplexing methods can be used in combination with microbend-sensitive optical fiber to locate the position of stress along a pipeline

▪ *WDM*

Wavelength division multiplexing is one of the best methods of multiplexing as it uses optical power very efficiently. It also has the advantage of being easily integrated into other multiplexing systems, allowing the possibility of large numbers of sensors supported in a single fiber line.

Fig. 9 illustrates a system where a broadband light source, such as a light-emitting diode, is coupled into a series of fiber sensors that reflect signals over wavelength bands that are subsets of the light source spectrum. A dispersive element, such as grating or prism, is used to separate the signals from the sensors onto separate detectors.

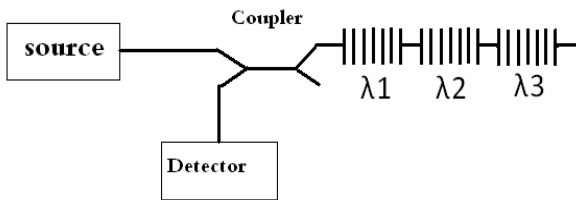

Fig. 9 Wavelength division multiplexing is often very energy-efficient. A series of fiber sensors is multiplexed by being arranged to reflect in a particular spectral band that is split via a dispersive element onto separate detectors

▪ *Polarization Multiplexing*

One of the least commonly used techniques is polarization multiplexing. In this case the idea is to launch light with particular polarization states and extract each state. A possible application is shown in Fig. 10 [1], where light is launched with two orthogonal polarization modes; preserving fiber and evanescent sensors have been set up along each of the axes. A polarizing beam splitter is used to separate the two signals. There is recent interest in using polarization-preserving fiber in combination with time domain techniques to form polarization-based distributed fiber sensors. This has the

potential to offer multiple sensing parameters along a single fiber line [1].

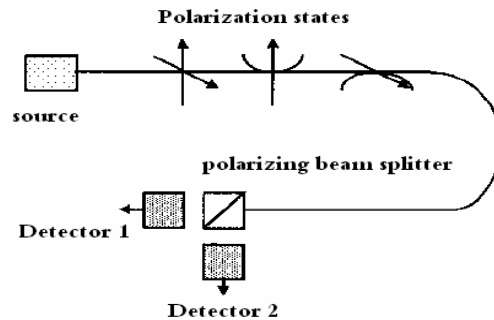

Fig. 10 Polarization multiplexing is used to support two fiber sensors that access the cross-polarization states of polarization-preserving optical fiber

▪ *SDM*

Finally, it is possible to use spatial techniques to generate large sensor arrays using relatively few input and output optical fibers. Fig. 11 [1] shows a 2 by 2 array of sensors where two light sources are amplitude-modulated at different frequencies. Two sensors are driven at one frequency and two more at the second. The signals from the sensors are put onto two output fibers, each carrying a sensor signal from two sensors at different frequencies. This sort of multiplexing is easily extended to m input fibers and n output fibers to form m by n arrays of sensors [1].

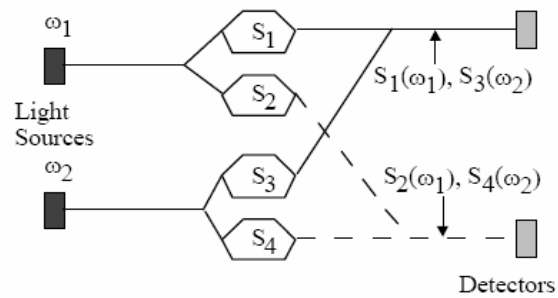

Fig. 11 Spatial multiplexing of four fiber optic sensors may be accomplished by operating two light sources with different carrier frequencies and cross-coupling the sensor outputs onto two output fibers

*Distributed Sensing*

Alternatively, it is more interesting to exploit the inherent ability of the fiber sensors to create unique forms of distributed sensing.

A distributed sensor is, conventionally, a device with a linear measurement basis, which is sensitive to measurand at any of its points. Optical fiber distributed sensors consist of a single optical fiber sensitive over all its length. A single distributed fiber optic sensor could therefore replace thousands of discrete sensors. The low fiber attenuation allows a monitoring over extremely long distances (up to 25 kilometers), which represent an impressive number of

measuring points. This makes distributed sensing technique a very attractive solution when the monitoring of a large number of locations is required [5].

Basically, there are two types of distributed fiber optic sensors: intrinsic distributed fiber optic sensors and quasi-distributed fiber optic sensors. For the intrinsic distributed fiber optic sensors, a single measurand can be monitored continuously over the path of the fiber. The most typical intrinsic distributed fiber optic sensor is optical time-domain reflectometry (OTDR). However, in some cases truly distributed sensing is difficult to realize, and so the quasi-distributed fiber optic sensors are used. In this case, the measurand is not monitored continuously along the fiber path, but at a finite number of locations by multiplexing point fiber optic sensors. In particular, in many cases, quasi-distributed fiber optic sensors can be simply realized by integrating many point fiber optic sensors.

Both intrinsic and quasi-distributed fiber optic sensors are based on monitoring the change of optical signals propagating along the fiber. In general, a monochromatic optical field  $E(r, t)$ , can be written as:

$$E(r, t) = A(r, t)e^{j(\omega t + \phi(r, t))} \quad (3)$$

Where  $A(r, t)$  is the amplitude of the complex light field,  $\omega$  is the angular frequency of the monochromatic light field, and  $\phi(r, t)$  is the phase of the complex field. This equation shows us the key parameters, which are used to describe the light fields, including:

1. The polarization—direction of the electric field
2. The amplitude or intensity
3. The frequency or wavelength of the light field
4. The phase

All these parameters may be subject to change due to external perturbations. Thus, by detecting these parameters and their changes, the external perturbations can be detected or sensed.

#### ▪ *Intrinsic Distributed Fiber Optic Sensors*

Intrinsic distributed fiber optic sensors are particularly effective for use in applications where monitoring a single measurand is required at a large number of points or continuously over the path of the fiber. These sensors can be classified as below:

--Optical Time-Domain Reflectometry Based on Rayleigh scattering

--Optical Time-Domain Reflectometry Based on Raman Scattering

--Optical Time-Domain Reflectometry Based on Brillouin Scattering

-- Optical Frequency-Domain Reflectometry

In Optical Time-Domain Reflectometry Based on Rayleigh scattering, When light is launched into an optical fiber, loss occurs due to Rayleigh scattering that arises as a result of random, microscopic (less than wavelength) variations in the index of refraction of the fiber core. A fraction of the light

scattered in a counter propagation direction (i.e., 180° relative to the incident direction) is recaptured by the fiber aperture and returned toward the source. When a narrow optical pulse is launched in the fiber, by monitoring the variation of the Rayleigh backscattered signal intensity, one can determine the spatial variations in the fiber scattering coefficient, or attenuation. Since the scattering coefficient of a particular location reflects the local fiber status, by analyzing the reflection coefficient, one can sense the localized external perturbation or fiber status. Thus, distributed sensing can be realized.

Raman scattering types, involves the inelastic scattering of photons. The molecular vibrations of glass fiber (induced by incident light pulse) cause incident light to be scattered. The

The major difficulty of Raman-OTDR is the low Raman scattering coefficient, which is about three orders of magnitude weaker than that of the Rayleigh. Thus, high input power is needed to implement Raman-OTDR [6].

Brillouin scattering occurs from acoustic vibrations stimulated in the optical fiber when an optical pulse is launched into an optical fiber. The acoustic vibrations cause a counter propagating wave that drains energy away from forward-moving input pulse. This counter propagating scattering wave is called a Brillouin scattering wave. To satisfy the requirement of energy conservation, there is a frequency shift between the original light pulse frequency and the Brillouin scattering wave, which, in general, is in the order of tens of GHz. Since the frequency shift of a Brillouin gain spectrum is sensitive to the temperature and strain, it becomes a very useful effect to build fiber optic sensors. In particular, the frequency shift depends on the magnitude of the longitudinal strain, which comes from the fact that, under different longitudinal strain conditions, the acoustic wave frequency induced by the photon is different. Thus, the longitudinal strain distribution can be measured based on the Brillouin scattering effect [5].

In order to obtain a high spatial resolution, a very narrow light pulse is required, which results in a proportionally lower level of the backscattering signal and the increased receiver bandwidth requirement for detecting these pulses. Thus, a larger increase in the noise level is expected so that only strong reflections can be detected in noise. To increase the spatial resolution without sacrificing the backscattering signal intensity, optical frequency-domain reflectometry (OFDR) was developed [1].

In the OFDR, coherent detection is needed. Since conventional single mode fiber cannot hold the polarization state of the light propagating in the fiber, polarization-insensitive detection is expected.

#### ▪ *Quasi-distributed Fiber Optic Sensors*

When truly distributed sensing is difficult to realize, the quasi-distributed fiber optic sensor techniques are used. In this technique, the measurand is not monitored continuously along the fiber path, but at a finite number of locations.

This is accomplished either by sensitizing the fiber locally to a particular field of interest or by using extrinsic-type

sensing elements. The use of quasi-distributed fiber optic sensors means more measurands can be sensed.

Theoretically speaking, by cascading a set of point sensors together one can achieve quasi-distributed sensing. For example, when a series of reflectors is fabricated in the fiber, a quasi-distributed fiber optic sensor based on discrete reflectors can be built. The OTDR technique can then be used to analyze the relative position of these reflectors. The changes of these reflection signals can be used to sense the changes in these discrete locations [1].

Although quasi-distributed fiber optic sensors may be based on a variety of principles such as Fresnel reflection and cascaded interferometers, fiber Bragg grating-based quasi-distributed fiber optic sensors have unique features including high sensitivity, a high multiplexing capability (such as using wavelength division multiplexing), and cost-effectiveness.

The concept of fiber Bragg grating can be traced back to the discovery of the photosensitivity of germanium-doped silica fiber [6]. It was found that when an argon ion laser was launched into the core of the fiber, under prolonged exposure, an increase in the fiber attenuation was observed. In addition almost all of the incident radiation back reflected out of the fiber. Spectral measurements confirmed that the increase in reflectivity was the result of a permanent refractive Index grating's being photo induced in the fiber. This photo induced permanent grating in the germanium-doped silica fiber is called fiber Bragg grating. During that time, it was also found that the magnitude of the photo induced refractive index depended on the square of the writing power at the argon ion wavelength (488 nm). This suggested a two-photo process as the possible mechanism of refractive index change.

Almost a decade later, in 1989, Meltz showed that a strong index of refraction change occurred when a germanium-doped fiber was exposed to direct, single-photon, UV light close to 5 eV. This coincides with the absorption peak of a Germanium-related defect at a wavelength range of 240–250 nm. Irradiating the side of the optical fiber with a periodic pattern derived from the intersection of two coherent 244-nm beams in an interferometer resulted in a modulation of the core index of refraction, inducing a periodic grating. Changing the angle between the intersecting beams alters the spacing between the interference maxima; this sets the periodicity of the gratings, thus making reflectance possible at any wavelength. This makes the fiber Bragg grating have practical applications because the original approach was limited to the argon ion writing wavelength (488 nm), with very small wavelength changes induced by straining the fiber. Reliable mass-produced gratings can also be realized by using the phase masks [1].

The principle of UV-induced refractive index in germanium-doped silica fiber may be explained in the following: under the UV-light illumination, there are oxygen vacancies located at substitution Ge sites, which results in ionized defect band bleaching, liberating an electron and creating a hole trap. Thus, the refractive index for the regions under UV exposure is different from the unexposed regions.

One of the most important properties of fiber Bragg grating is wavelength-selective reflection. Assume that a broadband light is coupled into a fiber with fiber Bragg grating inside. The light whose wavelength matches the Bragg condition will be reflected back. The light whose wavelength does not match the Bragg condition will be transmitted through the fiber. The Bragg condition can be written as follows:

$$\lambda_B = 2n_{eff}\Lambda \quad (4)$$

Where  $\lambda_B$  is the Bragg grating wavelength that will be reflected back from the Bragg grating,  $n_{eff}$  is the effective refractive index of the fiber core at wavelength  $\lambda_B$ , and  $\Lambda$  is Bragg Period.

The major motivation of applying fiber Bragg grating to fiber sensor is the capability of integrating a large number of fiber Bragg gratings in a single fiber so that quasi-distributed fiber sensing can be realized in a compact, cost-effective way [5]. Currently, with the rapid advent of optical communication networks, more than 100 wavelength channels can be put in a single fiber by using the wavelength division multiplexing technique [6]. Thus, if we assign one central wavelength for each grating, more than 100 sensors can be integrated into a single fiber. Furthermore, by applying time division to each wavelength channel, there would be a increase in the number of sensors that can be integrated. Therefore, a compact, cost-effective distributed fiber sensor can be built.

#### IV. FIBER OPTIC SENSORS APPLICATION

Fiber optic sensors have been subject to considerable research for the past 30 years or so since they were first demonstrated about 40 years ago [2].

These new sensing technologies have formed an entirely new generation of sensors offering many important measurement opportunities and great potential for diverse applications. The most highlighted application fields of FOS are in large composite and concrete structures, the electrical power industry, Medicine, Chemical sensing, and The gas and oil industry.

##### *A. Applications to Large Composite and Concrete Structures*

Fiber optic sensors have several distinguishing advantages in comparison with traditional electrical sensors like potential capability of surviving in harsh environments, A much less intrusive size for embedding into composites without introducing any significant perturbation to the characteristics of the structure, Greater resistance to corrosion when used in open structures, such as bridges and dams. These features have made them very attractive for quality control during construction, health monitoring after building, impact monitoring of large composite or concrete structures. Some applications of these sensors in bridges, dams, mines, and aircraft have been demonstrated [1].



### *Bridges*

One of the first monitoring demonstrations for large structures was a highway bridge using carbon fiber-based composite pre stressing tendons for replacement of steel-based tendons to solve the serious corrosion problem. Because composite materials are not well proven in their substitution for steel in concrete structures, there is considerable interest in monitoring the strain and deformation or deflection, temperature, or environmental degradation within such types of composite structures using an integrated fiber optic sensing system. FBG sensors could be suitable for achieving such a goal [6].

### *Dams*

Dams are probably the biggest structures in civil engineering hence it is vital to monitor their mechanical properties during and after construction in order to ensure the construction quality, longevity, and safety of the dam.

Fiber optic sensors are ideal for health monitoring applications of dams due to their excellent ability to realize long-range measurement. Truly distributed FOS are particularly attractive as they normally have tens of km measurement range with meter spatial resolution.

One of the most important parameter for monitoring in dams is temperature. This monitoring is of prime importance as the density and micro cracks are directly related to the maximum temperature the concrete experiences during the setting chemical process. A distributed temperature sensor using Brillouin scattering can be used to monitor this feature [6].

### *Mines*

Measurement of load and displacement changes in underground excavations of mines and tunnels is vital for safety monitoring. Multiplexed FBG sensor systems could replace the traditional electrical sensors, such as strain gauges and load cells, which cannot be operated in a simple multiplexed fashion and in a very hazardous environment with strong electro-magnetic interference generated by excavating machinery. An FBG sensor system can be designed for long-term static displacement measurement in the ultimate roof of the mining excavations and in the hanging wall of the ore body's mineshaft [1].

### *Aircraft*

Advanced composite materials are now routinely used for manufacturing engineering structures such as aerospace structures (e.g., parts of airplane wings). Compared with metallic materials, advanced composite materials can have higher fatigue resistance, lighter weight, higher strength-to-weight ratio, the capability of obtaining complex shapes, and no corrosion. Hence, the use of composite materials with embedded FBG systems can lead to a reduction in weight, inspection intervals, and maintenance cost of aircraft and, consequently, to an improvement in performance. However, there is a major challenge in realizing real-time health and

usage monitoring in service with an onboard sensor system. A distributed FBG sensor system could be ideally suitable for such an application. Because FBG sensors are sensitive to both strain and temperature, it is essential to measure strain and temperature simultaneously in order to correct the thermally induced strain for static strain measurement. A simple and effective method often used is to employ an unstrained temperature reference FBG [1].

### *B. Application in the Electric Power Industry*

Electric current measurement using FOS in 1977 is probably the earliest application of these sensors in the electric power industry. After more than two decades of development, fiber-optic current sensors entered the market. These current sensors based on the Faraday Effect have found important applications in fault detection and metering.

Like other implementations of fiber optic sensors, the FBG is ideal for use in the electrical power industry due to its immunity to electromagnetic interference. Loading of power transmission lines, winding temperature of electrical power transformers have been measured with the FBG sensor [1].

### *Load Monitoring of Power Transmission Lines*

An excessive mechanical load on electrical power transmission lines, which may be caused by heavy snow for example, may lead to a serious accident. In particular, for those lines located in for example, mountainous areas, there is no easy access for inspection. Therefore, an online measurement system is needed to monitor the changing load on the power line. A multiplexed FBG system can be used here. The load change is simply converted into strain via a metal plate attached to the line and onto which the FBG is bonded. Obviously many more sensors are required for such an application.

WDM may no longer be able to cope with the significant increase in sensor number due to the limited bandwidth of the light source; however, TDM could be used to improve the multiplexing capacity considerably. As the distance between adjacent FBGs is large, high-speed modulation and demodulation would not be required. Overall, this is an excellent example of applying FBG sensors for long-distance remote monitoring in harsh environments [1].

### *Winding Temperature Measurement*

Knowledge of the local temperature distribution present in high-voltage, high-power equipment, such as generators and transformers, is essential in understanding their operation and in verifying new or modified products.

Defective or degraded equipment can be detected by continuously monitoring the variations in the winding temperature, which reflects the performance of the cooling system. FBG sensors are the best choice for this application [1].

### *C. Application in Medicine*

The majority of commercial sensors widely used in medicine are electrically active and hence not appropriate for

use in a number of medical applications. Fiber optic sensors can overcome these problems as they are virtually dielectric. A range of miniature fiber optic sensors based on intensity modulation has been successfully commercialized in recent years. Generally speaking, these sensors are all point sensors that can only provide readings over a small volume in the human body. Although passive multiplexing of these point sensors is possible, it is difficult to achieve in practice due to limitations on the probe size. By using the unique multiplexing property of the FBG sensor is possible to realize quasi-distributed sensor systems with a single fiber link.

#### *Blood Monitoring*

The FBG sensor can also be used for the measurement of the heart's efficiency based on the flow-directed thermo dilution catheter method in which doctors inject patients with a cold solution to measure their heart's blood output. A flow-directed thermo dilution catheter is inserted into the right atrium of the heart, allowing the solution to be injected directly into the heart for measurement of the, temperature of the blood in the pulmonary artery. By combining temperature readings with pulse rate, doctors can determine how much blood the heart pumps. Such a type of catheter with an FBG sensor has been used for replacement of a conventional catheter. To simulate the change of blood flow due to the size change of the blood vessel when the pump rate is kept constant, a clamp is used to squeeze the tubing [1].

#### *Detection of Cataract*

By simply monitoring the backscattered light intensity from the lens of the eye, the onset of alpha-crystallite aggregation can be detected by autocorrelation measurements. The onset is delineated by a bimodal distribution of particle size in the backscattered radiation.

#### *D. Application in the Oil and Gas Industry*

Fiber optic sensors could be ideal for applications in the oil and gas industry due to their inherent advantages, such as being intrinsically safe, immune to EMI, workable at high temperature, capable of multiplexing, and minimally invasive.

Of these advantages, the multiplexed or distributed sensing feature is particularly attractive for applications, where monitoring of a parameter or parameters at many spatial locations through the well is essentially necessary.

#### *Monitoring Pipe Line*

FBG sensors can be used in pipeline in order to monitor the temperature in the pipe or the pressure on the joints.

Because refractive index of these fibers is sensitive to pressure and temperature ones can monitor all the length of the pipe by one fiber by using multiplexing methods.

### V. CRACK SENSORS

The existing condition of many important concrete structures can be accessed through the detection and monitoring of cracking. For example, in concrete bridge decks, crack openings beyond 0.15 to 0.2 mm will allow

excessive penetration of water and chloride ions, leading to the corrosion of steel reinforcements.

Conventionally, crack detection and monitoring for bridges have been carried out by visual inspection. The procedure is time consuming, expensive, and yet unreliable. Recently, various researchers have developed fiber optics-based crack sensors for concrete structures. Existing optical crack sensors are, however, very limited in their applications. For example, sensing based on fiber can distinguish between the presence and absence of cracking but cannot provide information on gradual structural degradation. Point sensors, can detect and monitor the opening of a crack only if the cracking occurs in a small region that is known a priori. The sensor employed in this study was based on the measurement of the intensity loss due to deformation. These sensors were calibrated and were embedded in a fiber reinforced concrete specimen.

Researchers at the Massachusetts Institute of Technology and Brown University developed a sensor for the reliable detection and monitoring of cracks in concrete structure. The sensor is based on a distributed optical fiber micro bending sensor [6].

An optical fiber is embedded in the concrete element in a zigzag shape like Fig. 12 [6].

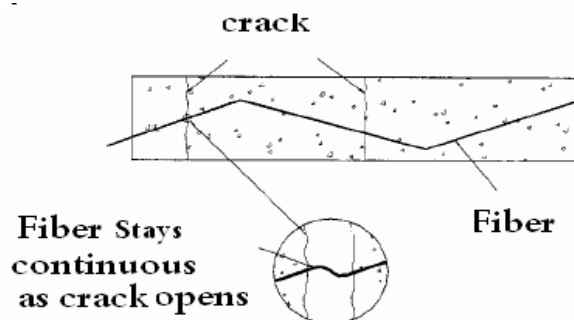

Fig. 12 Principle of operation of the zigzag sensor

Using OTDR equipment, the light intensity distribution along the fiber is measured. Before the formation of cracks, the backscattered signal along the fiber should follow a relatively smooth curve - the upper line in Fig. 12 - In the straight portions of the fiber, the small loss is due to absorption and scattering. In the curved portion where the fiber turns in direction macro bending loss may occur depending on the radius of curvature [6].

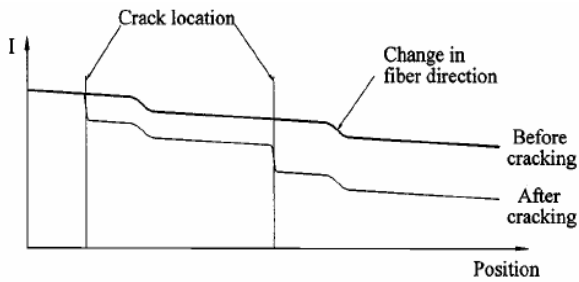

Fig. 13 Intensity along the fiber, measured by means of the optical time-domain reflectometry

When a crack opens in the structure, as shown in Fig. 12 a fiber intersecting the crack at an angle other than  $90^\circ$  has to bend to stay continuous. This perturbation in the fiber is very abrupt, and thus can be considered as micro bending. This micro bending results in a sharp drop in the optical signal and the lower line in Fig. 13 [6] will be generated. This intensity loss is detected and located by means of the OTDR equipment. Also, from the magnitude of the drop, the crack opening can be obtained if a calibration relation is available.

The proposed technique does not require prior knowledge of the crack locations, which is a significant advancement over existing crack monitoring techniques. Moreover, several cracks can be detected, located, and monitored with a single fiber. For the sensor to work, however, crack directions need to be known. An ideal application of the sensor is in the monitoring of flexural cracks in bridges, which may appear at arbitrary locations along the deck.

## VI. CONCLUSION

The field of optical fiber sensors has advanced substantially in the past ten years following the developments made within the supporting component technology driven by the telecommunications industry. Reflecting the relative maturity of the technology, research activity within universities and industrial centers has shifted from demonstrating physical concepts to producing test instruments that can then be engineered into preproduction prototypes. In making this significant shift in emphasis, optical fiber researchers have had to more closely address issues associated with the application of optical fibers in harsh, practical environments.

Fiber optic sensors will undoubtedly have a role to play within a structural monitoring context where much of the research and development effort has been focused. However, there is clearly a significant scope for these sensors elsewhere; for example, within the electricity supply industry, where optical measurement techniques offer sensitivity and performance improvements while reducing costs by minimizing the requirements for insulation.

## REFERENCES

- [1] F.Yu,S.Yin, *Fiber optic sensors*. Marcel-Dekker, 2002.
- [2] D.A .Krohn, "Fiber optic sensors-Fundamental and applications," Instrument Society of America.
- [3] E.Udd Et Al, *Fiber optic smart structures*. John Wiley& Sons INC, New

York.

- [4] DAKIN Dakin and B.Culshaw, *Optical fiber sensors-Principles and components*. Vol.I, Artech House, Boston.
- [5] C.M.Davis, E.F.Carome, M.H.Weik, S.Ezekiel, R.E.Einzig, *Fiber optic sensors technology handbook*. Optical Technologies- A Division of Dynamic System INC.
- [6] Joan R.Casas, Paulo J.S.Cruz, M.ASCE, "Fiber optic sensors for bridge monitoring," *Journal of bridge engineering*.