

Joint Design of MIMO Relay Networks Based on MMSE Criterion

Seungwon Choi, Seungri Jin, Ayoung Heo, Jung-Hyun Park and Dong-Jo Park

Abstract—This paper deals with wireless relay communication systems in which multiple sources transmit information to the destination node by the help of multiple relays. We consider a signal forwarding technique based on the minimum mean-square error (MMSE) approach with multiple antennas for each relay. A source-relay-destination joint design strategy is proposed with power constraints at the destination and the source nodes. Simulation results confirm that the proposed joint design method improves the average MSE performance compared with that of conventional MMSE relaying schemes.

Keywords—minimum mean square error (MMSE), multiple relay, MIMO.

I. INTRODUCTION

A wireless network comprises a number of nodes connected by wireless channels. The use of relay transmission is an important technique to widen network coverage and to increase the capacity of the source and destination communication systems [1], [2]. A great deal of research on wireless relay networks has been performed, but most of it considers systems which consist of a single source-destination with a single antenna and multiple relays with a single antenna. Several studies have examined multiple source-destination pair systems, in which all nodes have only one antenna [3], [4]. In [3] and [4], relaying schemes based on zero-forcing (ZF) and the minimum mean square error (MMSE) were proposed.

Sources, relays, and destinations can be equipped with multiple antennas to enhance the overall system performance. For systems with one source-destination pair and one relay node in the network, several schemes have been developed based on the MMSE criterion [5]–[7]. The authors in [5] proposed a relay-destination joint optimization scheme, and the authors in [6], [7] researched source-relay-destination joint design schemes. When there exist multiple relays, the source-relay-destination joint optimization is known to be hard to solve. To obtain an MMSE-based relaying solution for multiple relays, a conventional MMSE filter is simply applied only at the relay side in [8], and in [9], a receiver-relay joint design which minimizes the MSE is proposed, with the power constraint at the destination node rather than at the relay output to simplify the optimization problem.

In this paper, we consider a relay network in which multiple source nodes, multiple relay nodes, and a single destination node exist. Each node in the network is equipped with multiple

The authors are affiliated with Department of Electrical Engineering, Korea Advanced Institute of Science and Technology (KAIST), 335 Gwahak-ro, Yuseong-gu, Daejeon 305-701, Republic of Korea. (e-mail: charchar@kaist.ac.kr; seungri@kaist.ac.kr; hay507@kaist.ac.kr; junghyun-park@kaist.ac.kr; djpark@kaist.ac.kr).

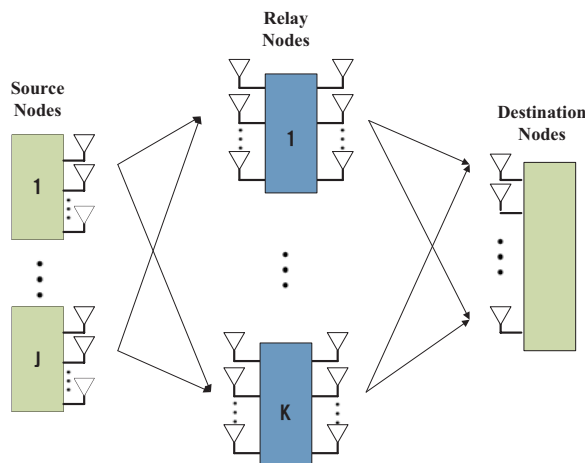

Fig. 1. Description of MIMO relay networks.

antennas, and we provide a sub-optimal joint design scheme based on the MMSE criterion. We used two power constraints: 1) a power constraint at the destination, and 2) a power constraint at the source. Simulation results show that the proposed joint design method improves the average MSE performance compared with that of conventional MMSE relaying schemes.

The organization of this paper is described as follows. Section II shows a system model that considers wireless relay networks. Section III presents the proposed relay schemes. Section IV outlines the simulation results. Finally, Section V draws a conclusion.

Notations: Boldface capital letters and lowercase letters denote matrices and vectors, respectively. The superscripts $(\cdot)^T$, $(\cdot)^H$, $(\cdot)^{-1}$, $(\cdot)^\dagger$, and $E(\cdot)$ denote transpose, Hermitian, inversion, pseudo-inversion, and expectation operations, respectively. $\mathbf{A} \succeq \mathbf{0}$ denotes that a matrix \mathbf{A} is positive semidefinite and $\text{tr}(\cdot)$ denotes the trace. \mathbf{I}_N means the identity matrix of size $N \times N$ and $\text{blkdiag}(\mathbf{A}_1, \dots, \mathbf{A}_N)$ denotes a block diagonal matrix which consists of $\mathbf{A}_1, \dots, \mathbf{A}_N$. A random vector whose entries are taken from a complex normal distribution with a mean \mathbf{m} and a covariance matrix \mathbf{R} is denoted by $\mathbf{x} \sim \mathcal{CN}(\mathbf{m}, \mathbf{R})$.

II. SYSTEM MODEL

Consider the wireless network shown in Fig. 1, where J source nodes transmit symbols to the destination node through K relay nodes. Each source node has L antennas, the destination node is equipped with M antennas, and each relay node has N antennas.

A simple two-phase (two-hop) protocol is used to transmit data from multiple source nodes to the destination node. The first phase (hop) is the broadcasting phase, during which the source nodes broadcast a signal vector towards the relay nodes. The second phase (hop) is the relaying phase, during which each relay node transmits its signal vector $\mathbf{r}_k \in \mathcal{C}^{N \times 1}$, $k = 1, 2, \dots, K$ to the destination node. Note that there are no direct links between the source nodes and the destination node.

We denote by $\mathbf{G} = [\mathbf{G}_1 \ \dots \ \mathbf{G}_J]$ the $NK \times JL$ channel matrix between the source and the relay nodes, while $\mathbf{H} = [\mathbf{H}_1 \ \dots \ \mathbf{H}_K]$ is the $M \times NK$ channel matrix between the relay nodes and the destination node where \mathbf{G}_i is the $NK \times L$ channel matrix between the i -th source and the relays and \mathbf{H}_n is the $M \times K$ channel matrix between the n -th relay and the destination. By singular value decomposition (SVD), \mathbf{G} and \mathbf{H} are decomposed as $\mathbf{G} = \mathbf{U}_G \mathbf{\Lambda}_G \mathbf{V}_G^H$ and $\mathbf{H} = \mathbf{U}_H \mathbf{\Lambda}_H \mathbf{V}_H^H$, respectively. $\mathbf{\Lambda}_G$ and $\mathbf{\Lambda}_H$ are matrices with non-negative entries along the main diagonal and are arranged in decreasing order. Each element of the channel matrices follows $\mathcal{CN}(0, 1)$. The i -th source node transmits $N_{s,i}$ streams through L antennas, and the received signal at the relay nodes can then be represented as

$$\mathbf{r} = \mathbf{G}\mathbf{T}\mathbf{s} + \mathbf{n}_r, \quad (1)$$

where \mathbf{T} is a $JL \times N_S$ ($= \sum_{i=1}^J N_{S,i}$) source precoder, which has a block diagonal structure, \mathbf{s} is an $N_S \times 1$ symbol vector, and \mathbf{n}_r is an additive white Gaussian noise (AWGN) with a covariance matrix $\sigma_r^2 \mathbf{I}_{NK}$. In the second phase of transmission, each relay node rebroadcasts a transformed signal vector by an $N \times N$ matrix \mathbf{F}_i for $i = 1, \dots, K$, and the received signal at the destination node is

$$\mathbf{y} = \mathbf{H}\mathbf{F}\mathbf{G}\mathbf{T}\mathbf{s} + \mathbf{H}\mathbf{F}\mathbf{n}_r + \mathbf{n}_d, \quad (2)$$

where $\mathbf{F} = \text{blkdiag}(\mathbf{F}_1, \dots, \mathbf{F}_K)$ is an $NK \times NK$ block diagonal matrix and \mathbf{n}_d is an AWGN with a covariance matrix $\sigma_d^2 \mathbf{I}_M$. An $N_S \times M$ receiving matrix \mathbf{W} is used to detect the transmitted data streams:

$$\hat{\mathbf{s}} = \mathbf{W}\mathbf{y}. \quad (3)$$

When channel state information (CSI) is available at all nodes, \mathbf{W} , \mathbf{T} and \mathbf{F} can be jointly determined to improve the performance of the MIMO relay network. In this paper, we adopt the trace of the MSE matrix as our performance metric to jointly design \mathbf{W} , \mathbf{T} and \mathbf{F} .

III. JOINT SOURCE-RELAY-DESTINATION DESIGN

In this section, we jointly design \mathbf{W} , \mathbf{T} and \mathbf{F} to minimize the MSE. Let us define the following:

$$\begin{aligned} \tilde{\mathbf{F}} &\triangleq \mathbf{H}\mathbf{F} \\ &= \begin{bmatrix} \mathbf{H}_1 \mathbf{F}_1 (\triangleq \tilde{\mathbf{F}}_1) & \dots & \mathbf{H}_K \mathbf{F}_K (\triangleq \tilde{\mathbf{F}}_K) \end{bmatrix}. \end{aligned} \quad (4)$$

The MSE matrix, which represents the covariance matrix of the symbol detection errors of data streams, is defined as

$$\mathcal{M} \triangleq E \left((\mathbf{s} - \hat{\mathbf{s}})(\mathbf{s} - \hat{\mathbf{s}})^H \right). \quad (5)$$

By using (2), (3) and (4), the MSE matrix \mathcal{M} can be represented as a function of \mathbf{W} , \mathbf{T} and $\tilde{\mathbf{F}}$:

$$\begin{aligned} \mathcal{M}(\mathbf{W}, \tilde{\mathbf{F}}, \mathbf{T}) &= \mathbf{W}\mathbf{R}_{nn}\mathbf{W}^H \\ &\quad + \left[\mathbf{W}\tilde{\mathbf{F}}\mathbf{G}\mathbf{T} - \mathbf{I}_{N_S} \right] \left[\mathbf{W}\tilde{\mathbf{F}}\mathbf{G}\mathbf{T} - \mathbf{I}_{N_S} \right]^H, \end{aligned} \quad (6)$$

where

$$\mathbf{R}_{nn} = \sigma_r^2 \tilde{\mathbf{F}}\tilde{\mathbf{F}}^H + \sigma_d^2 \mathbf{I}_M. \quad (7)$$

The optimization problem for minimizing the MSE under the power constraints is written as

$$\min_{\mathbf{W}, \mathbf{F}, \mathbf{T}} (\text{tr}(\mathcal{M}(\mathbf{W}, \mathbf{F}, \mathbf{T}))) \quad (8)$$

subject to

$$\begin{aligned} \text{tr}(\mathbf{H}\mathbf{F}(\mathbf{G}\mathbf{T}\mathbf{T}^H\mathbf{G}^H + \sigma_r^2\mathbf{I})\mathbf{F}^H\mathbf{H}^H) &\leq P_r \text{tr}(\mathbf{H}\mathbf{H}^H) \\ \text{and } \text{tr}(\mathbf{T}\mathbf{T}^H) &\leq P_s, \end{aligned} \quad (9)$$

where P_s is the total power of the sources and P_r is the total power of the relays. In (9), the first constraint, which is a power constraint at the destination, is obtained as follows (for more details, see [9]):

$$\begin{aligned} \text{tr}(\mathbf{H}\mathbf{F}(\mathbf{G}\mathbf{T}\mathbf{T}^H\mathbf{G}^H + \sigma_r^2\mathbf{I}_{NK})\mathbf{F}^H\mathbf{H}^H) \\ \leq \text{tr}(\mathbf{F}(\mathbf{G}\mathbf{T}\mathbf{T}^H\mathbf{G}^H + \sigma_r^2\mathbf{I}_{NK})\mathbf{F}^H) \cdot \text{tr}(\mathbf{H}\mathbf{H}^H) \\ = P_r \cdot (\mathbf{H}\mathbf{H}^H). \end{aligned} \quad (10)$$

For given \mathbf{T} and \mathbf{F} , the MMSE equalizer \mathbf{W} is easily expressed as

$$\begin{aligned} \mathbf{W} &= \mathbf{T}^H \mathbf{G}^H \tilde{\mathbf{F}}^H (\tilde{\mathbf{F}}\mathbf{G}\mathbf{T}\mathbf{T}^H\mathbf{G}^H\tilde{\mathbf{F}}^H + \mathbf{R}_{nn})^{-1} \\ &= (\mathbf{T}^H \mathbf{G}^H \tilde{\mathbf{F}}^H \mathbf{R}_{nn}^{-1} \tilde{\mathbf{F}}\mathbf{G}\mathbf{T} + \mathbf{I}_{N_S})^{-1} \mathbf{T}^H \mathbf{G}^H \tilde{\mathbf{F}}^H \mathbf{R}_{nn}^{-1}. \end{aligned} \quad (11)$$

From (6) and (11), we obtain the following result:

$$\mathcal{M}(\tilde{\mathbf{F}}, \mathbf{T}) = (\mathbf{T}^H \mathbf{G}^H \tilde{\mathbf{F}}^H \mathbf{R}_{nn}^{-1} \tilde{\mathbf{F}}\mathbf{G}\mathbf{T} + \mathbf{I}_{N_S})^{-1}. \quad (12)$$

Now, we let $\tilde{\mathbf{F}}$ as $\tilde{\mathbf{F}} = \mathbf{Q}_t \mathbf{Q}_r$ where \mathbf{Q}_r is an $N_S \times NK$ relay receiver matrix and \mathbf{Q}_t is an $M \times N_S$ relay transmitter matrix. Then, \mathbf{Q}_r can be represented as follows (see [7]):

$$\mathbf{Q}_r = (\mathbf{T}^H \mathbf{G}^H \mathbf{G}\mathbf{T} + \sigma_r^2 \mathbf{I}_{N_S})^{-1} \mathbf{T}^H \mathbf{G}^H. \quad (13)$$

By using (13) and the matrix inversion lemma, $\mathcal{M}(\mathbf{Q}_t, \mathbf{T})$ can be decomposed as

$$\begin{aligned} \mathcal{M}(\mathbf{Q}_t, \mathbf{T}) &= \mathbf{I}_{N_S} - \mathbf{T}^H \mathbf{G}^H \mathbf{Q}_r^H \mathbf{Q}_t^H \mathbf{Z}^{-1} \mathbf{Q}_t \mathbf{Q}_r \mathbf{G}\mathbf{T} \\ &= \mathbf{I}_{N_S} - \frac{1}{\sigma_d^2} \mathbf{J}^H \mathbf{Q}_t^H \mathbf{Q}_t \mathbf{J} + \frac{1}{\sigma_d^2} \mathbf{J}^H \mathbf{Q}_t^H \mathbf{Q}_t \mathbf{Z}^{-1} \mathbf{Q}_t^H \mathbf{Q}_t \mathbf{J} \\ &= \mathbf{I}_{N_S} - \frac{1}{\sigma_d^2} \mathbf{J}^H \mathbf{Q}_t^H \mathbf{Q}_t \mathbf{J} \\ &\quad + \frac{1}{\sigma_d^2} \mathbf{J}^H \mathbf{Q}_t^H \mathbf{Q}_t \mathbf{Z}^{-1} (\mathbf{Z} - \mathbf{R}_{Q_r}^{-1}) \mathbf{J} \\ &= \mathbf{I}_{N_S} - \frac{1}{\sigma_d^2} \mathbf{J}^H \mathbf{Q}_t^H \mathbf{Q}_t \mathbf{Z}^{-1} \mathbf{R}_{Q_r}^{-1} \mathbf{J} \\ &= \mathbf{I}_{N_S} - \mathbf{J}^H (\mathbf{Z} - \mathbf{R}_{Q_r}^{-1}) \mathbf{Z}^{-1} \mathbf{R}_{Q_r}^{-1} \mathbf{J} \\ &= \mathbf{I}_{N_S} - \mathbf{J}^H \mathbf{R}_{Q_r}^{-1} \mathbf{J} + \mathbf{J}^H \mathbf{R}_{Q_r}^{-1} \mathbf{Z}^{-1} \mathbf{R}_{Q_r}^{-1} \mathbf{J} \end{aligned} \quad (14)$$

where $\mathbf{J} = \mathbf{Q}_r \mathbf{G} \mathbf{T}$, $\mathbf{Z} = \mathbf{R}_{\mathbf{Q}_r}^{-1} + \frac{1}{\sigma_d^2} \mathbf{Q}_t^H \mathbf{Q}_t$, and $\mathbf{R}_{\mathbf{Q}_r}$ is the covariance matrix of \mathbf{Q}_r ($\mathbf{G} \mathbf{T} \mathbf{s} + \mathbf{n}_r$). In (14), $\mathbf{R}_{\mathbf{Q}_r}^{-1} \mathbf{J}$ is an identity matrix, so that we finally obtain the following result:

$$\mathcal{M}(\mathbf{Q}_t, \mathbf{T}) = \sigma_r^2 (\mathbf{T}^H \mathbf{G}^H \mathbf{G} \mathbf{T} + \sigma_r^2 \mathbf{I}_{N_s})^{-1} + \sigma_d^2 (\mathbf{Q}_t^H \mathbf{Q}_t + \sigma_d^2 \mathbf{R}_{\mathbf{Q}_r}^{-1})^{-1}. \quad (15)$$

If it is assumed that $1/\sigma_r^2 \gg 1$, then $\mathbf{R}_{\mathbf{Q}_r}$ rapidly goes to the identity matrix. In this case \mathbf{T} and \mathbf{Q}_t can be designed independently. Thus, the optimization problem in (8) can be divided into two optimization problems as follows:

$$\min_{\mathbf{T}} \left(tr \left(\sigma_r^2 (\mathbf{T}^H \mathbf{G}^H \mathbf{G} \mathbf{T} + \sigma_r^2 \mathbf{I}_{N_s})^{-1} \right) \right) \quad (16)$$

s.t. $tr(\mathbf{T} \mathbf{T}^H) \leq P_s$

and $\min_{\mathbf{Q}_t} \left(tr \left(\sigma_d^2 (\mathbf{Q}_t^H \mathbf{Q}_t + \sigma_d^2 \mathbf{R}_{\mathbf{Q}_r}^{-1})^{-1} \right) \right) \quad (17)$

s.t. $tr(\mathbf{Q}_t \mathbf{R}_{\mathbf{Q}_r} \mathbf{Q}_t^H) \leq P_r \cdot tr(\mathbf{H} \mathbf{H}^H)$.

A. Single-Source Multiple-Relay Case

The cost functions of the optimization problems (16) and (17) are minimized when $\sigma_r^2 (\mathbf{T}^H \mathbf{G}^H \mathbf{G} \mathbf{T} + \sigma_r^2 \mathbf{I}_{N_s})^{-1}$ and $\sigma_d^2 (\mathbf{Q}_t^H \mathbf{Q}_t + \sigma_d^2 \mathbf{R}_{\mathbf{Q}_r}^{-1})^{-1}$ are diagonal matrices because the trace function is a Schur-concave function [7]. Therefore, it can be obtained that $\mathbf{Q}_t = \mathbf{U}_Q \mathbf{\Lambda}_Q$ and $\mathbf{T} = \mathbf{V}_{\mathbf{G}, N_s} \mathbf{\Lambda}_T$ where \mathbf{U}_Q is an $M \times N_s$ matrix constructed by any N_s orthonormal vectors, $\mathbf{V}_{\mathbf{G}, N_s}$ is the first N_s columns of \mathbf{V}_G , $\mathbf{\Lambda}_Q = \text{diag}(\lambda_{Q,1}, \dots, \lambda_{Q,N_s})$, and $\mathbf{\Lambda}_T = \text{diag}(\lambda_{T,1}, \dots, \lambda_{T,N_s})$. Then, the solution of (16) is given as

$$\lambda_{T,i}^2 = \left(\sqrt{\frac{\sigma_r^2}{\gamma_T \lambda_{G,i}^2} - \frac{\sigma_r^2}{\lambda_{G,i}^2}} \right)^+ \quad (18)$$

where $(x)^+ \triangleq \max(x, 0)$ and γ_T is the Lagrangian multiplier of the optimization problem (16). If $\mathbf{T} = \mathbf{V}_{\mathbf{G}, N_s} \mathbf{\Lambda}_T$, then $\mathbf{R}_{\mathbf{Q}_r}$ has a diagonal structure. Therefore, the solution of (17) is easily obtained as follows:

$$\lambda_{Q,i}^2 = \left(\sqrt{\frac{\sigma_d^2 (\lambda_{G,i}^2 \lambda_{T,i}^2 + \sigma_r^2)}{\gamma_Q \lambda_{G,i}^2 \lambda_{T,i}^2} - \frac{\sigma_d^2 (\lambda_{G,i}^2 \lambda_{T,i}^2 + \sigma_r^2)}{\lambda_{G,i}^2 \lambda_{T,i}^2}} \right)^+ \quad (19)$$

where γ_Q is the Lagrangian multiplier of the optimization problem (17). Finally, we obtain $\mathbf{F}_i = \mathbf{H}_i^\dagger \tilde{\mathbf{F}}_i$ for $i = 1, \dots, K$ where \mathbf{H}_i^\dagger is pseudo-inversion of the channel between the i -th relay and the destination nodes.

B. Multiple-Source Multiple-Relay Case

When there exist multiple sources, \mathbf{T} is a block diagonal matrix $\mathbf{T} = \text{blkdiag}(\mathbf{T}_1, \dots, \mathbf{T}_J)$. In general, if \mathbf{T} has a block diagonal structure, $\sigma_r^2 (\mathbf{T}^H \mathbf{G}^H \mathbf{G} \mathbf{T} + \sigma_r^2 \mathbf{I}_{N_s})^{-1}$ cannot

be a diagonal matrix. By the matrix inversion lemma, the trace of the MSE matrix in (16) is rewritten as

$$\begin{aligned} & tr \left(\sigma_r^2 (\mathbf{T}^H \mathbf{G}^H \mathbf{G} \mathbf{T} + \sigma_r^2 \mathbf{I}_{N_s})^{-1} \right) \\ &= tr(\mathbf{I}_{N_s}) - tr \left((\sigma_r^2 \mathbf{I}_{NK} + \mathbf{G} \mathbf{T} \mathbf{T}^H \mathbf{G}^H)^{-1} \mathbf{G} \mathbf{T} \mathbf{T}^H \mathbf{G}^H \right) \\ &= tr(\mathbf{I}_{N_s}) - tr \left((\sigma_r^2 \mathbf{I}_{NK} + \mathbf{G} \tilde{\mathbf{T}} \mathbf{G}^H)^{-1} \mathbf{G} \tilde{\mathbf{T}} \mathbf{G}^H \right) \\ &= tr(\mathbf{I}_{N_s}) - \sum_{i=1}^{NK} \frac{\mu_i}{\sigma_r^2 + \mu_i} = tr(\mathbf{I}_{N_s}) - NK + \sum_{i=1}^{NK} \frac{\sigma_r^2}{\sigma_r^2 + \mu_i} \\ &= N_s - NK + \sigma_r^2 tr \left(\left[\sum_{i=1}^J \mathbf{G}_i \tilde{\mathbf{T}}_i \mathbf{G}_i^H + \sigma_r^2 \mathbf{I}_{NK} \right]^{-1} \right) \end{aligned} \quad (20)$$

where $\tilde{\mathbf{T}} = \text{blkdiag}(\tilde{\mathbf{T}}_1, \dots, \tilde{\mathbf{T}}_J)$, $\tilde{\mathbf{T}}_i = \mathbf{T}_i \mathbf{T}_i^H$, and μ_i for $i = 1, \dots, NK$ is the eigenvalues of $\mathbf{G} \tilde{\mathbf{T}} \mathbf{G}^H$. Therefore, the optimization problem in (16) is equivalent to minimizing the last term in (20), i.e.,

$$\begin{aligned} & \min_{\tilde{\mathbf{T}}_i} \left(tr \left(\left[\sum_{i=1}^J \mathbf{G}_i \tilde{\mathbf{T}}_i \mathbf{G}_i^H + \sigma_r^2 \mathbf{I}_{NK} \right]^{-1} \right) \right) \quad (21) \\ & \text{s.t. } tr \left(\sum_{i=1}^J tr(\tilde{\mathbf{T}}_i) \right) \leq P_s, \text{ and } \tilde{\mathbf{T}}_i \succeq 0. \end{aligned}$$

The above problem is convex and can be solved by MATLAB optimization tools, such as a primal-dual interior point solver. Notice that problem (21) is equivalent to minimizing the MSE for multiuser MIMO systems [10]. For a given \mathbf{T} , it can be assumed that the optimal \mathbf{Q}_t is a form of $\mathbf{Q}_t = \mathbf{U}_Q \mathbf{\Lambda}_Q \mathbf{V}_R^H$ where $\mathbf{R}_{\mathbf{Q}_r} = \mathbf{V}_R \mathbf{\Lambda}_R \mathbf{V}_R^H$. Then,

$$\begin{aligned} & \min_{\mathbf{Q}_t} \left(tr \left(\sigma_d^2 (\mathbf{Q}_t^H \mathbf{Q}_t + \sigma_d^2 \mathbf{R}_{\mathbf{Q}_r}^{-1})^{-1} \right) \right) \\ &= \min_{\mathbf{\Lambda}_Q} \left(tr \left(\sigma_d^2 (\mathbf{\Lambda}_Q^2 + \sigma_d^2 \mathbf{\Lambda}_R^{-1})^{-1} \right) \right) \end{aligned} \quad (22)$$

and

$$\lambda_{Q,i}^2 = \left(\sqrt{\frac{\sigma_d^2}{\gamma_Q \lambda_{R,i}} - \frac{\sigma_d^2}{\lambda_{R,i}}} \right)^+. \quad (23)$$

Finally, we obtain $\mathbf{F}_i = \mathbf{H}_i^\dagger \tilde{\mathbf{F}}_i$ for $i = 1, \dots, K$.

IV. SIMULATION RESULTS

In this section, we investigate the MSE performance and the achievable sum rate of the proposed scheme. A network was formed by a single destination, multiple sources, and multiple relay nodes. All nodes are equipped with multiple antennas. We assumed that $\sigma_r^2 = \sigma_d^2 = \sigma^2$ and $SNR = \frac{P_r}{\sigma^2}$.

In Fig. 2, we show the MSE performance of the proposed and other scheme as SNR , when $JL = 4$, $N = 4$, $M = 4$ and $N_s = 2$. The notations, 'woSD' and 'woS' denote the MMSE-based relaying schemes proposed in [8] and [9], respectively. To minimize the MSE, relay nodes and a destination node are jointly optimized at 'woS' and only the relay precoder is considered at 'woSD.' In 'woS' and 'woSD,' it can be thought that $J = 1$ and $L = 4$, since they do not considered precoder at the source node. The proposed scheme improves the MSE performance compared with those of conventional schemes.

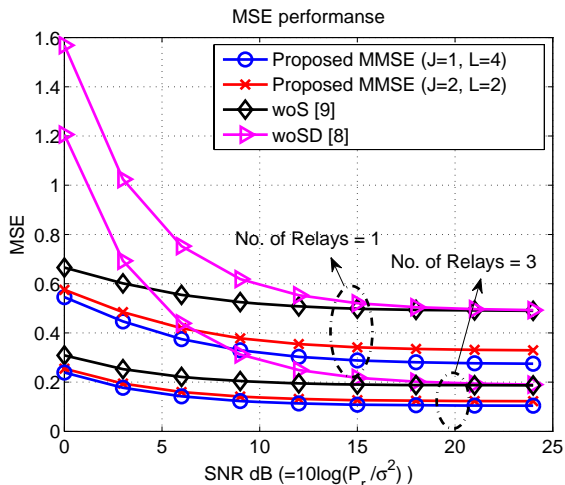

Fig. 2. MSE performance vs SNR when $P_s/\sigma^2 = 3$ dB.

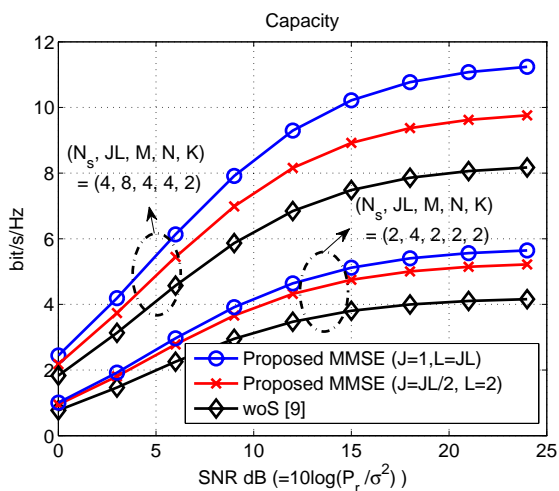

Fig. 3. Capacity performance vs SNR when $P_s/\sigma^2 = 3$ dB.

Note that the performance of the proposed scheme is still better than other schemes even in the low SNR region, though the proposed source and relay precoders are derived in the high SNR regime.

The capacity achieved by the proposed scheme versus SNR is shown in Fig. 3. When there are multiple sources, the performance is degraded in comparison with a single source case, since source nodes can share only channel information.

V. CONCLUSION

We have addressed an MMSE-based relaying scheme for a relay network, which consists of single destination, multiple sources, and multiple relays with multiple antennas. With power constraints at the receiver and at the source, we have proposed a sub-optimal source-relay-destination joint design scheme. In order to confirm the performance of the proposed method, we investigated the MSE performance and the achievable sum rate. Although the proposed source and relay

precoders are derived under the assumption $1/\sigma_r^2 \gg 1$, the proposed scheme shows better MSE performance than that of the conventional MMSE relaying schemes, even in the low SNR region.

ACKNOWLEDGMENT

This work was partially supported by Defense Acquisition Program Administration and Agency for Defense Development under the contract. (UD110006MD)

REFERENCES

- [1] J. N. Laneman, D. Tse, and G. Wornell, "Cooperative diversity in wireless networks: efficient protocols and outage behavior," *IEEE Transactions on Information Theory*, vol. 50, no. 12, pp. 3062-3080, Dec. 2004.
- [2] G. Kramer, M. Gastpar, and P. Gupta, "Cooperative strategies and capacity theorems for relay networks," *IEEE Transactions on Information Theory*, vol. 51, no. 9, pp. 3037-3063, Sep. 2005.
- [3] A. Wittneben and I. Hammerstrom, "Multiuser zero forcing relaying with noisy channel state information," *IEEE Wireless Communications and Networking Conference*, vol. 2, pp. 1018-1023, Mar. 2005.
- [4] S. Berger and A. Wittneben, "Cooperative distributed multiuser MMSE relaying in wireless Ad-Hoc networks," *Conference Record of the Thirty-Ninth Asilomar Conference on Signals, Systems and Computers*, pp. 1072-1076, Oct. 2005.
- [5] W. Guan and H. Luo, "Joint MMSE transceiver design in nonregenerative MIMO relay systems," *IEEE Communications Letters*, vol. 12, pp. 517-519, Jul. 2008.
- [6] R. Mo and Y. H. Chew, "MMSE-based joint source and relay precoding design for amplify-and-forward MIMO relay networks," *IEEE Transactions on Wireless Communications*, vol. 8, no. 9, pp. 4668-4676, Sep. 2009.
- [7] C. Song, K. J. Lee, and I. Lee, "MMSE based transceiver designs in closed-loop non-regenerative MIMO relaying systems," *IEEE Transactions on Wireless Communications*, vol. 9, no. 7, pp. 2310-2410, Jul. 2010.
- [8] O. Oyman and A. J. Paulraj, "Design and analysis of linear distributed MIMO relaying algorithms," *IEE Proceedings on Communications*, vol. 153, no. 4, pp. 565-572, Aug. 2006.
- [9] A. S. Behbahani, R. Merched, and A. M. Eltawil, "Optimization of a MIMO Relay Network," *IEEE Transactions on Signal Processing*, vol. 56, no. 10, pp. 5062-5073, Oct. 2008.
- [10] S. Serbetli and A. Yener, "Transceiver optimization for multiuser MIMO systems," *IEEE Transactions on Signal Processing*, vol. 52, no. 1, pp. 214-226, Jan. 2004.