

# Investigation of Recirculation Effects on the Formation of Vapor Bubbles in Centrifugal Pump Blades

Mohammad Taghi Shervani Tabar, Seyyed Hojjat Majidi, Zahra Poursharifi

**Abstract**—Cavitation in pumps is known as the formation of vapor bubbles due to pressure drop and collapsing these bubbles. In some conditions, it has been observed that the formation of bubbles occurs at the pressure side of centrifugal pump blades. In this study, the formation of bubbles at the pressure side of blades has been investigated. Water is used in this study as the fluid and performance curves were depicted for different flow rates in an approximately constant speed. The results show that when a centrifugal pump works in low flow rates, a secondary flow namely recirculation starts to begin. In this condition, separation of flow increases which causes vortex formation and local pressure drop and eventually the formation of vapor bubbles starts.

**Keywords**—Cavitation, Centrifugal pump, Recirculation, Vapor bubble.

## I. INTRODUCTION

AT recent decades cavitation and the effects of it on hydraulic design of pumps has been one of the technical–scientific goals of managers, engineers and scientists. For investigating this phenomenon, there have been various studies on centrifugal pumps. As an important result of these studies, nowadays pumps can operate safely against cavitation even at high velocities. Several investigators have stressed the fact that pump failures associated to cavitation depends on a large number of design and operational parameters such as type of pump, design type, and the use of suction specific speed [1].

The term ‘cavitation’ comes from the Latin word *cavus*, which means a hollow space or a cavity. In the context of centrifugal pumps, the term cavitation implies a dynamic process of formation of bubbles inside the liquid, their growth and subsequent collapse as the liquid flows through the pump. Vaporization of the liquid can occur in centrifugal pumps. When the local static pressure reduces below that of the vapor pressure of the liquid at the pumping temperature, the reduction of static pressure in the internal suction system

occurs mainly due to the rise in the velocity at the impeller eye (Fig. 1). Unless there is no change in the operating conditions, new bubbles continue to form and old bubbles grow in size. The bubbles then get carried in the liquid as it flows from the impeller eye to the impeller exit tip along the vane trailing edge. Due to impeller rotating action, the bubbles attain very high velocity and eventually reach the regions of high pressure within the impeller where they start collapsing. As the vapor bubbles move along the impeller vanes, the pressure around the bubbles begins to increase until a point is reached where the pressure on the outside of the bubble is greater than the pressure inside the bubble and then the bubble collapses [2]. The process is not an explosion but rather an implosion. Hundreds of bubbles collapse at approximately the same point on each impeller vane. Bubbles collapse non-symmetrically such that a hammering action occurs. The highly localized hammering effect can pit the pump impeller. After the bubble collapses, a shock wave emanates outward from the point of collapse. This kind of cavitation is known as NPSHA insufficiency.

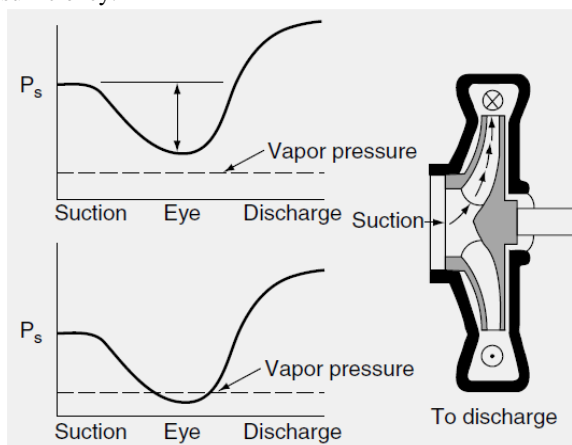

Fig. 1 Suction pressure falling below vapor pressure causes bubble formation [3].

Cavitation damage to a centrifugal pump may range from minor pitting to catastrophic failure and depends on the pumped fluid characteristics, energy levels, and duration of cavitation. Most of the damage usually occurs within the impeller; specifically, to the leading face of the non-pressure

Mohammad Taghi Shervani Tabar is with the Department of Mechanical Engineering, Tabriz University, Tabriz, Iran (email :msherv@tabrizu.ac.ir).

Seyyed Hojjat Majidi is with the Department of Mechanical Engineering, Iran University of Science and Technology, Tehran, Iran (email : h\_majidi@Mecheng.iust.ac.ir).

Zahra Poursharifi is with the Department of Mechanical Engineering, Tabriz University, Tabriz, Iran (email: z.poursharifi@gmail.com).

side of the vanes. The net effect observed on the impeller vane will be a pockmarked, rough surface and severe thinning of the vanes from metal erosion [3]. It should be mentioned that cavitation might happen even at stationary components of a hydraulic machine or at rotating parts (such as the impeller of a centrifugal pump). Additives in the liquid which increase vapor pressure, as well as corrosive properties of the liquid, can increase cavitation damage. Different materials show different resistance to the cavitation. In general, there is no material that can be completely resistant to this phenomenon. Rigid plastics and composites are normally the least cavitation resistant materials. Cast iron and brass will experience the most damage of commonly used metals, while stainless steel, titanium, nickel, aluminum, and bronze will have much less damage, under the same cavitation conditions [4].

Another type of cavitation seen in pumps is due to a phenomenon called as recirculation. One of the complex problems associated with operation of pumps is that of recirculation. Recirculation is defined as flow reversal either at the inlet or at the outlet tips of the impeller vanes. This reversal causes a vortex that attaches itself to the pressure side of the vane. If there is enough energy available and the velocities are high enough, damage will occur. There are two types which may occur together or separately: suction recirculation and discharge recirculation.

Suction recirculation is a condition created by operating the pump at low flows, and it frequently dictates the low-flow limit of stable operation of the pump in relation to the percentage of BEP. In the petroleum industry, it is usually referred to as the 'minimum flow for stable operating condition', and is frequently required to be identified by the pump supplier for consideration in the pump evaluation process. This kind of recirculation is the reversal of flow at the impeller eye. A portion of the flow is directed out of the eye at the eye diameter, as shown in Fig. 2 and travels upstream with a rotational velocity approaching the peripheral velocity of the diameter. A rotating annulus of liquid is produced upstream from the impeller inlet and through the core of this annulus passes an axial flow corresponding to the output capacity of the pump. The high shear rate between the rotating annulus and the axial flow through the core produces vortices that form and collapse, producing noise and cavitation in the suction of the pump.

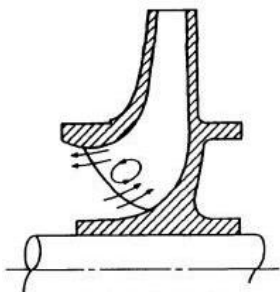

Fig. 2 Suction recirculation [5].

In the other side, discharge recirculation is another condition precipitated by low-flow operation that takes effect at a lower flow than suction recirculation, and also displays similar symptoms. Discharge recirculation occurs when high pressure flow streams re-enter the impeller on the low pressure side of the impeller vane. This is caused by the pump operating back on its curve or with an inlet restriction [6]. The reverse flow within the impeller passage shears across the outgoing flow, sets up vortices along the pressure wall of the impeller, and causes cavitation along the pressure wall and shrouds adjacent to the impeller outlet (Fig. 3):

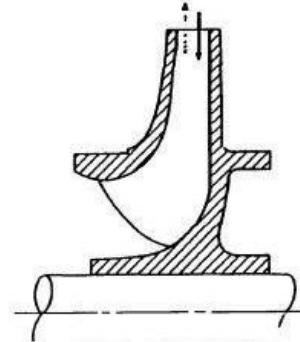

Fig. 3 Discharge recirculation [5].

The flow rates at which the suction and discharge recirculation occurs are dependent on the design of the impeller at the inlet and outlet respectively and may occur at different flow rates as shown in Fig. 4:

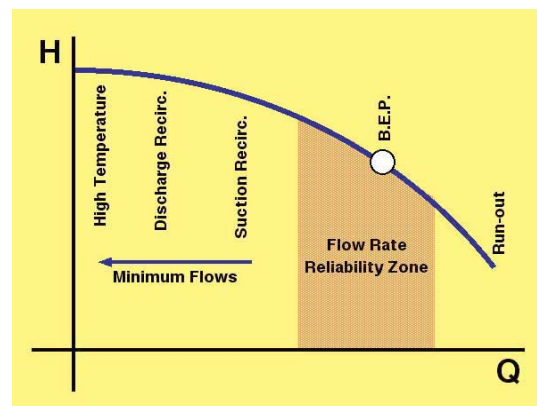

Fig. 4 Points on curve where recirculation can be expected [7].

Like suction recirculation, discharge recirculation causes hydraulic surges and local cavitation at impeller tips. Suction recirculation will produce a loud crackling noise in and around the suction of the pump while discharge recirculation will produce the same characteristic sound as suction recirculation except that the highest intensity is in the discharge volute or diffuser. Suction and discharge recirculation produce cavitation damage to the pressure side of the impeller vanes. Viewed from the suction of the impeller, the pressure side would be the invisible, or underside, of the vane. Guide vanes in the suction may show cavitation damage

from impingement of the back-flow from the impeller eye during suction recirculation. Similarly, the tongue or diffuser vanes may show cavitation damage on the impeller side from operation in discharge recirculation.

## II. EXPERIMENTAL SETUP

Experiments are done on a multipurpose radial flow machine namely GILKES-GH90. This machine is a UK production for research and experimental work which consists of two centrifugal pumps with geometric similarity. One of these pumps can be used as a reaction turbine using the outlet flow of the other pump. These pumps are derived by DC motors with variable speed. The coupled motor to the smaller pump can work as a generator at the turbine test. Speed can be controlled from the front panel which also includes an ammeter and voltmeter for determining motor input power. The power consumed by pumps is measured by a dynamometer balancing the electro motors. Fig. 5 shows the schematic of the experimental setup which consists of a digital flow meter, speed measuring device, pressure gauges for measuring the suction and discharge pressures and a dynamometer for measuring the required torque for rotating the pumps.

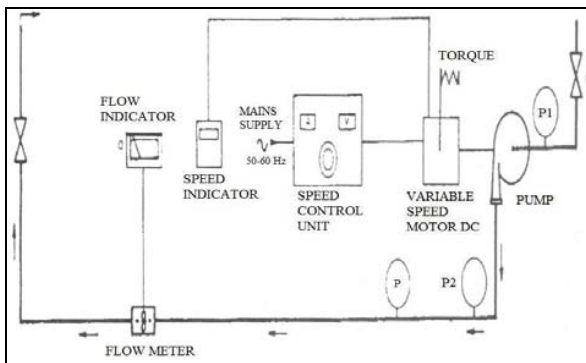

Fig. 5 The schematic of the experimental setups.

The operating characteristics of the studied centrifugal pump are:

The diameter of impeller: 140 mm

Maximum flow rate: 6.5 lit/sec at 3000 rpm

Maximum output head: 28 m at 3000 rpm

*Specific Speed:*

$$N_s = N \frac{\sqrt{Q}}{(h_p)^{3/4}}$$

The  $N_s$  from the above data is calculated:  $N_s = 19.87$  rpm

A stroboscope should be used to monitor the flow patterns among the rotating vanes. A stroboscope, also known as a strobe, is an instrument used to make a cyclically moving object appear to be slow-moving, or stationary and the principle is used for the study of rotating, reciprocating, oscillating or vibrating objects. In its simplest form, a rotating disc with evenly-spaced holes is placed in the line of sight between the observer and the moving object. In electronic versions, the perforated disc is replaced by a lamp capable of emitting brief and rapid flashes of light. The frequency of the flash is adjusted so that it is an equal to, or a unit fraction below or above the object's cyclic speed, at which point the object is seen to be either stationary or moving backward or forward, depending on the flash frequency. By using this setup we are able to measure the operating characteristics such as speed, flow rate, suction and discharge pressures. Our experimental procedure is based on the appearance of the vapor bubbles formation by using a stroboscope and a camera. Experiment was done for five different flow rates in an approximately constant speed ( $N = 2500$  rpm). At each step, the valve was closed gradually and the data's such as flow rate, suction and discharge pressures were recorded. Based on these data's and also the following equations, the head, input and output power, efficiency and also the factors related to cavitation such as NPSHR and Toma Coefficients were determined:

*Head:*

$$h_p = \Phi_2 - \Phi_1 \quad (2)$$

*Input Power:*

$$P_{in} = F \times R \times \frac{2\pi N}{60} \quad (3)$$

*Output Power:*

$$P_{out} = \rho g \times Q \times h_p \quad (4)$$

( $g=9.81$  m/sec<sup>2</sup>)

*Efficiency:*

$$\eta_p \% = \frac{P_{out}}{P_{in}} \times 100 \quad (5)$$

*Required Net Positive Suction Head:*

*Suction Specific Speed:*

$$N_{SS} = N \frac{\sqrt{Q}}{(NPSHR)^{3/4}} \quad (6)$$

As a usual standard for single suction pumps in HI institute:

$$N_{SS} = 174.6$$

Finally:

$$NPSHR = \left( \frac{N\sqrt{Q}}{N_{SS}} \right)^{4/3} \quad (7)$$

Toma Coefficient (Cavitation Coefficient):

$$\sigma = \frac{NPSHR}{h_p} \quad (8)$$

### III. RESULTS AND DISCUSSION

As mentioned above at each step, the operating characteristics of pump such as flow rate, suction and discharge pressures were noted. By using a stroboscope and a camera, the flow patterns among the rotating vanes were photographed. The images have been shown in Fig. 6 with details:



(a)



(b)



(c)



(d)



(e)

Fig. 6 Flow pattern among the rotating vanes of a centrifugal pump;

- a- Q= 4.5 lit/sec, Suction Pressure= -0.6 mH<sub>2</sub>O, Discharge Pressure= 6.3 mH<sub>2</sub>O,
- b- Q= 4.2 lit/sec, Suction Pressure= -0.4 mH<sub>2</sub>O, Discharge Pressure= 10.5 mH<sub>2</sub>O,
- c- Q= 4.0 lit/sec, Suction Pressure= 0.5 mH<sub>2</sub>O, Discharge Pressure= 12.5 mH<sub>2</sub>O,
- d- Q= 3.4 lit/sec, Suction Pressure= -0.8 mH<sub>2</sub>O, Discharge Pressure= 16.0 mH<sub>2</sub>O and
- e- Q= 2.8 lit/sec, Suction Pressure= 0.2 mH<sub>2</sub>O, Discharge Pressure= 19.0 mH<sub>2</sub>O.

Experiment was done for five different flow rates. As it can be seen at higher flow rates vapor bubbles form at suction side of the vanes and the amount of vapor bubbles decreases by decreasing the flow rate and at a critical flow rate (Q = 3.4 lit/sec), bubbles vaporize due to recirculation and at the lowest flow rate (Q = 2.8 lit/sec) there can't be seen any bubbles. Fig. 6-d shows that at Q = 3.4 lit/sec, the bubbles form at both side of the vanes; Thus, both suction and discharge recirculation occur. Fig. 7 shows the result of the operation of the regarded centrifugal pump at different flow rates:



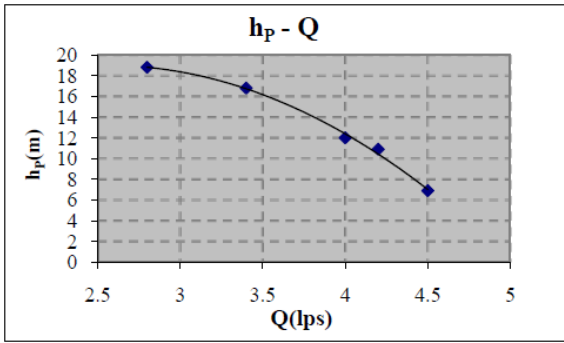

(a)

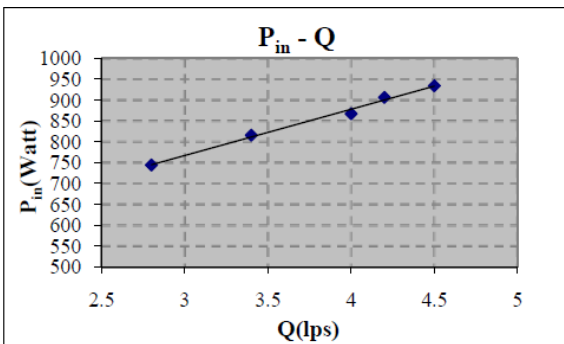

(b)

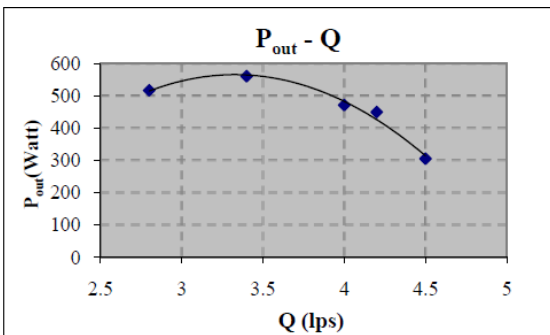

(c)

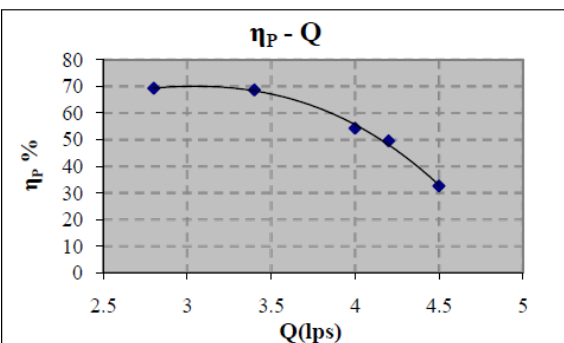

(d)

Fig. 7 Operation of the regarded centrifugal pump; a-Head versus flow rate, b- Input power versus flow rate, c- Output power versus flow rate and d- Efficiency versus flow rate.

As we expected, the head decreases as the flow rate increases. Because increasing the flow rate in an approximately constant speed, decreases the energy delivered to fluid. Also it is obvious that the input power (also known as brake horsepower) increases as the flow rate increases; This is derived from the fact that the force exerted on the vanes increases with the increase in flow rate (for low  $N_s$ ). From (4) it is obvious that the output power (or hydraulic power) depends on the head and flow rate. As it can be seen after the flow rate that bubble vaporization due to recirculation occurs ( $Q = 3.4$  lit/sec), this power decreases. This can be met that increasing the flow rate, decreases the head intensively. Also efficiency decreases with a great slope after the critical flow rate and there is a small change in efficiency between  $Q = 2.8$  lit/sec to  $Q = 3.4$  lit/sec. This is because of the fact that in this interval both input and output powers increase.

Fig. 8 shows the variations of the parameters related to cavitation such as NPSHR (Net Positive Suction Head) and Toma coefficient (or cavitation coefficient):

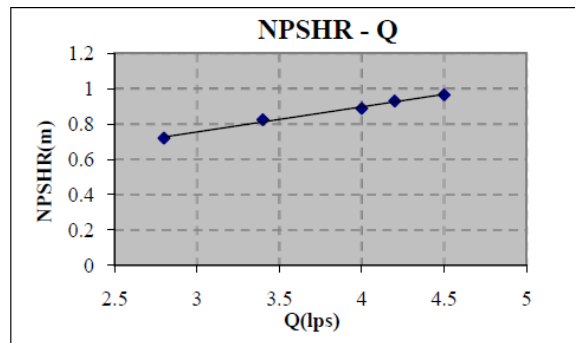

(a)

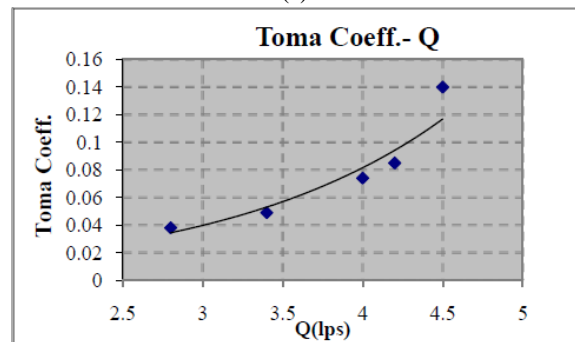

(b)

Fig. 8 Diagram of parameters related to cavitation; a- NPSHR versus flow rate and b- Toma coefficient versus flow rate.

As an important fact, NPSHR depends on velocity components. Thus, as a certain result, the variation of NPSHR is directly proportional to the variation of flow rate and it can be seen obviously in Fig. 8. From (8), Toma coefficient is a function of NPSHR and head; Then as we expected this parameter also increases as the flow rate

increases. Fig. 8 shows that this coefficient increases intensively at higher flow rates and as it can be seen this coefficient is very high when cavitation occurs due to low NPSHA.

#### IV. CONCLUSION

Internal recirculation is a less frequent cause of field troubles but on occasion, it can be quite severe. In this paper, an experiment was done to observe cavitation due to recirculation in a centrifugal pump. A stroboscope was used to monitor this phenomenon. From the figures it was obvious that this kind of cavitation occurs at low flow rates. The results showed that the efficiency and output power decrease as recirculation happens. Both Suction and discharge recirculation can be very damaging to pump operation and should be avoided for continuous operation. The damage due to recirculation occurs on the opposite side of the vane where classical cavitation occurs. Substituting a harder material for the impeller or even bleeding air into the suction of pump can be useful for reducing the rate of cavitation damage. Finally, every impeller design has specific critical flow rate which recirculation occurs. This flow rate is inherent in the design and cannot be changed without modifying the design. Increasing the output capacity of the pump and installing a bypass between the discharge and the suction of the pump can be possible corrective procedures for preventing recirculation to occur.

#### REFERENCES

- [1] J.F., Gülich, "Selection criteria for suction impellers of centrifugal pumps", *J. World Pumps*, January 2001; 28-34.
- [2] A.J., Stepanoff, "Centrifugal and Axial Flow Pumps", John Wiley & Sons, 1948.
- [3] P., Girdhar, and O.Moniz, "Practical Centrifugal Pumps: Design, Operation and Maintenance", Newnes- Elsevier, 2005.
- [4] A.Nourbakhsh, A.Jaumotte, Ch.Hirsch, and Parizi H. B., "Turbopumps and Pumping Systems", Springer, 2008.
- [5] R.Mackay, "Pump Clinic 3: What is Recirculation and Separation", *Kelair Pumps*, May 2006.
- [6] H.Frazer, "Flow Recirculation in Centrifugal Pumps", presented at the ASME Meeting, 1981.
- [7] R.Mackay, "Low flow does not have to mean low reliability", *J. World Pumps*, July 2005; 22-25.