

Sulphur-Mediated Precipitation of Pt/Fe/Co/Cr Ions in Liquid-Liquid and Gas-Liquid Chloride Systems

J. Siame, H. Kasaini

Abstract—The proof of concept experiments were conducted to determine the feasibility of using small amounts of Dissolved Sulphur (DS) from the gaseous phase to precipitate platinum ions in chloride media. Two sets of precipitation experiments were performed in which the source of sulphur atoms was either a thiosulphate solution ($Na_2S_2O_3$) or a sulphur dioxide gas (SO_2). In liquid-liquid (L-L) system, complete precipitation of *Pt* was achieved at small dosages of $Na_2S_2O_3$ (0.01 – 1.0 M) in a time interval of 3-5 minutes. On the basis of this result, gas absorption tests were carried out mainly to achieve sulphur solubility equivalent to 0.018 M. The idea that huge amounts of precious metals could be recovered selectively from their dilute solutions by utilizing the waste SO_2 streams at low pressure seemed attractive from the economic and environmental point of views. Therefore, mass transfer characteristics of SO_2 gas associated with reactive absorption across the gas-liquid (G-L) interface were evaluated under different conditions of pressure (0.5 – 2 bar), solution temperature ranges from 20 – 50 °C and acid strength (1 – 4 M, *HCl*). This paper concludes with information about selective precipitation of *Pt* in the presence of cations (Fe^{2+} , Co^{2+} , and Cr^{3+}) in a CSTR and recommendation to scale up laboratory data to industrial pilot scale operations.

Keywords—CSTR, diffusivity, platinum, selective precipitation, sulphur dioxide, thiosulphate.

I. INTRODUCTION

THE concept of crystallizing metal ions in solution by using sulphur atoms is widely discussed in literature. For instance, most bivalent metal ions such as Fe^{2+} , Cu^{2+} , Zn^{2+} , Ni^{2+} , Pb^{2+} , Sn^{2+} and Mn^{2+} respond well to covalent reaction with SO_3^{2-} ions in which case the solubility of metal sulphates is significantly limited which leads to molecular crystallization, [1]-[5]. The reaction between platinum chloro-complex anions is based on the substitution of *Cl* ions with S^{2-} ions which causes the formation of insoluble metal sulphides, [6]. Dreisinger *et al.* have reported on the application of sodium hydrogen sulphide (*NaHS*) to precipitate Precious Group Metals (PGMs) and gold from a mixed

sulphate/chloride solution, however, *Pt* and *Pd* selectivity were unsatisfactory, [7]. In previous studies, the authors have reported on the ability of thiosulphates ($Na_2S_2O_3$) having two sulphur atoms to react with *Pt* ions selectively, [8].

Currently, the mining industry is facing serious challenges associated with reducing the amount of sulphur (SO_2) emitted to the environment from smelters. Therefore, chemical industries and metallurgical plants are constantly seeking new technologies which can assist to capture SO_2 from flue gases or limit the generation of SO_2 . It is well known that SO_2 in flue gases may cause the formation of acid rain which affects vegetation and soil conditions. Hence the concept of solubilizing SO_2 in chloride media with a view to precipitate PGMs and heavy metals from effluents or leach solutions would be attractive to metallurgical plants. Although it is well known that SO_3^{2-} reacts easily with metal cations to form sulphate precipitate, there is scarcely any literature on the application of sulphur gas to precipitate PGMs later on its solubility characteristics in chloride media. This paper seeks to demonstrate that G-L precipitation process provide greater opportunities for recovering precious metals using small amounts of sulphur and is a viable alternative process to L-L precipitation.

A. Previous Work

The use of H_2S for the (selective) precipitation of valuable metal compounds from leaching solutions has been known to the ore refining industry for long time [9]. Thus far, only limited fundamental research on the phenomenon of absorption of SO_2 in a chloride solution, accompanied by a precipitation reaction of a highly insoluble metal sulphide, has been reported. Mishra & Kapoor [10] attempted to couple the mass transfer theory of absorption of a gas in a reactive liquid and the theory of precipitation dynamics. They investigated the precipitation of cadmium (II) sulphide from a cadmium (II) chloride solution in a bubble column reactor. The absorption of pure H_2S in a diluted cadmium chloride solution could, according to their own conclusions, be described by assuming that the absorption of H_2S into the solution was accompanied by an instantaneous irreversible reaction between H_2S and the metal ion. The mass transfer model used in the study was based on the Higbie penetration model [11]. It must be noted however that the cadmium chloride concentration applied was so low, that the influence of the

J. Siame is with the Dept. of Chemical & Metallurgical Engineering, Tshwane University of Technology, P/B X680, Pretoria 0001, South Africa. (Corresponding author: Tel.: +27-79-848-4070; Fax: +27-12-382-3532; E-mail: jsiamem@yahoo.co.uk).

H. Kasaini was with Tshwane University of Technology, P/B X680, Pretoria 0001, South Africa. He is now at 5 rue de Panazol, Feytiat, France. (Mobile phone: +33 677 262838; E-mail: henry_kasaini@yahoo.com).

reaction of the absorption rate was rather small therefore; the reliability of their conclusions might be debatable.

The absorption of H_2S into a diluted copper sulphate solution was investigated by Oktaybas et al. [12], who used an experimental setup identical to the one used by Mishra and Kapoor [10]. Oktaybas et al. also used the Higbie penetration model and the assumption of an irreversible instantaneous reaction between H_2S and Cu^{2+} to explain the results. Although the agreement between theory and experiment was good for pH values larger than 2, the model did not explain the observed dependency of the absorption rate on the pH (i.e. observed pH values below 2). Oktaybas *et al.* [12] described the decrease of the absorption rate with decreasing pH to the shift in the $H_2S/HS^-/S^{2-}$ equilibria and the resulting lower S^{2-} concentration.

Broekhuis et al. [13] investigated the removal of dilute H_2S from a gas stream using copper and zinc sulphate solutions in a stirred cell reactor. The rate of absorption of H_2S in a copper sulphate solution was found to be gas phase mass transfer limited, while the absorption rate of H_2S into a zinc sulphate solution was found to be a function of the amount of unconverted zinc sulphate. They did not attempt to present a fundamental description of the simultaneous absorption and precipitation of H_2S in metal sulphate solutions. Maat ter et al. [14] investigated the removal of dilute H_2S from a gas stream using copper, zinc and iron sulphate solutions in a bubble column reactor. The $CuSO_4$ solution was shown to be the most suitable solution for H_2S removal. The laboratory experiments indicated that the absorption of H_2S in a $CuSO_4$ solution, at the experimental conditions tested is a gas phase mass transfer limited process. In the same study the applicability of a $CuSO_4$ solution for the removal of H_2S from a biogas stream was successfully demonstrated on a pilot plant scale.

Precipitation of PGMs with solutions containing sulphur atoms has been reported in literature by several researchers. Selective precipitation of PGMs from mixed chloride solutions using ammonium chloride solution (NH_4Cl) has been reported by Habashi, [15] and Schreier, [16] and a longer contact time and high temperatures were found to be having a negative influence on precipitation process [16]. Increased contact time results in co-precipitation of impurities and thus reduces purity and at higher temperatures recovery is compromised because the solubility of PGMs increases. It is known that more or less all PGM-chloride complexes are susceptible to hydrolysis, especially at higher temperatures, and this can have influence on the completeness of the reaction and the separation effect [16]. The use of sodium formate to precipitate precious metals from acidic media has also been reported as an alternative to zinc reduction process, and the process is pH dependent and it is also not easy to precipitate iridium [17].

Kasaini et al. [18] performed some tests which showed that when sulphur atoms are immobilized on the Activated Carbon (AC) surface, the affinity properties towards Pd anions are developed on the surface of carbons in solution. The concepts above support the proposition that the presence of sulphur atoms in chloride solution will induce a selective reaction with PGMs and base metals depending on the reactivity and charges of the ions in solution.

Unfortunately, not much is known about the exact reaction rate of S^{2-} with the metal ions, although some precipitation

models are available in literature. The reaction rate at which S^{2-} and metal ions react to form solid metal sulphide is determined by two processes: firstly, the formation of new metal sulphide nuclei and, secondly, the growth of existing precipitates. These precipitation models state that the rate of formation of new precipitate particles is a highly non-linear function of the concentration of the reacting components [19], [20]. Furthermore, the rate of growth of existing particles seems to be the result of a number of process steps (like diffusion of reacting components to the precipitate surface and the rate at which the ions are incorporated in the crystal), all of which can be rate limiting.

The purpose of the present work is to present the reactive absorption data for sulphur-mediated precipitation of Pt/Fe/Co/Cr ions in liquid-liquid and gas-liquid chloride systems. L-L precipitation tests were performed to determine the amount of sulphur atoms (from $Na_2S_2O_3$) required to precipitate platinum, Iron, cobalt and chromium ions and establish reaction kinetics. In subsequent tests (G-L precipitation) an equivalent amount of sulphur was introduced into the mixed chloride solutions using SO_2 feed gas at high pressure (0.5 – 2 bar) and stirring speeds in the range of 2-16 s^{-1} .

B. Theory

The rate of reaction in the solution phase where metal ions react with DS atoms can be evaluated by using the n -th order kinetics as in (1). The n -th order kinetics makes it possible to determine the order of a reaction and rate constant. A differential method of data analysis may be applied to determine the rate equation by plotting concentration (C_A) versus time (t), [21]. Equation (1) shows the rate equation

$$-r_A = dC_A/dt = kC_A^n \quad (1)$$

where dC_A/dt is the rate of disappearance of species A in solution, C_A is the concentration at time t , while n is the order of the reaction. A plot of $\log(dC_A/dt)$ versus $\log C_A$ will yield a straight line with a slope (n) and intercept ($\log k$) as shown by (2).

$$\log(-dC_A/dt) = \log k + n \log C_A \quad (2)$$

From the gas absorption point of view, it is necessary to establish the mass transfer characteristics of SO_2 from the bulk gas phase into mixed chloride solvents. The presence of metal ions in the solvent would accelerate the uptake of sulphur atoms from the gas phase through a chemical reaction. Resistance to diffusion of a species in a pure gas phase is negligible. Therefore, in order to model the mass transfer of sulphur dioxide, it is necessary to generate the absorption kinetics data with or without an accompanying chemical reaction.

The overall mass transfer of sulphur atoms from the bulk gas phase into the chloride solution (mol s^{-1}) may be expressed by (3).

$$dm/dt = 1/\left(\frac{1}{k_L} + \frac{1}{k_G}\right)a(C_{A,i} - C_{A,L}) = K \cdot a(C_{A,i} - C_{A,L}) \quad (3)$$

where $\left(\frac{1}{k_L} + \frac{1}{k_G}\right)$ is the overall mass transfer resistance, K and $1/k_G \approx 0$ since the gas phase is pure with only sulphur atoms. Rate of mass transfer may be rewritten to take into account the constant volume of the solution ($\text{mol m}^{-3} \text{s}^{-1}$) and interfacial area ($\text{m}^2 \text{m}^{-3}$) exposed to a pure gas phase as shown by (4) and (5);

$$d\left(\frac{m}{V}\right)/dt = dC_{A,L}/dt = K_L a(C_{A,i} - C_{A,L}) \quad (4)$$

and then reduced to (5)

$$dC_L/dt = K_L a(C_i - C_L) \quad (5)$$

where, K_L is the mass transfer resistance in the liquid phase. The concentration gradient can be correlated to the pressure drop of the gas during absorption [22].

According to Rodriguez-Sevilla *et al.*, [23] the dissociation of SO_2 in acid solutions was less than 5% under the conditions they had studied. The dissociation of SO_2 in aqueous solution was proposed by Dagaonkar *et al.*, [24] as in (6) – (8)

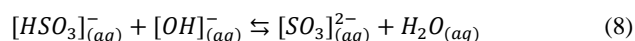
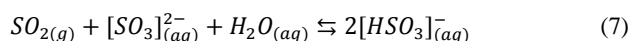
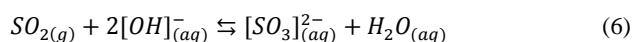

While Rodriguez-Sevilla *et al.*, [23] showed that SO_2 dissociation in aqueous solutions is given by (9)

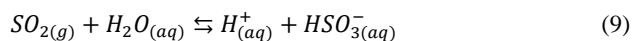

On the basis of (6) and (8), SO_3^{2-} ions are the main product when sulphur dioxide reacts with water (OH^-) molecules in a few stages, [24]. From this view, it is possible to correlate the absorption rate of SO_2 with SO_3^{2-} in the bulk solution as shown in (10)

$$N = C_{SO_2}^* \cdot a \cdot \sqrt{D_{SO_2} \cdot k \cdot C_{SO_3^{2-}}} \quad (10)$$

where N is the absorption rate of SO_2 ($\text{mol m}^{-3} \text{s}^{-1}$) while $C_{SO_2}^*$ and D_{SO_2} are interfacial concentration and diffusivity in aqueous phase respectively; a is the interfacial area, k is the rate constant for the conversion of SO_2 atoms into SO_3^{2-} ions at the interface.

II. MATERIALS AND METHODS

A. Materials

Analytical standard solutions of platinum (H_2PtCl_6), iron ($FeCl_2$), cobalt ($CoCl_2$) and chromium ($CrCl_3$) chloride, 32% HCl acid solution and sodium thiosulphate ($Na_2S_2O_3$)

solutions were purchased from Merck Chemicals (Pty) Ltd in South Africa. However, 99.9% SO_2 gas (pressurized gas cylinders) was purchased from AFROX (Pty) Ltd, South Africa.

B. Liquid-Liquid Precipitation

Liquid-liquid batch tests were carried out in 1.0 L reaction vessel equipped with a perforated lid. The reactor vessel consisted of the following: electrical stirrer, heating element (hot plate), thermometer and pH meter. The reactor vessel is shown in Fig. 1 and the operation conditions of the reactor vessel are listed in Table I.

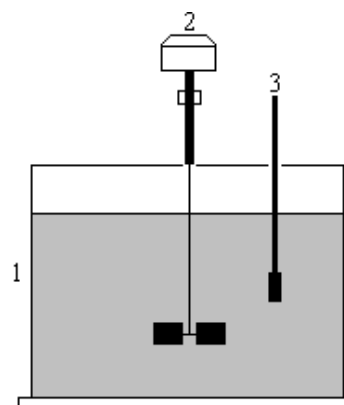

Fig. 1. Schematic diagram of experimental setup for liquid-liquid precipitation under ambient conditions: stirred vessel reactor (1); electric stirrer (2); pH meter (3).

TABLE I
EXPERIMENTAL CONDITIONS

Temperature	25 °C
Liquid volume	$1 \times 10^{-3} \text{ m}^3$
Stirrer speed	$2 - 16 \text{ s}^{-1}$
Initial conc. of $Na_2S_2O_3$	0.05 - 1.0 M
Feed-precipitant ratio	01:01
Contact time	24 hrs
Metal ions conc. (Pt, Fe, Co, Cr)	100 mgL^{-1}
HCl conc.	1 - 4 M

A mixture of Pt and base metal (Fe^{2+} , Co^{2+} and Cr^{3+}) solution was prepared in equal concentration (100 mg/L) in 1M HCl acid solution. Sodium thiosulphate ($Na_2S_2O_3$) solution was used as a precipitant for metal ions in chloride solution. The initial concentration of $Na_2S_2O_3$ solution was varied in the range 0.05 – 1.0 M. The ratio of the feed solution to the precipitant solution was kept constant at 1:1 while contact time was averaged 24 hrs. After equilibrium had been achieved, the precipitate was filtered off and a clear filtrate solution was analyzed for metal ions using the inductively coupled plasma optical emission spectrometry (ICP - OES),

instrument (Shimadzu model ICPE - 9000). The main objective of liquid-liquid precipitation tests was to determine the amount of sulphur (from $Na_2S_2O_3$) required to precipitate platinum, iron, cobalt and chromium ions and also to establish the reaction kinetics. In subsequent tests (G-L precipitation), an equivalent amount of sulphur would be introduced into the mixed chloride solution using SO_2 feed gas at high pressure.

C. Gas-Liquid Precipitation

The experiments were carried out in a thermostatted 2.0 L Buchi reactor of glass and stainless steel as shown in Fig. 2. A six bladed turbine stirrer was located centrally in the liquid at a height above the reactor bottom equal to half the reactor diameter. Three symmetrically mounted glass baffles increased the effectiveness of stirring and prevented the formation of a vortex. The pressure and temperature transducers were connected to a Squirrel SQ 1000 series Data Logger and Mercer Premium computer, enabling data collection and programmed reactor operation. The reactor dimensions are given in Table II.

TABLE II
REACTOR DIMENSIONS

Reactor diameter	0.082 m
Reactor volume	$1.5 \times 10^{-3} \text{ m}^3$
Gas -Liquid contact area	$5.28 \times 10^{-3} \text{ m}^2 \text{ m}^{-3}$
Liquid impeller type	Six bladed turbine, 0.05m diameter
Gas impeller type	Three bladed turbine, 0.05m diameter

The reactor was initially degassed by purging with nitrogen gas. Thereafter, the reactor was loaded with a specific solvent (with or without metal ions). The starting solution was allowed to equilibrate with its own saturated vapour at room temperature. The feed gas (SO_2) was introduced into the reactor from a high pressure cylinder possessing a regulator. The operating conditions of the stirred cell reactor are listed in Table III.

TABLE III EXPERIMENTAL CONDITIONS

Temperature	20 - 50 °C
Initial pressure	$1 \times 10^5 \text{ Pa}$
Liquid volume	$1 \times 10^{-3} \text{ m}^3$
Gas	N_2 , purity >99.5% SO_2 , purity >99.5%
Stirrer speed	2 - 16 s^{-1}

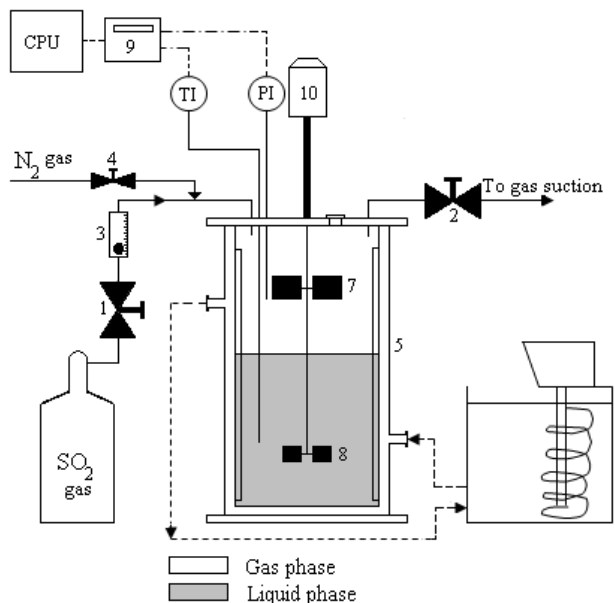

Fig. 2. Stirred cell reactor: SO_2 gas inlet and outlet valves (1, 2); SO_2 gas flowmeter (3); N_2 gas inlet valve (4); stirred cell reactor (5); thermostat water bath (6); gas stirrer (7); liquid stirrer (8); data logger (9); magnetic coupling mixer (10).

Gas filling stopped after a specific initial pressure was reached. Subsequently, the stirrer was started and the pressure drop in the reactor was recorded with time. At equilibrium, the pressure drop levelled off and a solution sample was taken from the bulk solution to determine the maximum absorption capacity of SO_2 and amount of metal ions precipitated.

Under reactive absorption tests, a solvent containing platinum ions was used as the starting solution to assess the extent to which platinum assisted absorption. The amount of sulphur sequestered in metal-rich and metal-free chloride solvents (>1M HCl acid) was recorded. The rate of metal precipitation was not quantified due to difficulties (lack of a sampling gun) associated with solution sampling at high pressure. However, the final assay of metals in solution at equilibrium was compared with data from liquid-liquid precipitation batch tests. In any case, this study was designed to generate and compare scientific data on selective precipitation of Pt in liquid-liquid and gas-liquid systems. Preliminary study showed that application of $Na_2S_2O_3$ as a precipitant for Pt in a mixed chloride solution containing Fe^{2+} , Co^{2+} and Cr^{3+} ions was both selective and favourable. This result implied that sulphur atoms interacted preferentially with platinum ions. Therefore, the concept of using a gas feed as a source of sulphur atoms was conceived out of the desire to utilize SO_2 flue gases from smelters or roaster plants which are readily available.

III. RESULTS AND DISCUSSION

A. Liquid-Liquid Precipitation in Chloride System

A.1 Effect of $\text{Na}_2\text{S}_2\text{O}_3$ Concentration

According to previous studies on speciation chemistry for platinum ions as a function of chloride concentration, platinum may exist as chloro-complex anions with or without water ligands (i.e., $\text{Pt}(\text{H}_2\text{O})_3\text{Cl}_2^{-3}$, $\text{Pt}(\text{H}_2\text{O})_3\text{Cl}_3^{-2}$, PtCl_6^{-2}), [25], [26]. The most labile ions are those without water ligands in the molecular structure at high chloride concentration. In this study, the chloride concentration was greater than 1M, which implied that negatively charged species of platinum ions existed in solution. Therefore, dissolved sulphur (S^{2-}) reacts with platinum by replacing the chloride atoms in the nucleophilic chloro-complex structure and subsequently crystallizing platinum as a sulphide compound (PtS).

The concentration of sulphur atoms in the liquid precipitant depends on the initial dosage of the thiosulphate reagent ($\text{Na}_2\text{S}_2\text{O}_3$) as shown in Table IV, which was varied between 0.05 and 1 M. Figs. 3, 4 and 5 illustrates the precipitation kinetics of Pt in the presence of base metal ions (Fe^{2+} , Co^{2+} and Cr^{3+}). The rate of Pt precipitation was found to be faster at low thiosulphate concentration (0.05 M). However, the amount of platinum recovered from all chloride solutions averaged above 99% in short contact period (>10 min) as shown in Fig. 6.

The first and second order kinetics did not fit the precipitation data in Figs. 3, 4 and 5. Hence the expressions for the n -th order kinetics, as described by combining (1) and (2) was used to evaluate the order (n) and rate constant (k) of precipitation as shown by Fig. 7. The order of reaction for platinum was found to be approximately unit ($n = 1.23$). This result implies that the reaction between sulphur ions and Pt chloro-complex anions is spontaneous and proceeds rapidly at low $\text{Na}_2\text{S}_2\text{O}_3$ concentration. Platinum ions are nucleophilic and require lots of chloride molecules for stability. This implies that at low Cl^- concentration, water ligands easily bond with Pt ions. Therefore, in the presence of excess negatively charged sulphur ions (S^{2-}), water ligands as well as Cl^- ions may be replaced chemically within the chloro-complex structure in order to crystallize the platinum atoms. By contrast, cations (Fe^{2+} , Co^{2+} and Cr^{3+}) form stable structures with chloride molecules and therefore chemical reduction with S^{2-} is a slow process. It is therefore possible to separate Pt ions from base metal ions before disposal of heavy metal sulphide precipitates.

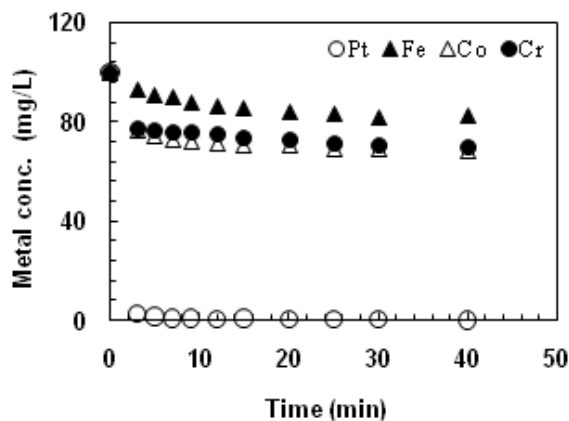

Fig. 3. A plot of metal concentration vs. contact time. Precipitation kinetics of platinum and base metals from a mixed solution in liquid-liquid batch test at ambient conditions, [HCl] = 1 M, [$\text{Na}_2\text{S}_2\text{O}_3$] = 1 M].

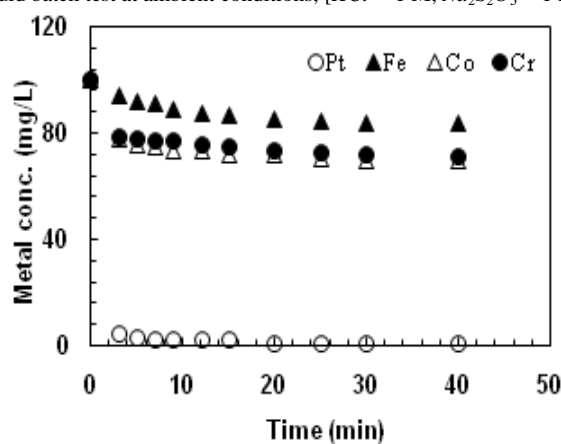

Fig. 4. A plot of metal concentration vs. contact time. Precipitation kinetics of platinum and base metals from a mixed solution in liquid-liquid batch test at ambient conditions, [$\text{Na}_2\text{S}_2\text{O}_3$] = 0.1 M and [HCl] = 1 M].

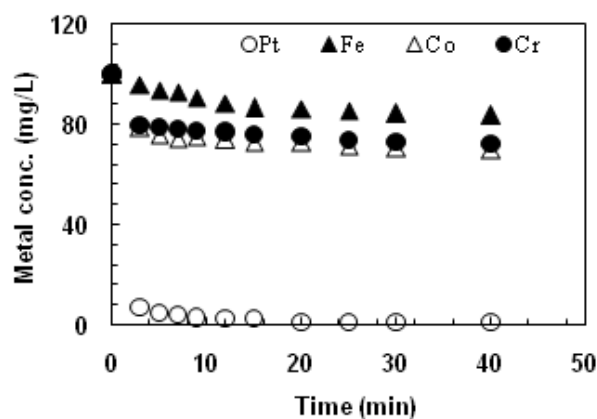

Fig. 5. A plot of metal concentration vs. contact time. Precipitation kinetics of platinum and base metals from a mixed solution in liquid-liquid batch test at ambient conditions, [$\text{Na}_2\text{S}_2\text{O}_3$] = 0.05 M and [HCl] = 1 M].

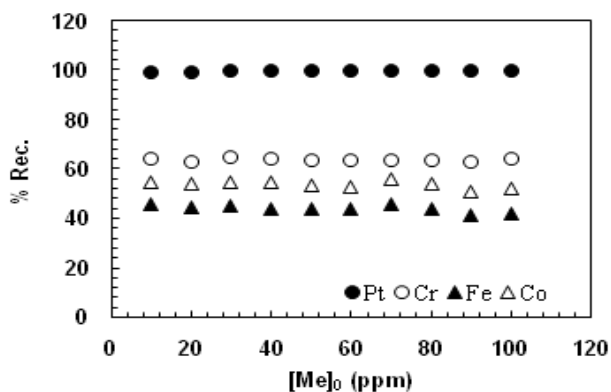

Fig. 6. A plot of percentage recovery vs. $[Me]_0$. Effect of $[Me]_0$ on recovery (%) of platinum and base metals from a mixed solution (1M HCl) in liquid-liquid batch test after 24 h, $[Na_2S_2O_3] = 0.05$ M, at ambient conditions.

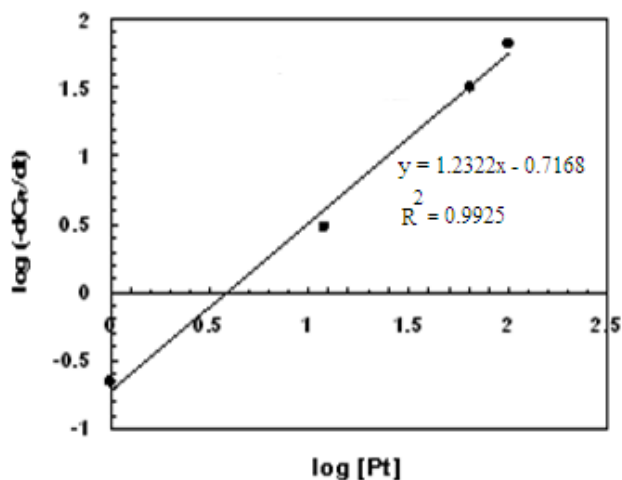

Fig. 7. A plot of $\log(-dC_{Pt}/dt)$ vs. $\log [Pt]$. Determining n value so as to determine k value of platinum using Differential Method of Data Analysis at ambient conditions. $[Na_2S_2O_3] = 0.05$ M and $HCl = 1$ M].

A.2 Effect of HCl Concentration

According to the speciation diagrams of $Pt(II)$ in chloride solutions, [26] - [28] the most abundant $Pt(II)$ species are chloro-complex anions (HCl conc. >0.01 M). Metal speciation of platinum in the bulk solution is dependent on chloride ion concentration. For solution with pH values ranging from 2.7-2.9, platinum exists as $PtCl_3^-$ (15%), $PtCl_2$ (65%), and $PtCl^+$ (20%) complexes.

The concentration of sulphur atoms in the liquid precipitant depends on the concentration of HCl (Fig. 8) which was varied between 1- 4 M. Fig. 8 illustrates the two types of absorption profiles which were observed at different acid strength; namely, a rapid absorption of $Pt(II)$ in the first 3 min followed by a slow absorption process leading to equilibrium state. In the initial absorption stage, a mass-transfer-controlled rate was assumed and a slow absorption stage was attributed to diffusivity. The results showed that the rate of Pt precipitation was found to be faster at high HCl concentration (4 M). For comparison purposes, the effect of HCl concentration on the

mass of Pt precipitate ($PtS + S$) was also studied (Fig. 9). As shown in Fig. 9, the amount of Pt in the reactor vessel discharge solution increased significantly with increase in HCl concentration up to 8.4 g (Pt recovery 99.5%) at ambient conditions. This result is attributed to the fact that the rate of Cl^- ions displacement from Pt anion complexes by S^{2-} atoms increases with an increase in Cl^- ions in the solution.

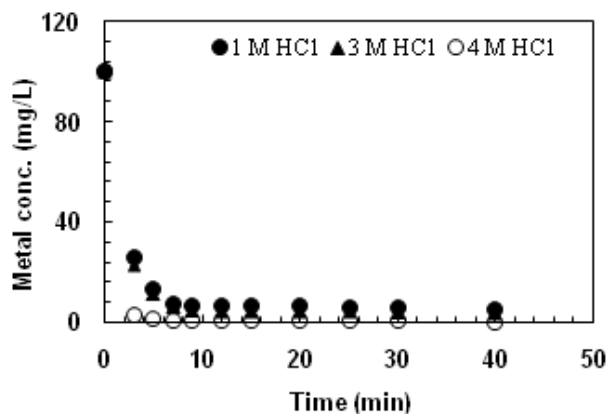

Fig. 8. A plot of metal concentration vs. contact time. Precipitation kinetics of platinum at different acid strength (1, 3 and 4 M, HCl) in liquid-liquid batch test at ambient conditions $[Na_2S_2O_3] = 0.05$ M].

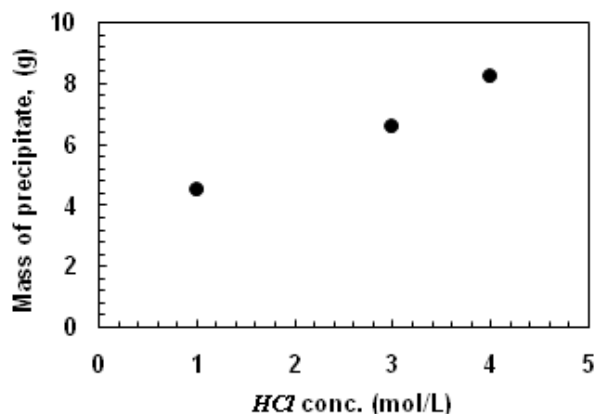

Fig. 9. A plot of mass of precipitate ($PtS + S$) vs. acid concentration (HCl), contact time = 24 h. Effect of HCl concentration on mass of precipitate. $[Na_2S_2O_3] = 0.05$ M, at ambient conditions.

A.3 Determination of Separation Factors (β)

Fig. 10 shows that the separation factor for the process indicates a good separation between platinum and base metals. Separation factor was found to be of the following order ($\beta_{Pt/Fe} > \beta_{Pt/Cr} > \beta_{Pt/Co}$). If the contact time increases, then separation factor is compromised.

Selective precipitation reaction (Liquid-Liquid System) between sulphur atoms (from the precipitant $Na_2S_2O_3$) and platinum ions in hydrochloric acid media is evidence enough that sulphur-bearing gases could be used to precipitate Pt selectively in a more efficient and economical way.

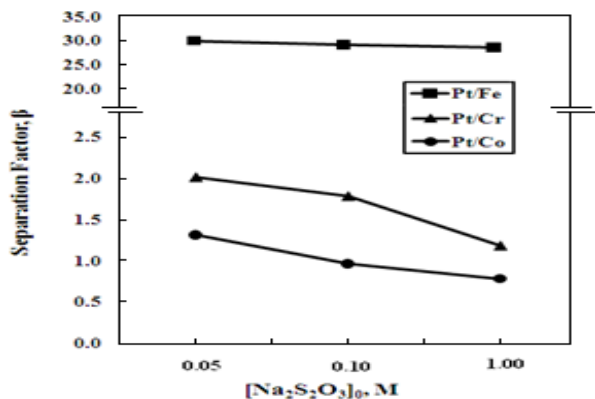

Fig. 10. Separation factors ($\beta_{Pt/Me}$) of metals at various initial concentrations of sodium thiosulphate $[Na_2S_2O_3]_0$ in solution.

B. Gas-Liquid Precipitation in Chloride Systems

B.1 Determination of Mass Transfer Coefficient

Fig. 11 illustrates the absorption kinetics of SO_2 in 4M HCl acid solution at 20 °C and a gas pressure of 1 bar.

The gas pressure dropped from 1.0 to 0.22 bars within approximately 20 min of contact time (Fig. 12). The corresponding increase in sulphur concentration is shown as a mirror image of the pressure drop. The average absorption of SO_2 after 20 min was 0.018 mol/L. This data implies that physical absorption of SO_2 in concentrated HCl solution is possible at room temperature. The reason why we carried out absorption tests at high HCl acid strength was because the final solution from the elution circuit of platinum recovery comes at high acid concentrations in the range of 3.5 – 4.0 M, HCl . From literature, it is known that platinum can only be precipitated out of the solutions at high HCl concentration (>3.5 M) using sodium thiosulphate. Therefore, in this study the overall focus was to attempt to introduce sulphur atoms in solution using a carrier gas as opposed to a liquid carrier. The mass transfer coefficient of SO_2 in HCl acid solution was evaluated by using Fig 11. The mass transfer coefficient values are shown in Table I.

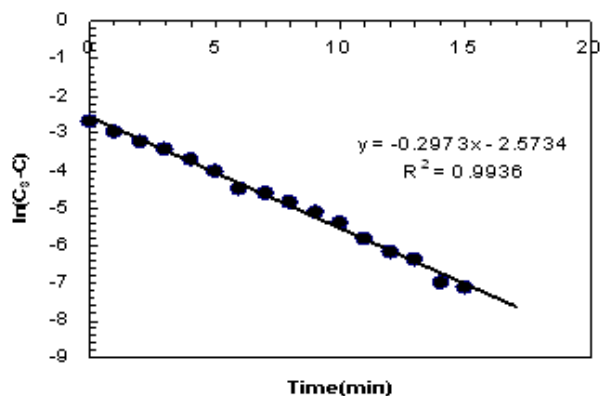

Fig. 11. A plot of $\ln(C_s - C_l)$ vs. Time: Evaluation of Mass transfer coefficient for physical absorption of SO_2 into 4 M HCl acid solution.

TABLE IV
MASS TRANSFER COEFFICIENTS WITH AND WITHOUT METALS IN SOLUTION (GAS-LIQUID BATCH TESTS)

System	K_{La} (min^{-1})	$[S^0]_{equiv.}$ (mol/L)
Physical absorption	2.917	0.0164
Absorption with Pt	3.364	0.0188
Absorption with Pt/Fe	3.675	0.0181

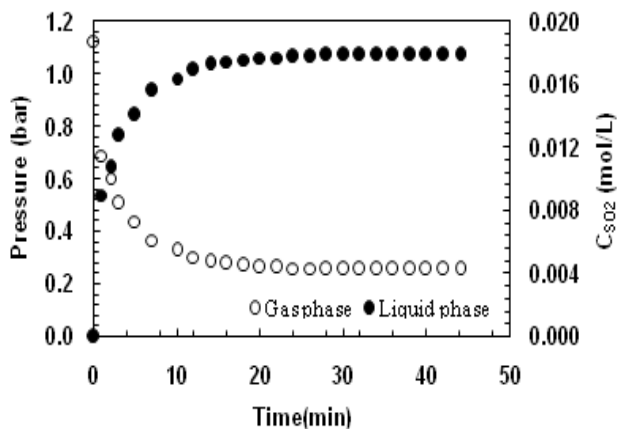

Fig. 12. A plot of pressure drops of SO_2 vs. time. Physical absorption of SO_2 into acid media at 20°C. $[HCl] = 4$ M. In Gas phase sulphur was calculated from Ideal gas law.

B.2 Effect of HCl Concentration on Physical Absorption of SO_2

The results indicated that the increase in HCl concentration adversely affected the physical absorption of SO_2 . This result (Fig. 13) was attributed to the salting out effect of gaseous molecules in the acid solution and also probably due to an increase in the interfacial tension at the liquid surface.

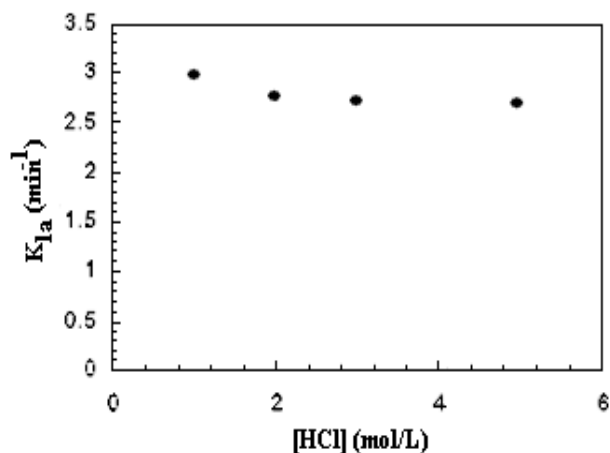

Fig. 13. A plot of mass transfer coefficients in liquid phase vs. $[HCl]$.

B.3 Effect of Temperature on SO_2 Absorption

Fig. 14 illustrates that SO_2 solubility was slightly affected by temperature in the range 20 – 40 °C. It is well known that physical absorption of gases is affected by increase in temperature due to the shift in the vapour liquid equilibrium. Thermodynamically, molecules prefer to exist in the gas phase at high temperatures.

Table II illustrates the calculated values of diffusion coefficient, D_L , from (10) and rate constant, k_R at different temperatures. From the results of Table II, the diffusion coefficient values, D_L , of SO_2 into metal solution in chloride systems increased with temperature as expected and the relationship between diffusion coefficients of SO_2 in metal solution and the temperature is linear, [29], [30].

The k_R values decrease with temperature. This is due to the fact that k_R is a “phenomenal” constant which corresponds not only to the reaction between SO_2 and metal ions in the solution, but to the total phenomenon where the uptake of SO_2 by metal ions in the solution takes place first, [31].

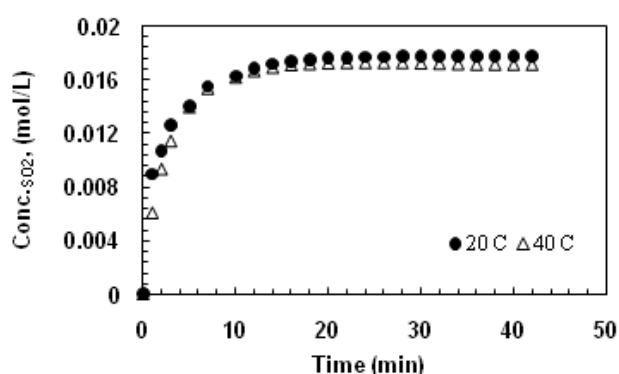

Fig. 14. Dependence of Concentration of SO_2 on time at different temperatures. The effect of temperature on physical absorption of SO_2 in chloride media at 20 and 40 °C.

TABLE V

DIFFUSION COEFFICIENTS, D_L , OF SO_2 , RATE CONSTANTS, k_R , FOR THE NTH ORDER REACTION BETWEEN SO_2 AND METAL SOLUTIONS IN CHLORIDE SYSTEMS IN THE GAS-LIQUID INTERFACE AS A FUNCTION OF TEMPERATURE

T (K)	D_L ($10^{-9} \text{ m}^2 \text{ s}^{-1}$)	k_R ($\text{m}^3 \text{ mol}^{-1} \text{ s}^{-1}$)
293.15	2.36	8.81
303.15	2.89	7.46
313.15	3.43	6.10

B.4 Reactive Absorption of SO_2 in the Presence of Pt/Fe/Co/Cr ions

In the presence of platinum ions (Fig. 15), the solubility of SO_2 was enhanced slightly due to the chemical reaction with platinum to form platinum sulphide ($Pt-S$ bond formation). The increase was not significant because the stoichiometric amount of sulphur atoms required to react with the traces of platinum ($5.0 \times 10^{-4} \text{ mol/L}$) in solution was small. Initial

concentration of Pt was the limiting factor in the reactive solubility of SO_2 .

As it can be seen from Table I, the presence of metal ions in the solution has an effect on mass transfer coefficient. The resistance to mass transfer slightly increases as more metal ions are added into a solution. This could be attributed to the fact that interface area decreases due to the presence of solid particles in the liquid phase. The formation of solid particles could also influence the effective interfacial area.

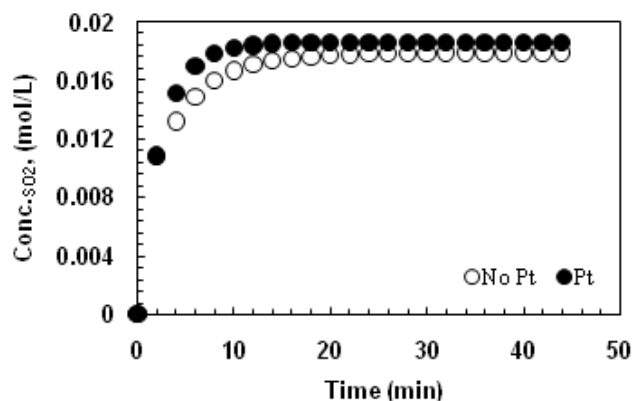

Fig. 15. A plot of SO_2 concentration vs. mixing time. Reactive absorption of SO_2 in solution with or without Pt ions. $[HCl] = 4 \text{ M}$.

B.5 Effect of Pressure on SO_2 Absorption

It is evident from Fig. 16 that the initial pressure has an effect on gas solubility. As the initial pressure is raised, an increase in the absorption rate of SO_2 is noticed.

This is seen from the results of Table III, as initial gas pressure of SO_2 is increased, the diffusion coefficient values of SO_2 into metal ions solution in chloride systems are increased.

TABLE VI

DIFFUSION COEFFICIENT, D_L , OF SO_2 , RATE CONSTANTS, k_R , FOR THE NTH ORDER REACTION BETWEEN SO_2 AND METAL IONS SOLUTIONS IN CHLORIDE SYSTEMS IN THE GAS-LIQUID INTERFACE AS A FUNCTION OF PRESSURE

Pressure (Bar)	D_L ($10^{-9} \text{ m}^2 \text{ s}^{-1}$)	k_R ($\text{m}^3 \text{ mol}^{-1} \text{ s}^{-1}$)
0.5	1.095	16.60
1.0	1.622	9.815
1.5	1.987	8.52
2.0	2.221	5.2

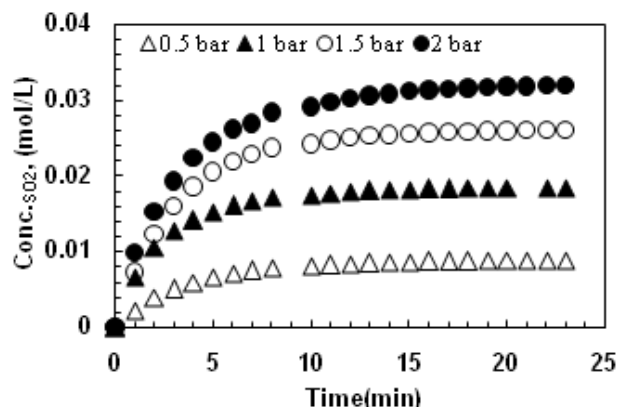

Fig. 16. A plot of SO_2 concentration vs. time. The effect of initial pressure of SO_2 at ambient conditions. $[HCl] = 4 M$.

B.6 Precipitation of Pt ions with SO_2 Gas and $Na_2S_2O_3$: Comparison

Table IV shows a comparison between the use of $Na_2S_2O_3$ and SO_2 gas to recover Pt from hydrochloric media. Kasaini *et al.*, [13] reported that sodium thiosulphate can precipitate platinum in hydrochloric acid media at ambient conditions. Therefore, liquid-liquid precipitation experiments (batch tests) were performed to verify these findings. Thereafter, the results are compared with the results obtained when sulphur dioxide is used. Separation factors for both processes is fairly good, but a short contact time is recommended for a better separation factor as other metals tend to precipitate more as contact time is prolonged.

TABLE VII
A COMPARISON BETWEEN THE USE OF $Na_2S_2O_3$ AND SO_2 GAS

	$Na_2S_2O_3$	SO_2 gas
Platinum solution vol. (L)	0.5	1.0
Initial Pt conc. (mg/l)	100	100
Final Pt conc. (mg/l)	2.3	1.5
$Na_2S_2O_3$ conc. (M)	0.05	-
Volume precipitant (L)	0.15	0.5
Contact time (min)	40	40
Pressure (bar)	-	1
Sulphur required (moles)	0.10	0.02

IV. CONCLUSION

From selective batch precipitation of platinum in L-L system using $Na_2S_2O_3$ solution, above 99.5% of platinum was precipitated within the hydrochloric acid concentration range of 1–4 M. Precipitation was confirmed by the evidence of platinum in the precipitate according to the XRF analysis. The average selectivities of platinum to base metals at an average concentration of 100 mg/L of Pt and base metals were about 29 for Pt/Fe, 1.7 for Pt/Cr and 1 for Pt/Co.

On the basis of SO_2 solubility data (G-L system) both in physical and reactive absorption conditions, we concluded that

it is possible to introduce significant amounts of sulphur atoms in HCl solutions. If there are platinum ions in the solution, the presence of sulphur atoms will trigger off a precipitation reaction between sulphur and platinum ions.

From the modelling point of view, solubility of SO_2 in HCl media was adequately described by the two-film model. Therefore, the rate constants can be evaluated and used in predicting the correct size of industrial contactors.

The results from this work confirmed the concept that it is possible to replace liquid precipitants such as sodium thiosulphate with SO_2 gas. The benefits of using SO_2 gas from smelter flue gases in downstream precipitation of Pt and base metals are enormous and ameliorate the adverse effects of SO_2 on the environment.

NOMENCLATURE

a	gas – liquid interfacial area ($m^2 m^{-3}$ liquid)
C_A	concentration of species A ($mol m^{-3}$)
$C_{SO_2}^*$	interfacial concentration of SO_2 ($mol m^{-3}$)
$C_{A,i}$	gas concentration in liquid at the interface ($mol m^{-3}$)
$C_{A,L}$	gas concentration in liquid bulk phase ($mol m^{-3}$)
D_{L,SO_2}	diffusivity of SO_2 in the liquid phase ($m^2 s^{-1}$)
dm/dt	rate of mass transfer ($mol s^{-1}$)
K	overall mass transfer resistance
K_L	mass transfer resistance in liquid phase
k_R	rate constant
k_L	mass transfer coefficient in liquid phase ($m^3 m^{-2} s^{-1}$)
k_G	mass transfer coefficient in gas phase ($m^3 m^{-2} s^{-1}$)
N	absorption rate ($mol s^{-1}$)
$-r_A$	rate of reaction dC_A/dt ($mol s^{-1}$)
t	time (s)
T	temperature (K)
$\beta_{Pt/Fe}, \beta_{Pt/Cr}, \beta_{Pt/Co}$	Separation factors between Pt and Fe, Pt and Cr, Pt and Co

SUBSCRIPT AND SUPERScript

A	species A
i	interface
n	order of reaction
G	referring to the gas phase
L	referring to the liquid phase

ACKNOWLEDGMENT

The authors are grateful to Tshwane University of Technology and the Department of Science & Technology (Innovation and Technology Fund), South Africa for financial support.

REFERENCES

- S. Ebrahimi, R. Kleerebezem, M. C. M. van Loosdrecht, and J. J. Heijnen, "Kinetics of the reactive absorption of hydrogen sulphide into aqueous ferric sulphate solutions," *Chem. Eng. Sci.*, vol. 58, pp. 417 – 427, 2003.
- H. Ter Maat, J. A. Hogendoorn, and G. F. Versteeg, "The removal of hydrogen sulphide from gas stream using an aqueous metal sulphate

- absorbent. Part I. The absorption of hydrogen sulphide in metal sulphate solutions," *Sep. Purif. Technol.*, vol. 43, pp. 183 – 197, 2005.
- [3] M. Al-Tarazi, A. B. M. Heesink, and G. F. Versteeg, "Precipitation of metal sulphides using gaseous hydrogen sulphide: mathematical modelling," *Chem. Eng. Sci.*, vol. 59, pp. 567 – 579, 2004.
- [4] N. Karbanee, "Investigation towards controlled precipitation of nickel using H₂S gas by harnessing pH dependent sulphide speciation," M.Sc in Eng. Thesis, University of Cape Town, South Africa, 2007, unpublished.
- [5] V. Menard, and G. P. Demopoulos, "Gas transfer kinetics and redox potential consideration in oxidative precipitation of manganese from an industrial zinc sulphate solution with SO₂/O₂," *Hydrometallurgy*, vol. 89, pp. 357 – 368, 2007.
- [6] F. L. Bernardis, R. A. Grant, and D. C. Sherrington, "A review of methods of separation of the platinum-group metals through their chloro-complexes," *React. & Fun. Poly.*, vol. 65, pp. 205 – 217, 2005.
- [7] D. Dreisinger, W. Murray, D. Hunter, K. Baxter, J. Ferron and C. Fleming, "The Application of the PLATSOL™ Process to Copper-Nickel-Cobalt-PGE/PGM Concentrates from PolyMet Mining's NorthMet Deposit", Presented at ALTA 2005, Perth, WA, May, 2005, unpublished.
- [8] H. Kasaini, "Enrichment process for PGM-metals containing stream," South Africa Patent PCT/ZA2008/000067, July 28, 2008.
- [9] J. I. Kroschwitz and M. Howe-Grant, "Encyclopaedia of chemical technology, Kirk-Othmer 4th ed.," Wiley & Sons, New York, 1991.
- [10] K. K. Mishra and M. L. Kapoor, "Kinetics of liquid-gas reactions through bubbles," *Hydrometallurgy*, vol. 3, pp. 75-83, 1978.
- [11] R. Higbie, "The rate of absorption of a pure gas into a still liquid during short periods of exposure," *Trans. Am. Inst. Chem. Eng.*, Vol. 35, pp. 36-60, 1935.
- [12] C. Oktaybas, E. Acma, C. Arslan, and O. Addemir, "Kinetics of copper precipitation by H₂S from Sulphate solutions," *Hydrometallurgy*, vol. 35, pp. 129-37, 1994.
- [13] R. R. Broekhuis, D. J. Koch, and S. Lynn, "A medium temperature process for removal of hydrogen sulphide from sour gas streams with aqueous metal sulphate solutions," *Ind. Eng. Chem. Res.*, vol. 31 pp. 2635-42, 1992.
- [14] H. Maat Ter, J. A. Hogendoorn, and G. F. Versteeg, "The removal of hydrogen sulphide from gas stream using an aqueous metal sulphate absorbent: Part I The absorption of H₂O in metal sulphate solutions," *Separation and Purification Technology*, vol. 4, pp. 183 – 197, 2005
- [15] F. Habashi, "Principles of Extractive Metallurgy, Vol. 2" Gordon and Breach, Science Publishers, Inc. New York, pp. 203, 1970.
- [16] G. Schreier, and C. Edtmaier, "Separation of Ir, Pd, and Rh from secondary Pt scrap by precipitation and calcinations," *Hydrometallurgy*, vol. 68, pp. 69 – 75, 2003.
- [17] H. G. Julsing, and R. I. McCrindle, "The use of sodium formate for the recovery of precious metals from acidic base metal effluents," *Journal of Chem. Technol. & Biotechnology.*, vol. 76(4), pp. 349 - 354(6), 2001.
- [18] H. Kasaini, R. C. Everson, and O. S. L. Bruinsma, "Selective Adsorption of Platinum from Mixed solutions Containing Base Metals Using Chemically Modified Activated Carbons," *Separation Science and Technology*, vol. 40, pp. 507 – 523, 2005.
- [19] A. E. Nielsen, "Kinetics of nucleation," Pergamon Press Ltd.
- [20] O. Söhnel, and J. Garside, "Precipitation, basic principles and industrial Applications," Butterworth Heinemann Ltd., Oxford.
- [21] O. Levenspiel, "Chemical Reaction Engineering, 3rd ed.," John Wiley & Sons, Inc., New York, 1999, pp. 38 – 76.
- [22] Y. E. Kenig, U. Wiesner, and A. Gorak, "Modelling of reactive Absorption Using the Maxwell-Stefan Equations," *Ind. Eng. Chem. Res.*, vol. 36, pp. 4325 – 4334, 1997.
- [23] L. Rodriguez-Sevilla, M. Alvarez, G. Liminana, and M. C. Diaz, "Dilute SO₂ Absorption Equilibrium in Aqueous HCl and HCl Solution at 298.15 K," *J. Chem. Eng. Data*, vol. 47, pp. 1339 – 1345, 2002.
- [24] V. M. Dagaonkar, A. A. C. M. Beenackers, and V. G. Pangarkar, "Enhancement of gas-liquid mass transfer by small reactive particles at realistically high mass transfer coefficients: absorption of sulphur dioxide into aqueous slurries of Ca(OH)₂ and Mg(OH)₂ particles," *Chem. Eng. J.*, vol. 81, pp. 203 – 212, 2001.
- [25] H. Kasaini, M. Goto, and S. Furisaki, "Separation of Pd(II), Rh(III) and Ru(III) ions from a Mixed Chloride Solution Using Activated Carbon Pellets," *Sep. Sci. Technol.*, vol.35(9), pp. 1307 – 1327, 2000.
- [26] H. Kasaini, R. C. Everson, and O. S. L. Bruinsma, "Selective Adsorption of Platinum from mixed Solution Containing Base Metals using Chemically Modified Activated Carbons," *Sep. Sci. Technol.*, vol. 40, pp. 507 – 523, 2005.
- [27] M. Cox, "Solvent Extraction in Hydrometallurgy, Principles and Practices," In *Principles and Practices of Solvent Extraction*; J. Rydberg, C. Musikas, G. R. Choppin, Eds.; Marcel Dekker, Inc.: New York, pp. 381 – 393, 1992.
- [28] M. Cox, "Liquid-Liquid Extraction in Hydrometallurgy," In *Science and Practice of Liquid-Liquid Extraction*; Thornton, J. D., Ed.; Clarendon Press: Oxford 2, pp. 57, 1992.
- [29] A. Koliadima, J. Kaposos, and L. Farmakis, "Diffusion Coefficients of SO₂ in Water and Partition Coefficients of SO₂ in Water-Air Interface at Different Temperature and pH Values," *Instrument. Sci. And Technol.*, vol. 37, pp. 274 – 283, 2009.
- [30] D. G. Leait, "Diffusion Coefficient of Aqueous Sulphur Dioxide at 25°C," *J. Chem. Eng. Data*, vol. 29, pp. 281 – 282, 1984.
- [31] J. Boniface, Q. Shi, Y. Q. Li, J. L. Cheung, O. V. Rattigan, P. Davidovits, D. R. Worsnop, S. T. Jayne, and C. E. Kolb, " Uptake of gas-phase SO₂, H₂S and CO₂ by aqueous solutions," *J. Phys. Chem. A* vol. 104 (32), pp. 7502–7510, 2000.